

Installation Manual

Rotem
Trio
Controller



Rotem Trio

Poultry Controller

P/N: 116899



Rotem Trio Controller

Installation Manual

Rev 3.2, 04/2026

Software Ver: 9.1.10-2.0

This manual for use and maintenance is an integral part of the apparatus together with the attached technical documentation.

This document is destined for the user of the apparatus: it may not be reproduced in whole or in part, committed to computer memory as a file or delivered to third parties without the prior authorization of the assembler of the system.

Munters reserves the right to effect modifications to the apparatus in accordance with technical and legal developments.

Table of Contents

<i>Chapter</i>	<i>page</i>
1 INTRODUCTION	10
1.1 Disclaimer	10
1.2 Introduction	10
1.3 Notes	10
2 PRECAUTIONS	11
2.1 English	11
2.1.1 Infrastructure Protection and Backup	11
2.1.1.1 RPLP Power Line Protection	12
2.1.1.2 RIT-100 Isolated Transformer	12
2.1.1.3 TS-O2 Timer	12
2.1.1.4 Controller Backup	13
2.1.2 Protection Against Corrosion	13
2.1.3 Electrical Guidelines	13
2.1.4 Grounding Sensors	14
2.1.5 Reducing Interference	14
2.1.6 Filtering	14
2.1.7 Checking the CMOS RTC Batteries Level	15
2.1.7.1 Display Board Battery	15
2.1.7.2 Main Board Battery	15
2.1.8 Safety Precautions - Details	15
2.1.9 Grounding the Controller	16
2.1.9.1 Ground Rods	16
2.1.9.2 Ground Wire	16
2.1.9.3 Ground Clamps	17
2.1.9.4 What Should Be Grounded?	17
2.2 Français	17
2.2.1 Protection et Redondance de L'infrastructure	18
2.2.1.1 Protection de la Ligne D'alimentation RPLP	18
2.2.1.2 Transformateur D'isolement RIT-100	18
2.2.1.3 Temporisateur TS-O2	19
2.2.1.4 Contrôleur de Secours	19

2.2.2	Protection Contre la Corrosion.....	19
2.2.3	Directives Électriques.....	20
2.2.4	Raccord à la Terre (Sensores).....	20
2.2.5	Réduire les Interférences.....	20
2.2.6	Filtrage.....	20
2.2.7	Vérification du Niveau des piles CMOS RTC.....	21
2.2.7.1	Pile de la Carte D'affichage.....	21
2.2.7.2	Batterie de la Carte Mère.....	22
2.2.8	Précautions de Sécurité - Détails.....	22
2.2.9	Mise à la Terre du Contrôleur.....	22
2.2.9.1	Piquets de Prise de Terre.....	22
2.2.9.2	Fil de Garde.....	23
2.2.9.3	Colliers de Mise à la Terre.....	24
2.2.9.4	Quels Elements Doivent Etre Mis a la Terre?.....	24
2.3	Locking the Trio.....	24
2.4	Product Symbols.....	25
3	UNIT INSTALLATION.....	26
3.1	What Comes in the Package.....	27
3.1.1	Trio Controller.....	27
3.1.2	Expansion 70.....	27
3.2	Mounting the Units.....	27
3.2.1	Knockouts.....	27
3.2.2	Hanging the Rotem Trio Controller Unit.....	29
3.2.3	Hanging the Rotem Trio Expansion 70 Unit.....	29
3.3	Layouts.....	31
3.3.1	Rotem Trio Expansion Layout.....	31
3.3.2	Rotem Trio Controller Layout.....	33
3.4	Rotem Trio Expansion 70 Wiring Diagrams.....	36
3.4.1	Power.....	36
3.4.2	High Voltage Relays.....	37
3.4.3	Winch Card Wiring.....	38
3.4.4	Completing the Wiring.....	40
3.5	Rotem Trio Controller Wiring Diagrams.....	40
3.5.1	Alarms and Power.....	41
3.5.2	Internet Connection.....	42
3.5.3	Rotem Trio Expansion 70 – Rotem Trio Controller Communication.....	43
3.5.3.1	Cable Connection.....	43

3.5.3.2	RS-485 Wiring	44
3.5.3.3	Address.....	45
3.5.3.4	Restart.....	46
3.5.4	Board Wiring.....	46
3.5.4.1	Analog Output Devices	46
3.5.4.2	Digital Input Devices	47
3.5.4.3	Analog Input Devices.....	48
3.5.4.3.1	CO2 Sensor Wiring.....	48
3.5.4.3.2	Temperature Sensor Wiring	51
3.5.4.3.3	Humidity Sensor Wiring	53
3.5.4.3.4	Potentiometer Wiring	56
3.5.4.3.5	Ammonia Sensor Wiring.....	57
3.5.4.3.6	WOD Water Pressure Sensor Wiring	59
3.5.4.3.7	Light Sensor Wiring.....	60
3.5.5	Card Wiring.....	61
3.5.5.1	Digital Input Devices	61
3.5.5.2	Analog Input Devices.....	62
3.5.5.2.1	Analog Card DIP Switches	63
3.5.5.2.2	CO2 Sensor Wiring.....	64
3.5.5.2.3	Temperature Sensor Wiring	66
3.5.5.2.4	Humidity Sensor Wiring.....	68
3.5.5.2.5	Potentiometer Device Wiring.....	70
3.5.5.2.6	Ammonia Sensor Wiring.....	71
3.5.5.2.7	Light Sensor Wiring.....	72
3.5.5.3	Scale Card Devices	73
3.5.5.3.1	Bird Scale Wiring	73
3.5.5.3.2	Silo Wiring.....	74
3.5.6	Trio RPS.....	76
3.5.7	RSU Wiring.....	77
3.6	Termination.....	78
3.7	Pressure Sensor Hoses.....	78
3.8	Tech Support/Wi-Fi.....	79
4	SPECIFICATIONS.....	80
4.1	Rotem Trio Expansion 70 Specifications.....	80
4.2	Rotem Trio Controller Specifications.....	81
4.3	Electrical Notes.....	82
4.4	Devices Specifications.....	82
5	USING THE TRIO TOUCH SCREEN.....	85
6	MAPPING AND DEFINING THE INPUT OUTPUT DEVICES.....	87

6.1	Understanding the Devices and Sensors Screen	87
6.2	Using the Mapping Screen	90
6.3	Editing Relays and Sensors	94
6.4	Defining Sensors	94
6.4.1	Defining Analog Sensors	94
6.4.1.1	Enabling/Disabling Analog Input Sensors	94
6.4.1.2	Temperature Sensors	95
6.4.1.2.1	Defining the Temperature Sensors	95
6.4.1.2.2	Mapping the Temperature Sensors to Devices	95
6.4.1.2.3	Enabling a Weather Station	96
6.4.1.3	Defining the Ammonia Sensor	97
6.4.1.4	Defining the CO2 Sensor	97
6.4.1.5	Defining the Humidity Sensors	98
6.4.1.6	Defining the Light Sensor	98
6.4.2	Defining Digital Sensors	99
6.4.2.1	Defining the Water Meter Sensors	99
6.4.2.2	Defining the Gas Meter Sensors	100
6.4.2.3	Defining the Power Meter Sensors	100
6.4.2.4	Defining the Auger Active Sensors	101
6.4.2.5	Defining the Feeder Active Sensors	101
6.4.2.6	Defining the Auxiliary Input	102
6.5	Defining Devices	102
6.5.1	Introduction to Device Definition	103
6.5.1.1	Current Sense Relays	103
6.5.1.1.1	Set Up	103
6.5.1.1.2	Monitoring and Alarms	104
6.5.1.2	Defining 0 – 10V Analog Output Ports	104
6.5.2	Defining the Fans	104
6.5.2.1	On-Off Fans	105
6.5.2.2	0 – 10 Volt Fans	105
6.5.3	Defining the Stir Fan	106
6.5.3.1	On Off Stir Fan	106
6.5.3.2	0 – 10 Volt Stir Fan	106
6.5.4	Defining the Blowback Fan	107
6.5.5	Defining Heating Devices	108
6.5.5.1	Defining the On/Off Heaters	108
6.5.5.2	Defining the Variable Heaters	108
6.5.5.3	Defining the High Heaters	109
6.5.6	Defining the Cooling Pads	109

6.5.7	Defining the Foggers.....	110
6.5.8	Mapping the Potentiometers, Inlets, Tunnel Doors, Outlets.....	111
6.5.8.1	Mapping the Potentiometers.....	111
6.5.8.2	Defining the Inlets/Tunnel Doors.....	112
6.5.8.2.1	Potentiometer Calibration.....	112
6.5.8.2.2	Calibrating the Inlets/Tunnel Door.....	113
6.5.8.3	Defining the Outlet.....	115
6.5.9	Defining the Same As Relays.....	116
6.5.10	Defining the Same As Analog Ports.....	116
6.5.11	Defining the Timers.....	117
6.5.12	Lighting Devices.....	118
6.5.12.1	Defining the On/Off LIGHTS.....	118
6.5.12.2	Defining the Variable Lights.....	118
6.5.13	Feeding Devices.....	119
6.5.13.1	Defining the Auger Relays.....	119
6.5.13.2	Defining the Feeder Relays.....	120
6.5.14	Fail Safe Devices.....	120
6.5.15	Water Pressure Devices.....	121
6.5.15.1	Defining the WOD.....	121
6.5.15.2	Defining the WOD Pro.....	121
6.5.15.3	WOD Pro Calibration.....	122
6.6	Mapping the Weighing Devices.....	124
6.6.1	Defining the Silos.....	124
6.6.1.1	Mapping the Silo Scales.....	124
6.6.1.2	Configuring the Silo Scale.....	124
6.6.1.3	Testing the Silo.....	128
6.6.2	Defining BinTrac Silos.....	129
6.6.3	Defining the Bird Scales.....	131
6.6.3.1	Mapping the Bird Scales.....	131
6.6.3.2	Calibrating the Bird Scales.....	132
6.6.3.3	Testing the Bird Scale.....	134
6.6.4	Defining the RSU.....	135
6.7	Defining the Trio RPS.....	135
6.7.1	Define the Sensor.....	135
6.7.2	Static Pressure Calibration.....	136
6.8	Testing Devices.....	138
7	SWITCHES.....	140
7.1	Relay Types.....	140

7.2	Moving the Toggle Switch	141
7.3	Viewing the Relays' Status	142
8	APPENDIX A: ALARM BACKUP BATTERY	143
8.1	General Description	143
8.2	Detailed Description	145
8.3	Preparing the Battery for Operation After Transportation or Storage	147
9	APPENDIX B: SERVICE MANUAL	148
9.1	Maintenance	148
9.2	Trouble Shooting	149
9.2.1	Internet	149
9.2.2	Electronic Components	150
9.3	Spare Parts	151
9.3.1	Preliminary Information	152
9.3.2	Rotem Trio Minimal Spare Parts	152
9.3.3	Rotem Trio Controller	153
9.3.3.1	Rotem Trio Controller Container Spare Parts	154
9.3.3.2	Rotem Trio Controller Door Card Spare Parts	156
9.3.3.3	Rotem Trio Controller Main Container Spare Parts	158
9.3.4	Rotem Trio Expansion 70	161
9.3.4.1	Rotem Trio Expansion 70 Container Spare Parts	162
9.3.4.2	Rotem Trio Expansion 70 Cards Spare Parts	164
9.3.4.3	Rotem Trio Expansion 70 Main Container Cards Spare Parts	166
9.3.5	Additional Options	167
9.3.6	Cards	168
9.3.6.1	Rotem Trio Controller Cards & Accessories	168
9.3.6.1.1	Door Cards	169
9.3.6.1.2	Main Container Cards	171
9.3.6.1.3	Cables and Harnesses	174
9.3.6.2	Rotem Trio Expansion 70 Cards and Accessories	174
9.3.6.2.1	Door Cards	175
9.3.6.2.2	Main Container Cards	175
9.3.6.2.3	Cables and Harnesses	177
10	APPENDIX C: TRIO CELL MODEM INSTALLATION	178
10.1	Prerequisites	178
10.1.1	Supported Devices	178
10.1.2	Required Software	178

10.1.3	Internet Access.....	179
10.2	Installation.....	179
10.2.1	Physical Installation.....	179
10.2.1.1	Modem and SIM Card.....	179
10.2.1.2	Drilling.....	183
10.2.2	Configuration.....	184
11	APPENDIX D: IT SETUP.....	187
11.1	IT Setup.....	187
11.2	Subnet Setup.....	188
11.2.1	Required Equipment.....	188
11.2.2	Procedure.....	188
11.3	LAN Cable Information.....	189
11.3.1	Wire/Optical Ethernet Infrastructure Basics.....	189
11.3.2	Trio Connectivity: 100/1000 GBPS Ethernet Switch.....	189
11.4	Typical Setups.....	190
12	WARRANTY.....	192

1 Introduction

1.1 Disclaimer

Munters reserves the right to make alterations to specifications, quantities, dimensions etc. for production or other reasons, subsequent to publication. The information contained herein has been prepared by qualified experts within Munters. While we believe the information is accurate and complete, we make no warranty or representation for any particular purposes. The information is offered in good faith and with the understanding that any use of the units or accessories in breach of the directions and warnings in this document is at the sole discretion and risk of the user.

1.2 Introduction

Congratulations on your excellent choice of purchasing a Rotem Trio Controller and Rotem Trio Expansion 70!

In order to realize the full benefit from this product it is important that it is installed, commissioned and operated correctly. Before installation or using the controller, this manual should be studied carefully. It is also recommended that it is kept safely for future reference. The manual is intended as a reference for installation, commissioning and day-to-day operation of the Munters Controllers.

1.3 Notes

Date of release: Jan 2020

Munters cannot guarantee to inform users about the changes or to distribute new manuals to them.

All rights reserved. No part of this manual may be reproduced in any manner whatsoever without the expressed written permission of Munters. The contents of this manual are subject to change without notice.

2 Precautions

- English
- Français
- Locking the Trio
- Product Symbols

2.1 English

CAUTION *Protection provided by the equipment can be impaired if the equipment is used in a manner not specified by the manufacturer!*

CAUTION *There is a risk of explosion if the lithium battery is replaced with an incorrect type. Replace the battery using the same type and manufacturer only.*

- Infrastructure Protection and Backup
- Protection Against Corrosion
- Electrical Guidelines
- Grounding Sensors
- Reducing Interference
- Filtering
- Checking the CMOS RTC Batteries Level
- Safety Precautions - Details
- Grounding the Controller

2.1.1 INFRASTRUCTURE PROTECTION AND BACKUP

Electrical grid disturbances—including voltage spikes, transient power drops, line fluctuations, and instability—may result in physical damage to controllers if not adequately mitigated.

To prevent controller damage, in areas having known, repeated issues with electrical supply stability Munters requires installing a protection infrastructure consisting of the Munters RPLP, Munters RIT-100, and a Trumeter TS-02 timer. Installing these products are best industrial practice.

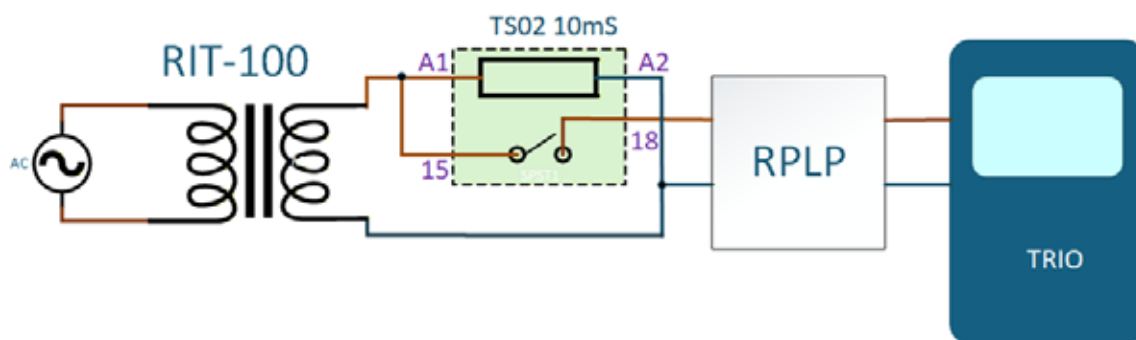

Figure 1: Electrical Protection Setup

- RPLP Power Line Protection
- RIT-100 Isolated Transformer
- TS-O2 Timer
- Controller Backup

2.1.1.1 RPLP Power Line Protection

Install an RPLP-1 to provide lightning protection to the controllers as well as reducing noise. While no lightning protection is perfect, the RPLP-1 significantly enhances the reliability of built-in lightning protection. Refer to the RPLP-1 documentation for detailed wiring instructions and specifications.

NOTE Common surge protectors provide little additional protection and may trip unnecessarily.

- RPLP-1-V1 (115 Volt): P/N: 922-01-00001
- RPLP-1-V2 (230 Volt): P/N: 922-01-00002

2.1.1.2 RIT-100 Isolated Transformer

Electronic controllers can be damaged by disturbances in the power supply. Examples of disturbances include:

- Lightning strikes
- Power line spikes

Munters RIT-100 stabilizes incoming power, preventing spikes (very short (microseconds to milliseconds), sharp changes (positive or negative) in voltage). In addition, RIT-100 defends the controller against power surges or lightning strikes that run through a power line. Refer to the RIT-100 documentation for detailed wiring instructions and specifications.

- P/N: 922-02-00006 (RIT100-POU-230V-TO-230V-100VA or 115V-TO-115V-50VA)

2.1.1.3 TS-O2 Timer

The Trumeter TS-O2 timer blocks electrical input when the voltage drops below 120 VAC. After a delay of 10 seconds, the TS-O2 reconnects the electrical system once the voltage rises above 150 VAC.

- P/N: TS02 – 240V AC / 24V AC/DC, ON-Delay, 1 C/O

2.1.1.4 Controller Backup

Munters strongly recommends that all controllers have a backup controller that operates during a primary controller failure or during extreme temperatures. The backup ensures animal survival in cases of extreme temperatures or power disruptions. The backup controller comes into play when:

- A general controller failure occurs, in this case the controller functions at the current operating temperature.
- House temperatures readings are higher than what is set for the thermostat.

In both situations, the backup controller sends out alarms and/or takes over basic operations.

Munters provides two different backup systems:

- USA/Canada: [RBU-27](#) and [RDT-5](#) (Double Phase)
- EMEA/Asia: [RBU-5](#) (Triple Phase)

2.1.2 PROTECTION AGAINST CORROSION

To prevent against corrosion of electrical components:

- Installation location: If possible, install the Trio in a well-ventilated area.
- Keep the Trio closed at all times when a litter or passel is present in the building. In situations where maintenance or repairs are required, close the controller when you finish the work.
- After running the cables through the knockouts, seal the holes with a silicon sealant. If you use silicon sealant with acetic acid cure, keep the controller open and ventilated until cured. Otherwise, the acetic acid will attack metal components, including circuitry.
- When splicing sensors to longer wires, ensure that the splice is waterproof. Use adhesive lined heat shrink (marine grade) to make waterproof connections.
- Use shielded wiring for low level signals. For buried wiring (building to building runs) use high grade jell filled cables that are impervious to moisture.

2.1.3 ELECTRICAL GUIDELINES

- If this unit is installed in an electrical closet, ensure that no contactors are in that closet. Placing this unit in proximity (50 centimeters/1.5 feet or less) to contactors results in severe signal interference.
- Review the guidelines given in the Precautions and Safety Precautions sections. These are vital to ensuring both personal safety and proper controller functioning.

2.1.4 GROUNDING SENSORS

- Every low power device (digital, analog, or communication) must have a shield cable connected to the unit ground strip.

2.1.5 REDUCING INTERFERENCE

- Avoid mixing high voltage wiring with sensor and low voltage wiring. There should be at least 3 feet/1 meter between sensor and electrical cables.
- Keep the controller as far as possible from heavy contactor boxes and other sources of electrical interference.
- Do not connect communication wire shields, which go from one house to another at both ends. Connect them at one end only. Connection at both ends can cause ground loop currents to flow, which reduce reliability.
- The communication COM wiring is not the shield wire! The COM, RX and TX wires must connect to each other at all controllers.
- Refer to Safety Precautions - Details, page 15 for more information.

2.1.6 FILTERING

If this installation includes a power inverter to drive variable speed fans, install an EMI filter in front of the inverter, according to the specifications provided by the inverter manufacturer. Refer to the inverter documentation.

Frequency inverters can cause severe electrical and electromagnetic interference. Therefore, when employing a frequency inverter, it is critical that you carefully follow the manufacturer's installation instructions.

In particular verify:

- That the cable shielding between the inverter and any motor meets industry standards
- Proper grounding of the inverter's chassis and motor power cable
- Proper grounding of low voltage cable shield wire
- That the controller and inverter cables are kept in separate conduits or wire bundles

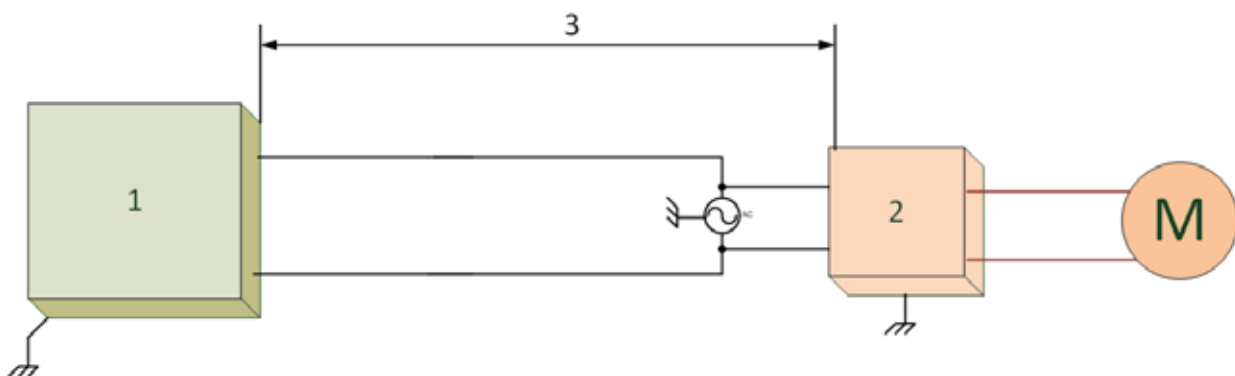

Figure 2: Inverter Setup

1. Controller

2. Inverter
3. Place the controller at least 1.5 feet/50 centimeters from the inverter.

2.1.7 CHECKING THE CMOS RTC BATTERIES LEVEL

- Display Board Battery
- Main Board Battery

2.1.7.1 Display Board Battery

On the Trio Controller Display Board (refer to Figure 14) is a CMOS Battery. This CMOS battery keeps the CPU's real-time clock running when the power is off.

Check the battery once a year. The output must be 2.7 volts (minimum). Authorized personnel only must replace the battery if the output is below the minimum required level or every five years. Use a RENATA-CR2450N battery only.

If the CMOS battery output is below the required minimum, an icon  appears on the touch screen and on the TrioAir app.

CAUTION *If the CMOS battery output is below the required minimum, in the event of a power failure the user will have to reset the time and date when power is reapplied.*

2.1.7.2 Main Board Battery

On the Trio Controller Main Board is a CMOS Battery. This battery is located behind the Scale Card (refer to Figure 15). This CMOS battery keeps the board's real-time clock running when the power is off.

Do not test this battery. If the CMOS battery output is below the required minimum, Trio sends an alarm to everyone on the contact list. In this event, an authorized technician must replace the battery with a RENATA-CR2450N battery only.

CAUTION *If the CMOS battery output is below the required minimum, in the event of a power failure the user will have to reset the time and date when power is reapplied.*

Warning: It is very important to reset the growth date to the required day.

2.1.8 SAFETY PRECAUTIONS - DETAILS

CAUTION *An authorized electrician must install these units. Disconnect the power to avoid electrical shock and damage.*

NOTE *Installation Category (Over voltage Category) II*

- The power supply to the controller should be protected by a 10 amp circuit breaker.
- All electrical connections should comply with National Electrical code (NEC).

2.1.9 GROUNDING THE CONTROLLER

- Ground Rods
- Ground Wire
- Ground Clamps
- What Should Be Grounded?

2.1.9.1 Ground Rods

Ground rods are used to efficiently connect the system to earth where current may be dissipated in the soil.

1. Material: Ground rods should be copper clad or galvanized steel.
2. Diameter: Minimum 5/8", preferably 3/4". Generally the larger the rod diameter, the lower it's resistance to current flow.
3. Length: Minimum 2.5 meters (8 feet), preferably 3-meter (10-foot). A longer ground rod will reach a soil with higher moisture content. Moist soil carries current much better than drier soil.
4. Single grounding: It is important that there is only one grounding location where a rod or series of rods are connected to each other using a ground wire.
5. Independent ground rods will increase the risk of current, from a lightning strike for example, being dissipated through one rod and reentering the system through an adjacent rod.
6. Location: Close to the main circuit breaker panel and in moist soil. For example in an area that is usually wet from a drip or a low spot where water drains. Make sure the area is well protected from damage by lawnmowers, tractors, etc.'.
7. Rod installation: Drive the rod into the earth until about 10 cm (4 inches) is left above grade. If it is impossible to drive the rod to the proper depth, it is acceptable to lay the rod horizontally, 80 cm (2.5 feet) below grade.
8. In case the rod is exposed to damage, for example by lawnmowers or tractors it can be installed in a hole, about 20 cm (8 inches) deep so that the rod is about 10 cm under grade and 10 cm above hole level.

NOTE The National Electric Code (NEC) mandates two ground rods unless you can show less than 10 ohms resistance with one rod.

2.1.9.2 Ground Wire

The ground wire is a large copper wire that connects the main circuit breaker panel to the ground rod.

1. Material: Ground rods should be copper clad or galvanized steel.
2. Diameter: Typically, 16 mm (6-gauge) copper wire is sufficient. If the wire run is greater than 20 feet, 20 mm (4-gauge) wire should be used.

3. Length: Minimum 2.5 meters (8 feet), preferably 3-meter (10-foot). A longer ground rod will reach a soil with higher moisture content. Moist soil carries current much better than drier soil.

4. The ground wire should be protected from damage by lawnmowers, tractors, etc. It should be buried at a minimum of 15 cm (6 inches) under grade for protection and enter the house as soon as possible. It is important that the wire not be cut; it should remain continuous.

2.1.9.3 Ground Clamps

Ground wires should not be merely wrapped around a ground rod. Ground clamps are used to attach a ground wire to a ground rod. The most common clamp is known as an acorn clamp. Make sure the ground clamps you select are rated for outdoor use. Do not use pipe clamps rated for inside water lines or hose clamps to attach the ground wire.

2.1.9.4 What Should Be Grounded?

Any equipment that is or could become energized, even accidentally, should be grounded. Current from lightning, strikes objects in a random fashion. Accounts of lightning strikes reveal scenarios most of us could not predict.

Electric circuits should be wired with a 3-wire conductor consisting of hot, neutral, and grounding wires. The grounding wire should be attached cleanly and securely to devices or systems to be grounded. The other end of the grounding wire should be attached to the ground bus on the main panel.

2.2 Français

- Protection de L'infrastructure et Système de Secours
- Protection Contre la Corrosion
- Directives Électriques
- Raccord à la Terre (Sensores)
- Réduire les Interférences
- Filtrage
- Vérification du Niveau des piles CMOS RTC
- Précautions de Sécurité - Détails
- Mise à la Terre du Contrôleur

CAUTION *La protection fournie par l'équipement peut être compromise si l'équipement est utilisé d'une façon non spécifiée par le fabricant !*

CAUTION *Il existe un risque d'explosion si la batterie au lithium est remplacée par un type incorrect. Remplacez la batterie uniquement par une batterie du même type et du même fabricant.*

2.2.1 PROTECTION ET REDONDANCE DE L'INFRASTRUCTURE

Les perturbations du réseau électrique – y compris les surtensions, les chutes transitoires de tension, les fluctuations de ligne et l'instabilité – peuvent provoquer des dommages physiques aux contrôleurs si elles ne sont pas correctement atténuées.

Pour prévenir les dommages aux contrôleurs, dans les zones où la stabilité de l'alimentation électrique est connue pour poser des problèmes récurrents, Munters exige l'installation d'une infrastructure de protection composée du Munters RPLP, du Munters RIT-100 et d'un temporisateur Trumeter TS-02. L'installation de ces produits constitue une bonne pratique industrielle.

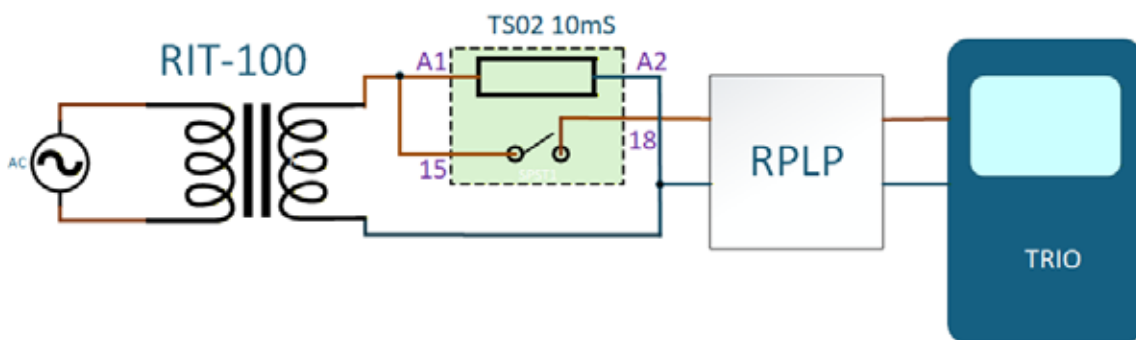

Illustration 3: Configuration de la protection électrique

- Protection de la Ligne D'alimentation RPLP
- Transformateur D'isolement RIT-100
- Temporisateur TS-02
- Contrôleur de Secours

2.2.1.1 Protection de la Ligne D'alimentation RPLP

Installez un RPLP-1 pour assurer une protection contre la foudre des contrôleurs ainsi que pour réduire les parasites. Bien qu'aucune protection contre la foudre ne soit parfaite, le RPLP-1 améliore considérablement la fiabilité de la protection intégrée. Reportez-vous à la documentation du RPLP-1 pour les instructions de câblage détaillées et les spécifications.

REMARQUE Les parasurtenseurs courants offrent peu de protection supplémentaire et peuvent se déclencher inutilement.

- RPLP-1-V1 (115 V): P/N: 922-01-00001
- RPLP-1-V2 (230 V): P/N: 922-01-00002

2.2.1.2 Transformateur D'isolement RIT-100

Les contrôleurs électroniques peuvent être endommagés par des perturbations de l'alimentation électrique. Exemples de perturbations:

- Impacts de foudre
- Pics de tension sur la ligne d'alimentation

Le Munters RIT-100 stabilise l'alimentation entrante, en empêchant les pics (variations très brèves – microsecondes à millisecondes – et abruptes, positives ou négatives, de la tension). En outre, le RIT-100 protège le contrôleur contre les surtensions ou les impacts de foudre se propageant via la ligne d'alimentation. Reportez-vous à la documentation du RIT-100 pour les instructions de câblage détaillées et les spécifications.

- P/N: 922-02-00006 (RIT100-POU-230V-TO-230V-100VA ou 115V-TO-115V-50VA)

2.2.1.3 Temporisateur TS-02

Le temporisateur Trumeter TS-02 bloque l'entrée électrique lorsque la tension chute en dessous de 120 VAC. Après un délai de 10 secondes, le TS-02 rétablit l'alimentation une fois la tension remontée au-dessus de 150 VAC.

- P/N: TS02 – 240 V AC / 24 V AC/DC, retard à l'enclenchement (ON-Delay), 1 contact inverseur (1 C/O)

2.2.1.4 Contrôleur de Secours

Munters recommande fortement que tous les contrôleurs disposent d'un contrôleur de secours qui prene le relais en cas de défaillance du contrôleur principal ou de températures extrêmes. Le système de secours garantit la survie des porcs en cas de températures extrêmes ou de perturbations de l'alimentation électrique. Le contrôleur de secours intervient lorsque:

- Une défaillance générale du contrôleur se produit ; dans ce cas, le contrôleur fonctionne à la température de fonctionnement actuelle.
- Les relevés de température du bâtiment sont supérieurs à la consigne du thermostat.

Dans les deux cas, le contrôleur de secours émet des alarmes et/ou prend en charge les opérations de base.

Munters propose deux systèmes de secours différents:

- USA/Canada: RBU-27 et RDT-5
- EMEA/Asie: RBU-5

2.2.2 PROTECTION CONTRE LA CORROSION

Pour éviter la corrosion des composants électriques:

- Installez les commandes électroniques dans une salle de commande ventilée séparée, à l'abri des températures extrêmes et des environnements sales. Placer les commandes de façon à ce que les opérateurs puissent facilement les utiliser et lire les indicateurs et les affichages.
- Gardez le contrôleur fermé à tout moment lorsqu'il y a de la poubelle ou un passage dans le bâtiment. Dans les situations nécessitant une maintenance ou des réparations, fermez le contrôleur lorsque vous avez terminé le travail.

- Après avoir acheminé les câbles à travers les ouvertures, scellez les trous avec un produit d'étanchéité au silicone. Si vous utilisez un mastic de silicone avec durcissement à l'acide acétique, maintenez le contrôleur ouvert et ventilé jusqu'à ce qu'il durcisse. Sinon, l'acide acétique attaquera les composants métalliques, y compris les circuits.
- Lors du raccordement de capteurs à des câbles plus longs, assurez-vous que le raccordement est étanche. Utilisez une gaine thermorétractable adhésive (qualité marine) pour réaliser des connexions étanches.
- Utilisez un câblage blindé pour les signaux de faible niveau. Pour les câbles enterrés (d'un bâtiment à l'autre), utilisez des câbles remplis de gel de haute qualité, imperméables à l'humidité.

2.2.3 DIRECTIVES ÉLECTRIQUES

- Munters recommande vivement que seuls les contrôleurs montés sur panneau soient installés directement dans une armoire électrique.
- Placer cette unité à proximité (50 centimètres/1,5 pieds maximum) de tout appareil électrique transmettant 10 ampères ou plus de courant peut entraîner de graves interférences de signal.
- Consulter les consignes données dans Précautions de Sécurité - Détails, page XX pour plus de détails. Elles sont essentielles pour garantir à la fois la sécurité personnelle et le bon fonctionnement du contrôleur.

2.2.4 RACCORD À LA TERRE (SENSEURS)

- Chaque appareil à faible puissance (numérique, analogique ou de communication) doit être équipé d'un câble blindé raccordé à la barrette de mise à la terre de l'unité.

2.2.5 RÉDUIRE LES INTERFÉRENCES

- Maintenez les câbles basse tension séparés des câbles haute tension. Il doit y avoir au moins un mètre entre le capteur et les câbles électriques.
- Maintenez le contrôleur aussi loin que possible du boîtier lourd de contacteur et des autres sources d'interférences électriques.
- Ne connectez les protections des fils de communication, allant d'une maison à une autre aux deux extrémités. Connectez-les à une seule extrémité uniquement. La connexion aux deux extrémités peut entraîner la circulation de courants dans la boucle de terre, et risquer ainsi de réduire la fiabilité.
- La connexion COM pour les communications n'est pas le fil blindé. Les fils COM, RX et TX doivent être connectés les uns aux autres au niveau de tous les contrôleurs.

2.2.6 FILTRAGE

Si cette installation comprend un onduleur pour entraîner des ventilateurs à vitesse variable, RLD, RVS-2 ou tout autre dispositif qui commute un courant électrique

élevé, installez un filtre EMI devant l'appareil. Reportez-vous à la documentation de l'appareil.

- Que le blindage du câble entre l'appareil et tout moteur est conforme aux normes industrielles
- Mise à la terre correcte du châssis de l'appareil et du câble d'alimentation du moteur
- Mise à la terre correcte du fil blindé du câble basse tension
- Que les câbles du contrôleur et de l'appareil sont conservés dans des conduits ou faisceaux de câbles séparés

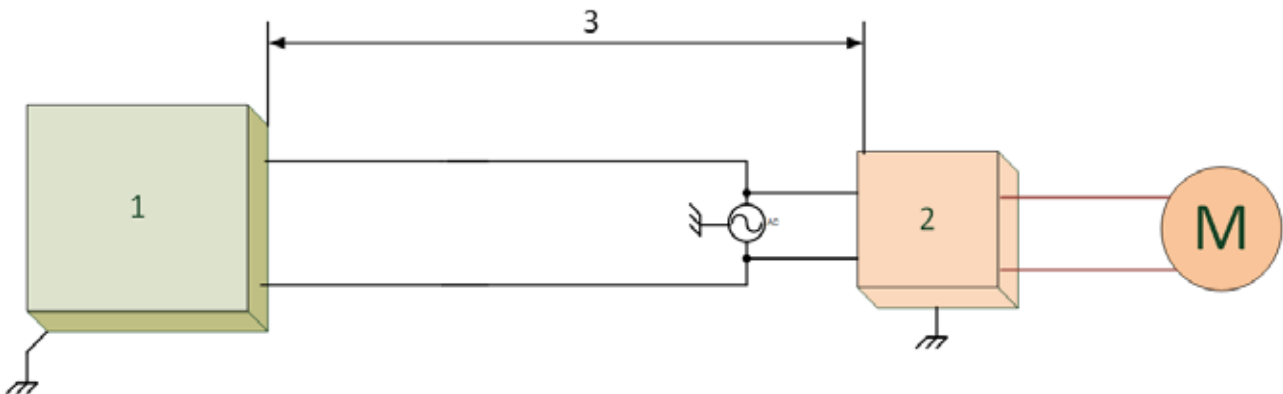

Illustration 4: Emplacement de l'onduleur

1. Contrôleur
2. Dispositif de courant électrique élevé
3. Placez le contrôleur à au moins 50 centimètres de l'appareil

2.2.7 VÉRIFICATION DU NIVEAU DES PILES CMOS RTC

- Pile de la Carte D'affichage
- Batterie de la Carte Mère

2.2.7.1 Pile de la Carte D'affichage

La carte d'affichage Trio (voir Utilisation de l'écran tactile Trio) est équipée d'une pile CMOS. Cette pile CMOS permet à l'horloge temps réel du processeur de continuer à fonctionner lorsque l'appareil est hors tension.

Vérifiez la batterie une fois par an. La tension doit être de 2,7 volts (minimum). Seul le personnel autorisé doit remplacer la batterie si la tension est inférieure au niveau minimum requis ou tous les cinq ans. Utilisez uniquement une batterie RENATA-CR2450N.

Si la tension de la batterie CMOS est inférieure au minimum requis, une icône  apparaît sur l'écran tactile et dans l'application TrioAir.

CAUTION ATTENTION *Si la tension de la batterie CMOS est inférieure au minimum requis, en cas de panne de courant, l'utilisateur devra réinitialiser l'heure et la date lorsque le courant sera rétabli.*

2.2.7.2 Batterie de la Carte Mère

La carte mère Trio est équipée d'une batterie CMOS. Cette batterie est située derrière la carte de pesée (voir figure 7). Cette batterie CMOS permet à l'horloge en temps réel de la carte de continuer à fonctionner lorsque l'appareil est hors tension.

Ne testez pas cette batterie. Si la sortie de la batterie CMOS est inférieure au minimum requis, Trio envoie une alarme à toutes les personnes figurant sur la liste de contacts. Dans ce cas, un technicien agréé doit remplacer la batterie par une batterie RENATA-CR2450N uniquement.

CAUTION ATTENTION *Si la tension de la batterie CMOS est inférieure au minimum requis, en cas de panne de courant, l'utilisateur devra réinitialiser l'heure et la date lorsque le courant sera rétabli.*

WARNING! *Avertissement: il est très important de réinitialiser la date de croissance au jour requis.*

2.2.8 PRÉCAUTIONS DE SÉCURITÉ - DÉTAILS

NOTE *Catégorie d'installation (catégorie de surtension) II*

- L'alimentation électrique du contrôleur doit être protégée par un disjoncteur de 10 A.
- Tous les raccordements électriques doivent être conformes au National Electrical Code (NEC)

2.2.9 MISE À LA TERRE DU CONTRÔLEUR

- Piquets de Prise de Terre
- Fil de Garde
- Colliers de Mise à la Terre
- Quels Elements Doivent Etre Mis a la Terre?

2.2.9.1 Piquets de Prise de Terre

Les piquets de prise de terre sont utilisés pour connecter efficacement le système à la terre, lorsque le courant peut être dissipé dans le sol.

1. Matériel: Les piquets de prise de terre doivent être plaqués cuivre ou en acier galvanisé.
2. Diamètre: Minimum 12,5/20,3 cm, de préférence 7,6/10,16 cm.
Généralement, plus le diamètre du piquet est gros, moindre sera sa résistance à la circulation du courant.

3. Longueur: Au minimum 2,5 mètres, de préférence 3 mètres. Un piquet de prise de terre plus long atteindra un sol avec une humidité plus élevée. Des sols humides portent beaucoup mieux le courant que des sols plus secs.
4. Mise à la terre unique: Il est essentiel qu'il n'y ait qu'un seul emplacement de mise à la terre auquel un piquet ou une série de piquets sont connectés les uns aux autres à l'aide d'un fil de garde.
5. Des piquets de prise de terre indépendants augmenteraient le risque de courant, provenant par exemple d'un éclair, dissipé par un piquet et réintégrant le système par un piquet adjacent.
6. Emplacement: Prêt du panneau de panneau du disjoncteur principal et dans un sol humide. Par exemple, dans une zone qui est habituellement humide provenant de précipitation, ou un point bas où l'eau est drainée. Assurez-vous que la zone est bien protégée des dommages pouvant être causés par des tondeuses à gazon, des tracteurs, etc.
7. Installation du piquet: Enfoncez le piquet dans le sol jusqu'à ce qu'il reste 10 cm au dessus du niveau du sol. S'il est impossible d'enfoncer le piquet à une profondeur correcte, vous pouvez poser le piquet horizontalement, 80 cm en dessous du niveau du sol.
8. Dans le cas où le piquet risque d'être endommagé, par exemple, par des tondeuses à gazon ou des tracteurs, il peut être installé dans un trou, à une profondeur d'environ 20 cm pour que le piquet soit environ 10 cm en dessous du niveau du sol et 10 cm au dessus du niveau du trou.

NOTE Le National Electric Code (NEC) a comme impératif l'utilisation de deux piquets de prise de terre, à moins que vous puissiez montrer que la résistance est inférieure à 10 ohms avec un piquet.

2.2.9.2 Fil de Garde

Le fil de garde est un fil cuivré long et épais qui connecte le panneau du disjoncteur principal au piquet de prise de terre.

1. Matériel: Les piquets de prise de terre doivent être plaqués cuivre ou en acier galvanisé.
2. Diamètre: Généralement un fil cuivré de 16 mm (de calibre no. 6) suffit. Si le fil doit parcourir plus de 7m, un fil de 20 mm (de calibre no.4) devrait être utilisé.
3. Longueur: Au minimum 2,5 mètre, de préférence 3 mètres. Un piquet de prise de terre plus long atteindra un sol avec une humidité plus élevée. Des sols humides portent beaucoup mieux le courant que des sols plus secs.
4. Le fil de garde devrait être protégé des dommages pouvant être provoqués par des tondeuses à gazon, des tracteurs, etc. Il devrait être enterré au moins à 15 cm sous le sol pour protection, et être inséré dans la maison aussi vite que possible. Il est important que le fil ne soit pas coupé, il devrait rester entier.

2.2.9.3 Colliers de Mise à la Terre

Des fils de gardes ne devraient pas simplement revêtir un piquet de prise de terre. Des colliers de mise à terre sont utilisés pour attacher un fil de garde au piquet de prise de terre. Le collier le plus ordinaire est un collier ocre. Assurez-vous que les colliers de mise à terre que vous sélectionnez sont adaptés à une utilisation à l'extérieur. N'utilisez pas de collier de serrage adapté pour des conduites d'eau intérieures ou colliers de serrage pour tuyaux flexibles pour rattacher le fil de garde.

2.2.9.4 Quels Elements Doivent Etre Mis a la Terre?

Tout équipement qui est ou pourrait être sous tension, même accidentellement, devrait être mis à la terre. Les objets qui pourraient être aléatoirement porteurs de la foudre y sont inclus. Des récits de foudre ont montré des cas imprévisibles.

Les circuits électriques devraient être câblés avec un conducteur à 3 fils, constitué d'un fil de garde, d'un fil conducteur neutre et d'un fil chaud. Le fil de garde devrait être rattaché nettement et sûrement aux dispositifs ou aux systèmes à mettre à la terre. L'autre extrémité du fil de garde devrait être rattachée au collecteur de terre sur le panneau principal.

2.3 Locking the Trio

Ensure that the units remain locked to prevent unauthorized access to internal components.

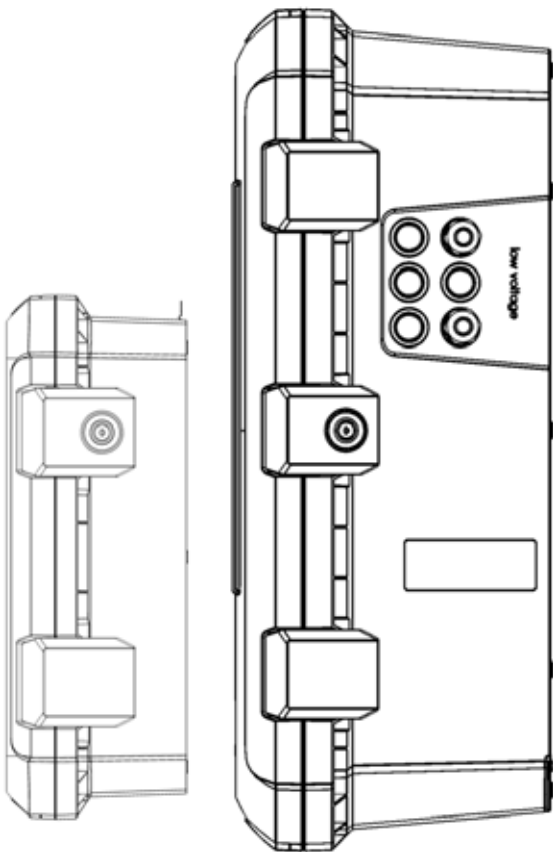

Figure 5: Trio Locks

2.4 Product Symbols

The following labels appear on your controller:



: Caution! Hazardous voltage



: Caution: Refer to the manual



: Main Protective Earthing Terminal

CAUTION *IF THE UNIT IS USED IN A MANNER NOT SPECIFIED BY THE MANUFACTURER, THE PROTECTION PROVIDED BY THE EQUIPMENT MAY BE IMPAIRED.*

3 Unit Installation

The following sections detail how to mount and wire the Rotem Trio Controller and Rotem Trio Expansion 70.



Figure 6: Rotem Trio Expansion 70



Figure 7: Rotem Trio Controller

NOTE Munters recommends that a trained technician perform the following operations.

- What Comes in the Package
- Mounting the Units
- Layouts
- Rotem Trio Expansion 70 Wiring Diagrams
- Rotem Trio Controller Wiring Diagrams
- Termination
- Pressure Sensor Hoses
- Tech Support/Wi-Fi

3.1 What Comes in the Package

In all standard orders, additional components are shipped with Trio Controller and Trio Expansion 70.

- Trio Controller
- Expansion 70

3.1.1 TRIO CONTROLLER

- Trio metal bracket
- Six RTS sensors
- Air pressure hoses
- Four screws (used for mounting the controller)
- Lock key (two copies)
- Quick Guide

3.1.2 EXPANSION 70

- Six long screws
- Six short screws
- Mounting brackets
- Relay labels
- Communication cable
- Lock key (two copies)

3.2 Mounting the Units

- Knockouts
- Hanging the Rotem Trio Controller Unit
- Hanging the Rotem Trio Expansion 70 Unit

3.2.1 KNOCKOUTS

- On the bottom of the Rotem Trio Expansion 70 are knockouts used to route the high voltage cables.

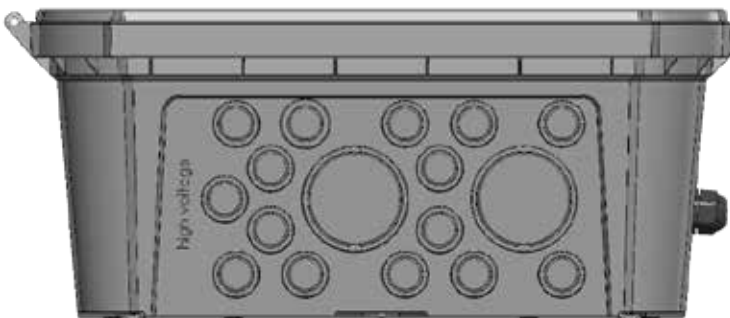

Figure 8: Rotem Trio Expansion 70 High Voltage Knockouts

- On the side of the Rotem Trio Expansion 70 are knockouts used to route the low voltage cables.

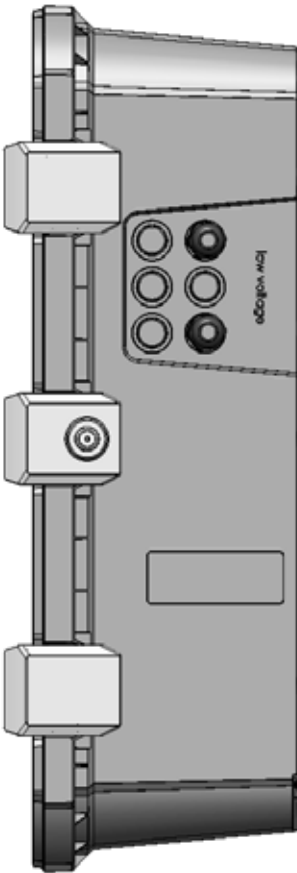

Figure 9: Rotem Trio Expansion 70 Low Voltage Knockouts

CAUTION Run low voltage cables through one knockout and high voltage relay cables through a separate knockout. Do not place them in the same knockout!

- On the bottom of the Rotem Trio Controller are knockouts used to route the cables plus one designated communication port (refer to Figure 25, page 43).

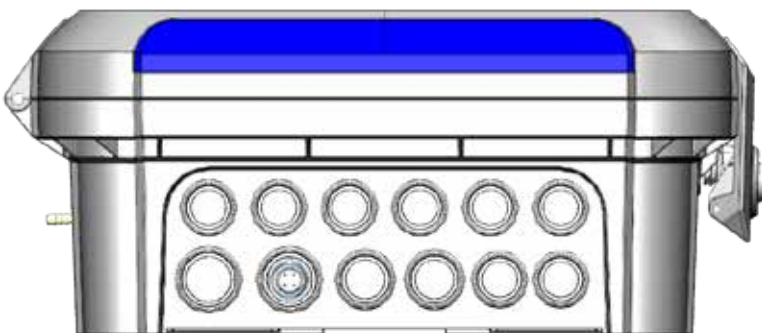

Figure 10: Rotem Trio Controller Knockouts

- Using a screwdriver and a hammer, gently apply pressure to the knockouts.
- Only open the holes that you require.
- Munters recommends removing the knockouts before mounting the unit.

3.2.2 HANGING THE ROTEM TRIO CONTROLLER UNIT

1. Attach the bracket to the wall (using the supplied screws).

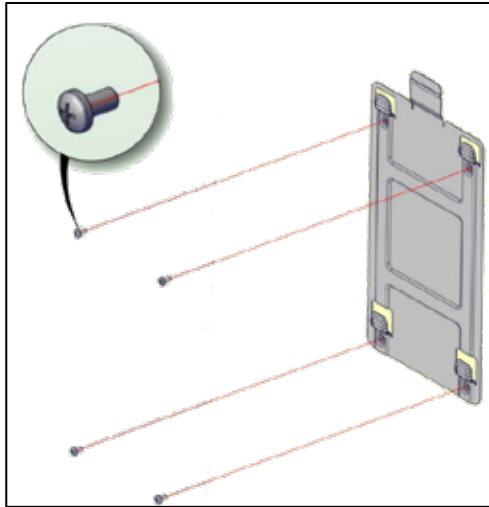

Figure 11: Hang the Bracket

2. Hang the Trio on the bracket.

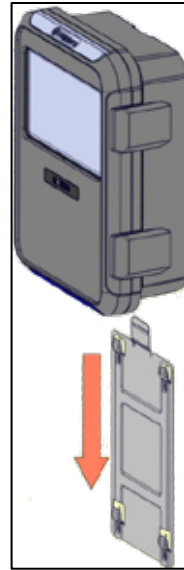

Figure 12: Hanging the Unit

3. Close the Trio enclosure lid carefully and tightly. Use RTV silicon or equivalent sealant to seal the cable holders.

CAUTION Munters strongly recommends that you seal all entry spots with RTV silicon. Failure to do so can lead to damage to the unit.

4. After installation is completed, operate the Trio for a few hours and re-check for proper operation.

3.2.3 HANGING THE ROTEM TRIO EXPANSION 70 UNIT

Rotem Trio Expansion 70 comes with two hanging brackets.

⚠ Hang the Rotem Trio Expansion 70 on a wall capable of supporting the unit's weight! (31 pounds).

1. Use the supplied (long) screws to attach the bracket to the wall.

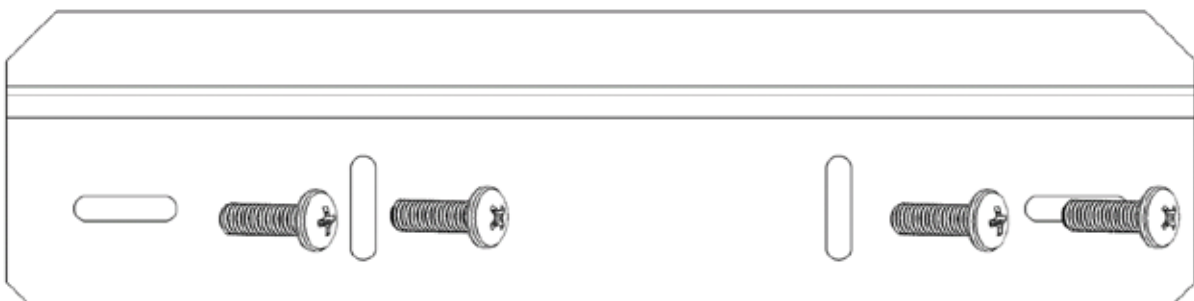

Figure 13: Wall bracket

2. Attach to the Rotem Trio Expansion 70:

- the second hanging bracket

- o the securing brackets

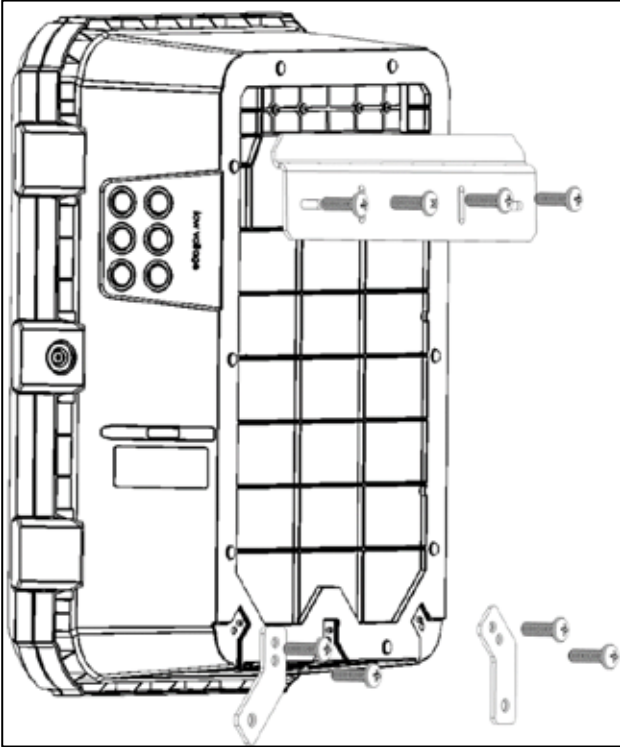

Figure 14: Unit brackets

3. Hang the Rotem Trio Expansion 70 on the wall bracket.
4. Use the supplied short screws to adhere the securing brackets to the wall.

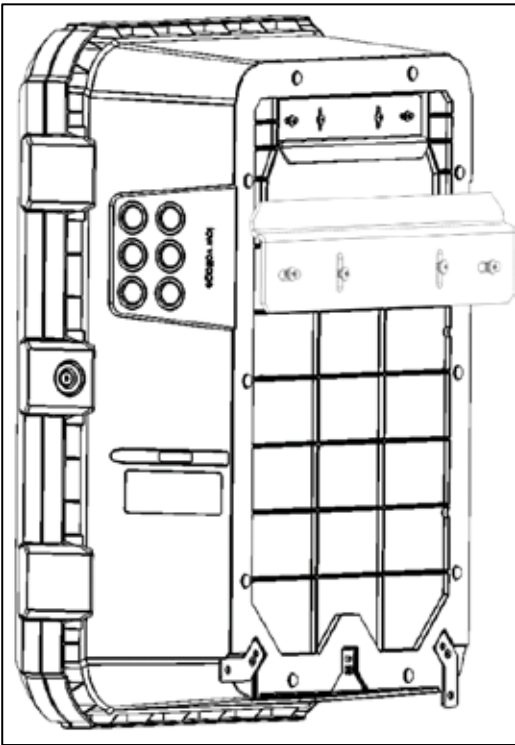

Figure 15: Mounting Completed

3.3 Layouts

- Rotem Trio Expansion Layout
- Rotem Trio Controller Layout

3.3.1 ROTEM TRIO EXPANSION LAYOUT

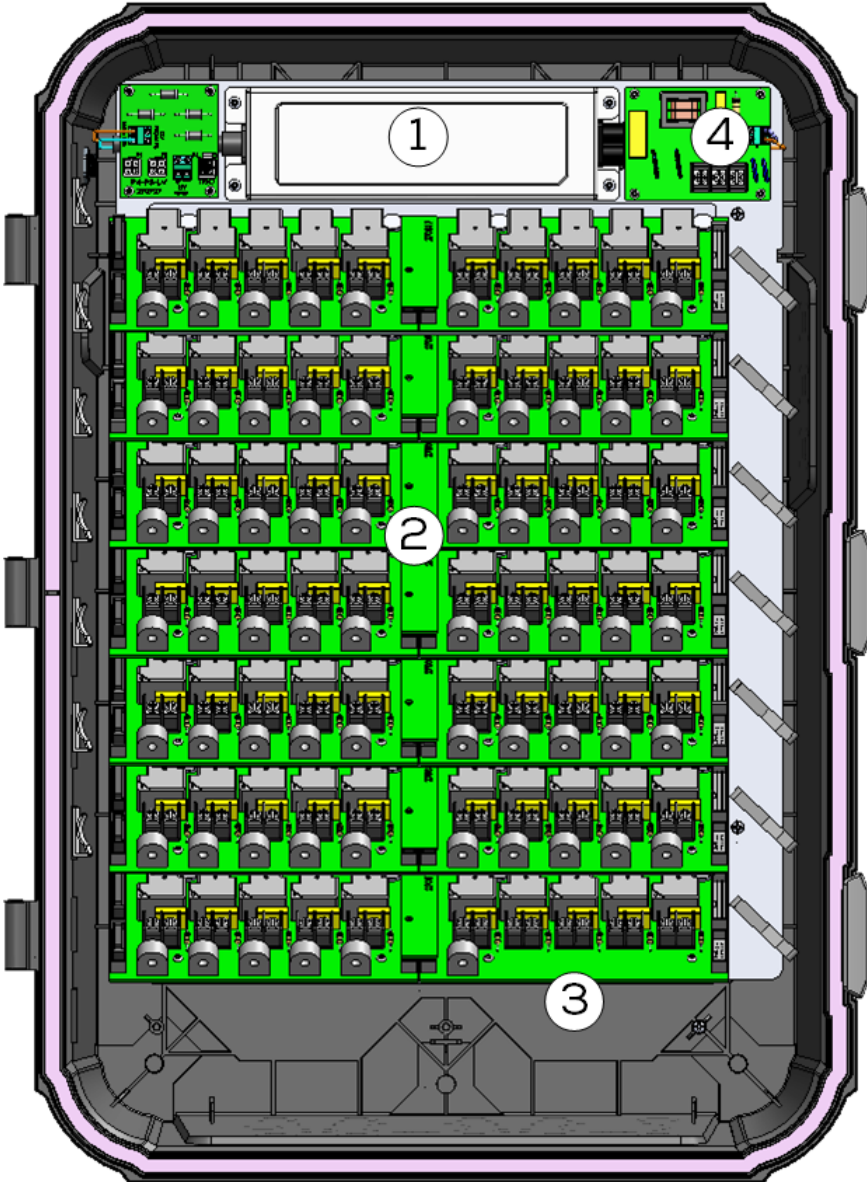

Figure 16: Rotem Trio Expansion 70 Board Layout

Table 1: Rotem Trio Expansion 70 Relays

Number	Description
1	Power supply (See Figure 17)
2	66 current sense relays (Normally Open, Normally Closed)
3	Four winch relays (do not include current sensors)
4	Input power

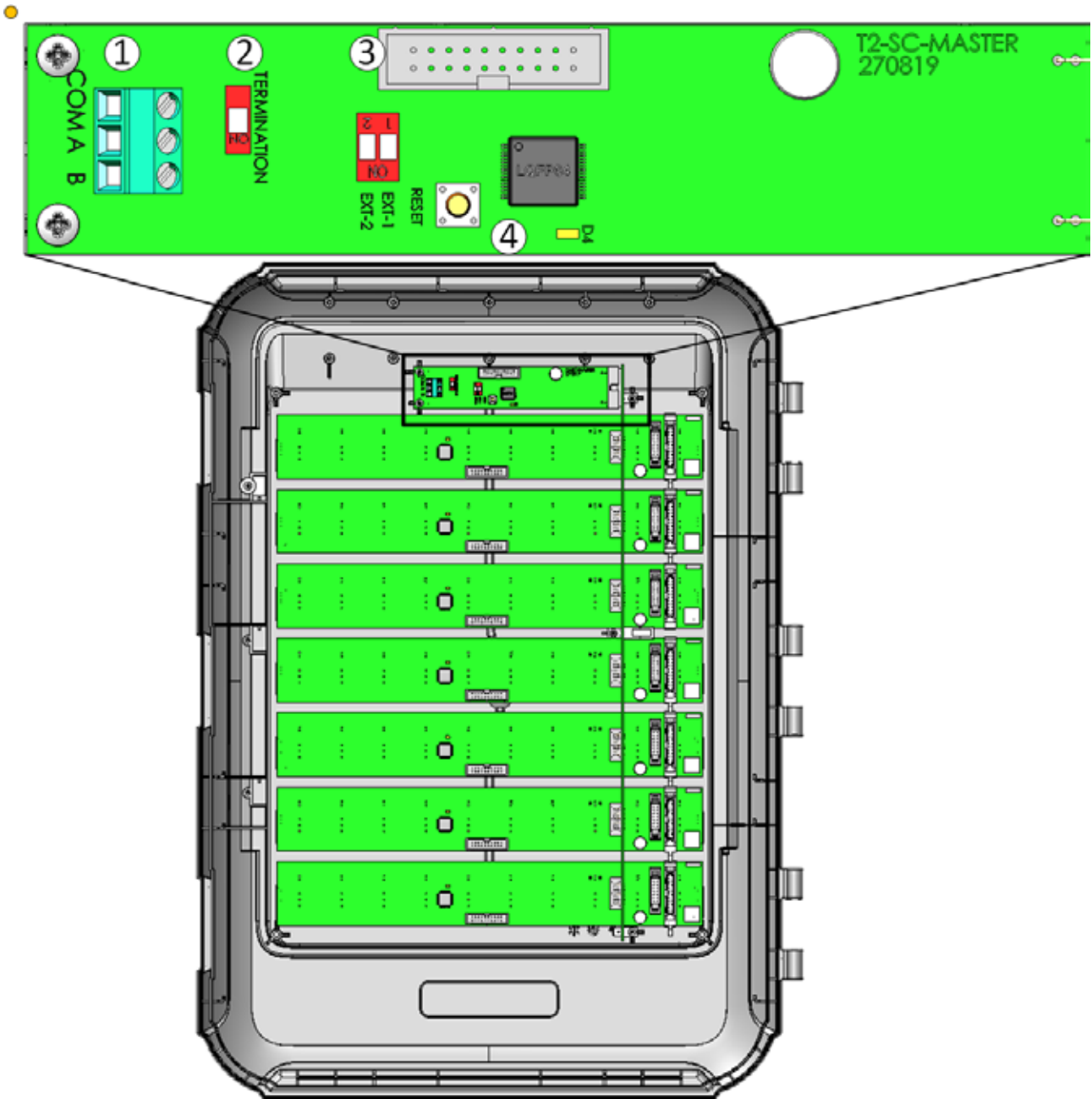

Figure 17: Rotem Trio Expansion 70 Door Controls

Table 2: Rotem Trio Expansion 30 Switch Door

Number	Description
1	RS-485 ports (communication with Trio Controller, refer to Figure 26, page 44)
2	Termination dipswitch (refer to Termination, page 78)
3	Address dipswitch (refer to Address, page 45)
4	CPU reset button (press if the LED is not blinking)

3.3.2 ROTEM TRIO CONTROLLER LAYOUT

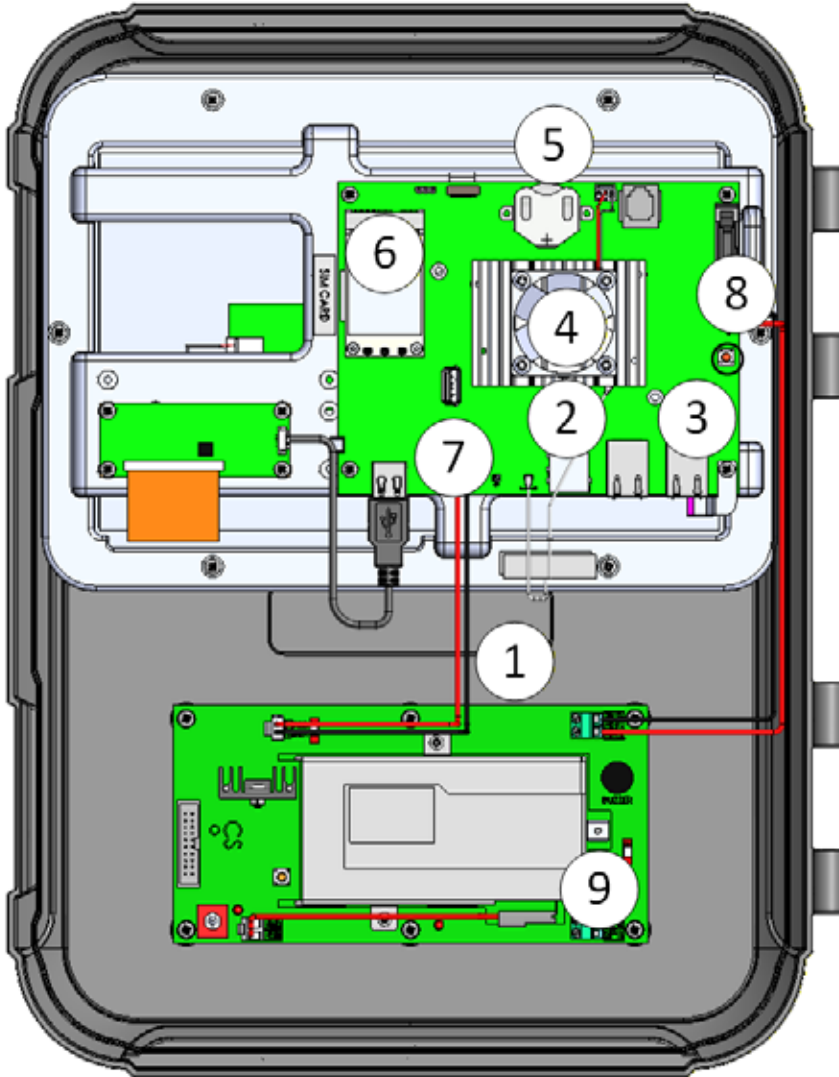

Figure 18: Rotem Trio Controller Display Board Layout

Table 3: Rotem Trio Controller Display layout key

Number	Description	Number	Description
1	Wireless antenna	5	3V Battery
2	SD Port	6	Modem
3	Ethernet Port	7	USB Port
4	Heat Sink	8	Reset Button
		9	Backup Battery (refer to Appendix A: Alarm Backup Battery, page 143)

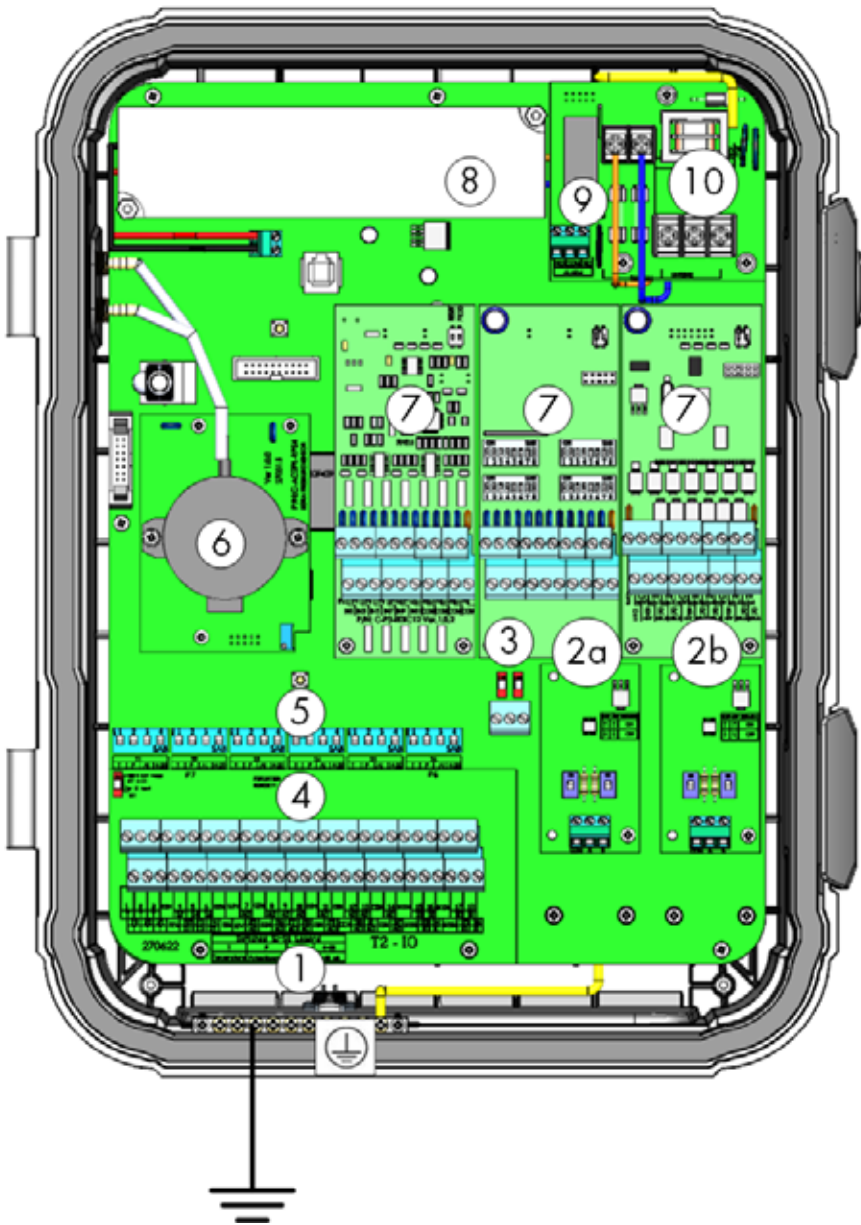

Figure 19: Rotem Trio Controller Main Board Layout

Table 4: Rotem Trio Controller Board layout key

Number	Description
1	Ground strip
2a	Communication card to external devices (for example RLED or RSU)
2b	Communication card to Rotem Trio Expansion 70
3	Termination dipswitches
4	Input ports (see below for break down)
5	Dipswitches
6	Static pressure sensor

Number	Description
7	Analog Input/Digital Input/Scale Card (any combination) <ul style="list-style-type: none"> · 1 analog input · 1 digital input · 1 scale card <i>NOTE The CMOS battery is located under the card on the left.</i>
8	Power supply
9	Alarm relay
10	Power ports

Table 5: Trio Board I/O Details

Function	Number of ports
Analog Input	
· Dedicated RTS ports	6
· Temperature/0-3V/4-20mA/Potentiometer	6
Digital Input ports	8
Analog Output ports	16



Figure 20: Dipswitches, expanded

- One dipswitch only in each set is raised.
- Only raise a dipswitch if a device is wired to an S port.

3.4 Rotem Trio Expansion 70 Wiring Diagrams

- Power
- High Voltage Relays
- Winch Card Wiring
- Completing the Wiring

3.4.1 POWER

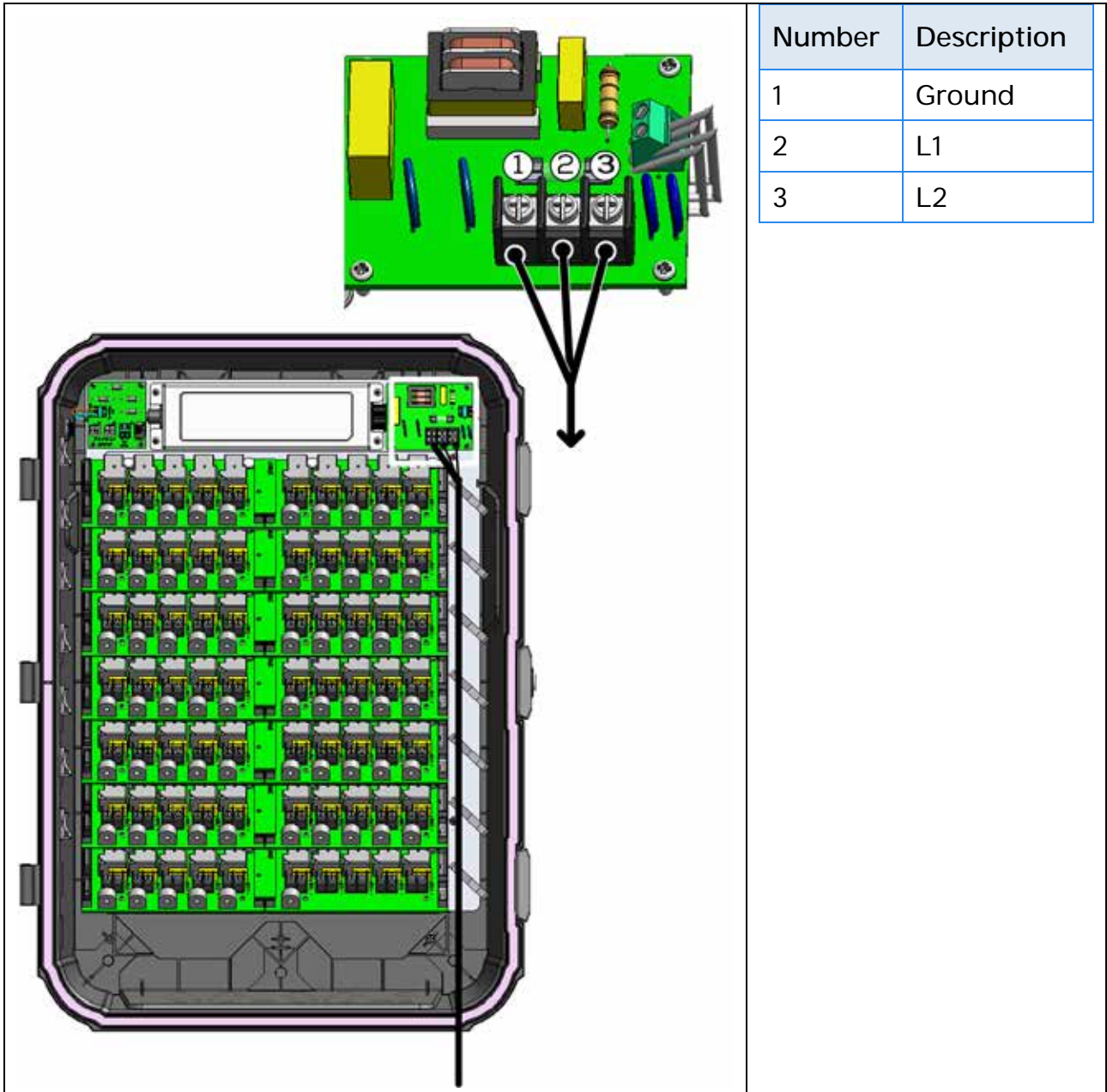

Figure 21: Rotem Trio Expansion 70 Power Supply Wiring Diagram

3.4.2 HIGH VOLTAGE RELAYS

This procedure details how to connect output relays to high voltage devices.

1. Connect the control phase commons to the relays' contacts (the common wire to all relays with the same function).

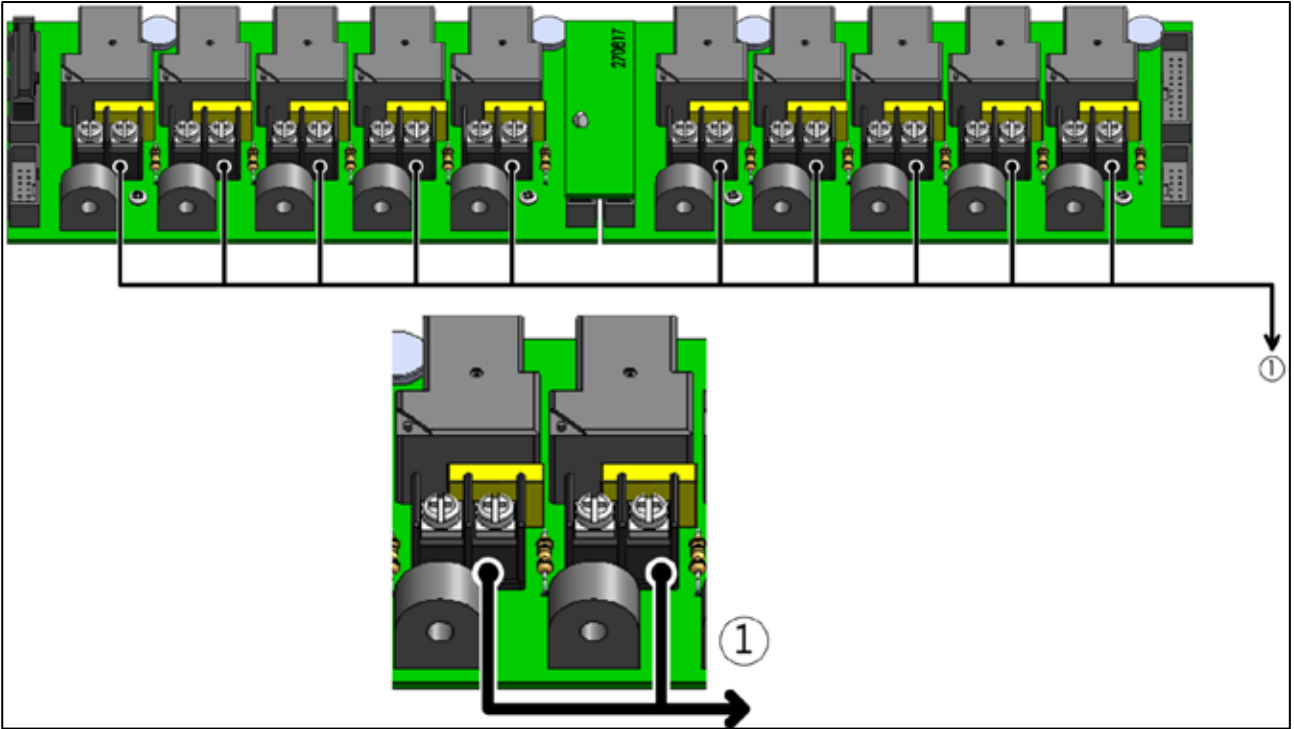

Figure 22: Control Phase Commons

Table 6: Control Phase Commons layout key

Number	Description
1	Phase common

2. Connect the relay cables to each device.

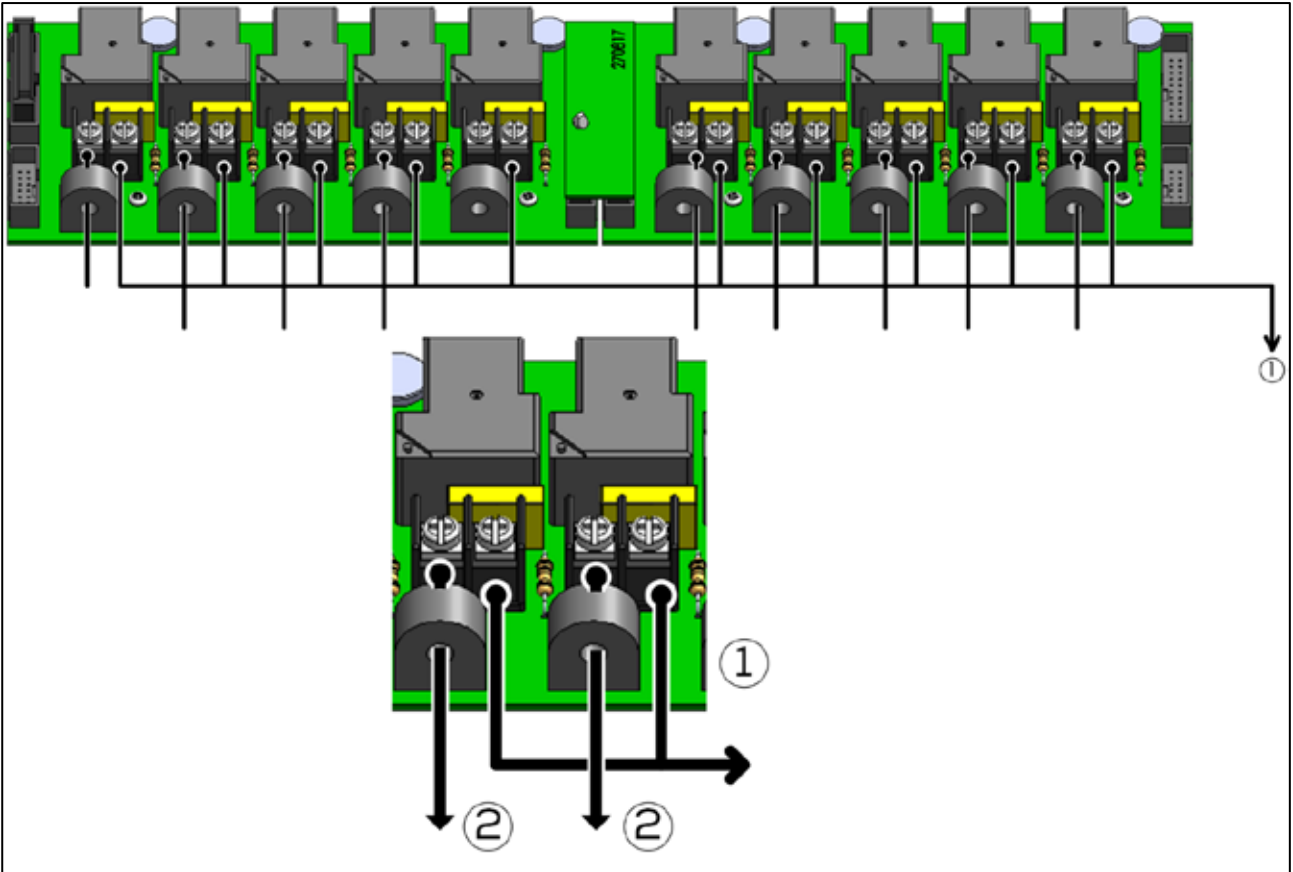

Figure 23: Relay Cable Connections

Table 7: Relay Cable layout key

Number	Description
1	Phase common
2	Cable to device

3.4.3 WINCH CARD WIRING

Winch cards are equipped with two Normally Close relays.

- 1. Connect separate control phase commons for each inlet or curtain.

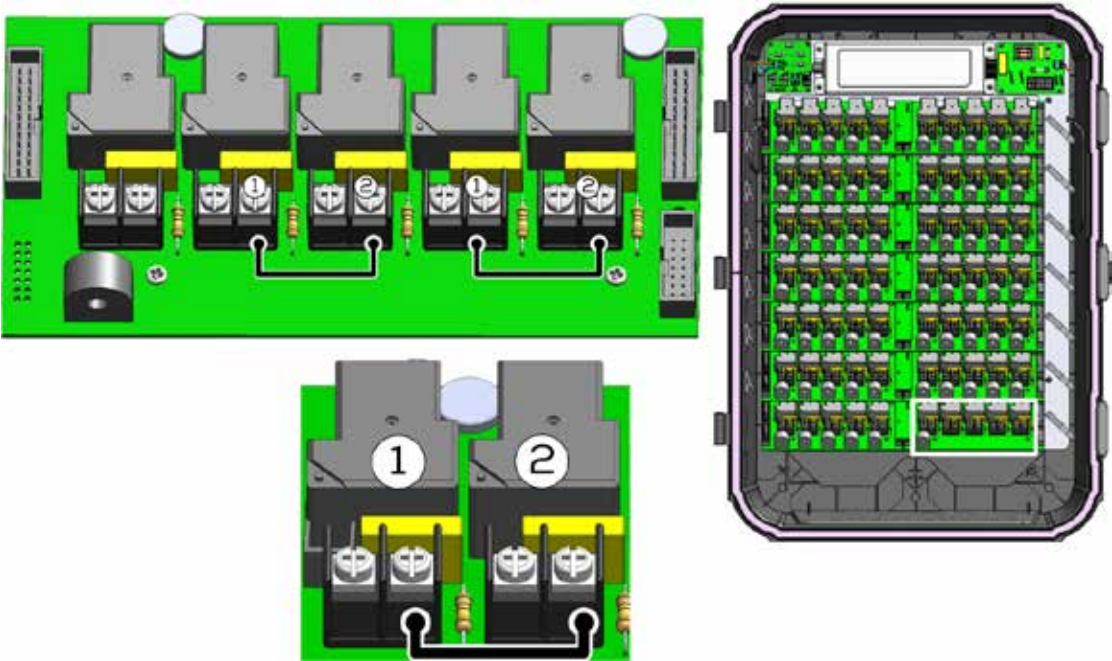

Figure 24: Winch Card Control Phase Commons

Figure 20 Key	
1	Open curtain (Normally Open Relay)
2	Close curtain (Normally Open Relay)

3. Connect the output wires to the required device.

	<table border="1"> <thead> <tr> <th colspan="2">Figure 21 Key</th> </tr> </thead> <tbody> <tr> <td>1</td> <td>Open curtain (Normally Closed (NC) relay is wired to the opening gear)</td> </tr> <tr> <td>2</td> <td>Close curtain (Normally Open (NO) relay is wired to the opening gear)</td> </tr> <tr> <td>3</td> <td>Connect control phase wire to L1 or L2 power port OR RBU device.</td> </tr> </tbody> </table>	Figure 21 Key		1	Open curtain (Normally Closed (NC) relay is wired to the opening gear)	2	Close curtain (Normally Open (NO) relay is wired to the opening gear)	3	Connect control phase wire to L1 or L2 power port OR RBU device.
Figure 21 Key									
1	Open curtain (Normally Closed (NC) relay is wired to the opening gear)								
2	Close curtain (Normally Open (NO) relay is wired to the opening gear)								
3	Connect control phase wire to L1 or L2 power port OR RBU device.								

Figure 25: Connecting the Output Wire to Inlets/Curtains

3.4.4 COMPLETING THE WIRING

1. Locate the bag of stickers placed on the inside of the controller door.
2. On the sticker below each relay, write the name of the device connected to the relay.

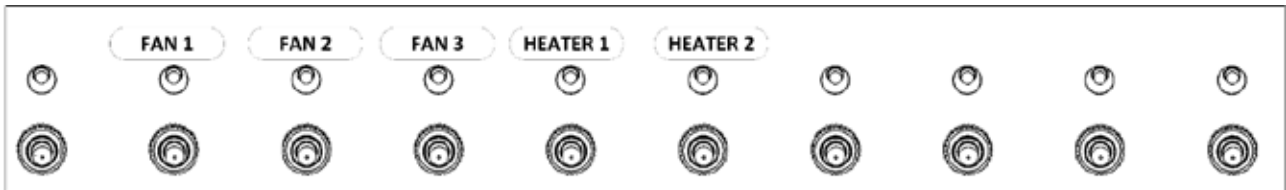

Figure 26: Controller labels

3.5 Rotem Trio Controller Wiring Diagrams

- Alarms and Power
- Internet Connection
- Rotem Trio Expansion 70 – Rotem Trio Controller Communication
- Board Wiring
- Card Wiring
- Trio RPS
- RSU Wiring

Rotem Trio Controller supports two types of input cards:

- Dedicated analog input/analog output/digital input ports (Board Wiring, page 46)
- Optional analog input cards/digital input card/scale card (Card Wiring, page 61)

3.5.1 ALARMS AND POWER

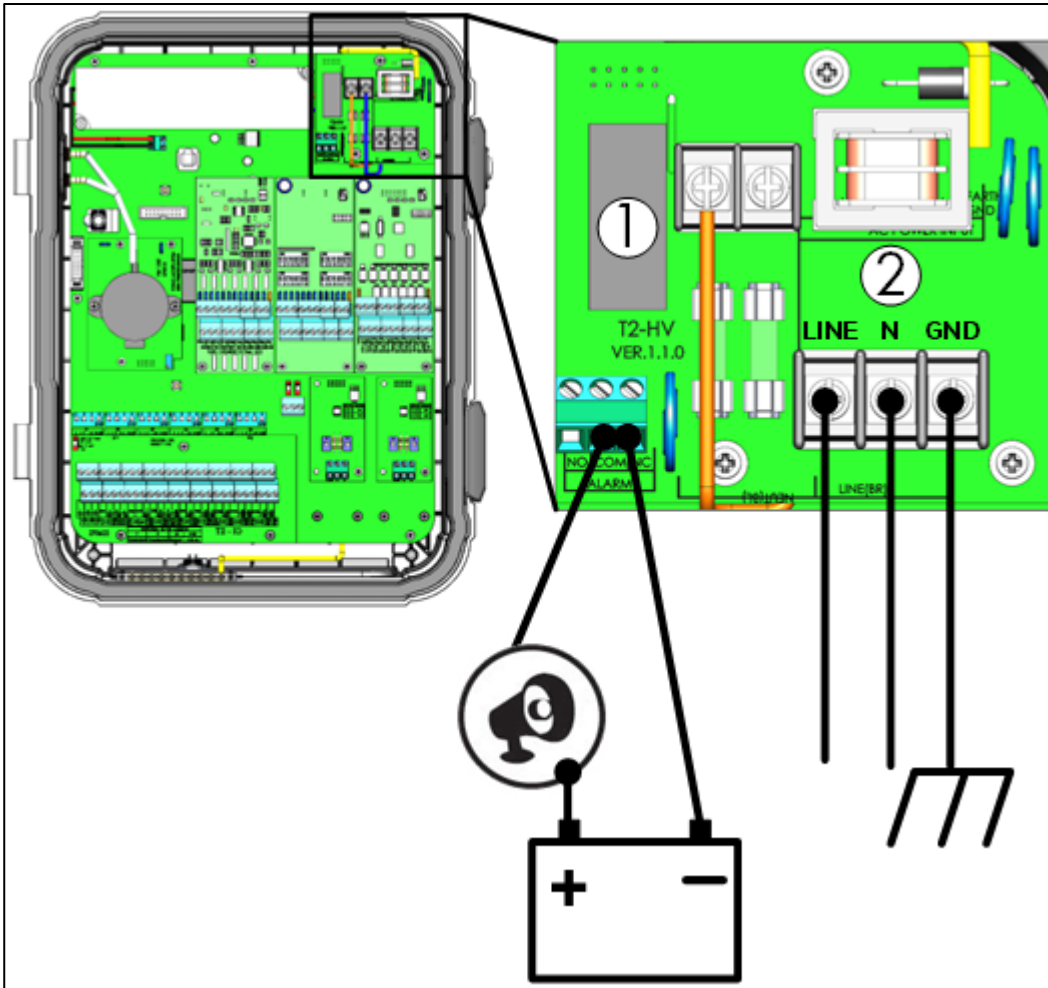

Figure 27: Alarm Relay and Power Ports

Table 8: Alarm relay and power layout key

Number	Description
1	Alarm relay
2	Power ports

- Connect the light or siren device to the alarm relay.

3.5.2 INTERNET CONNECTION

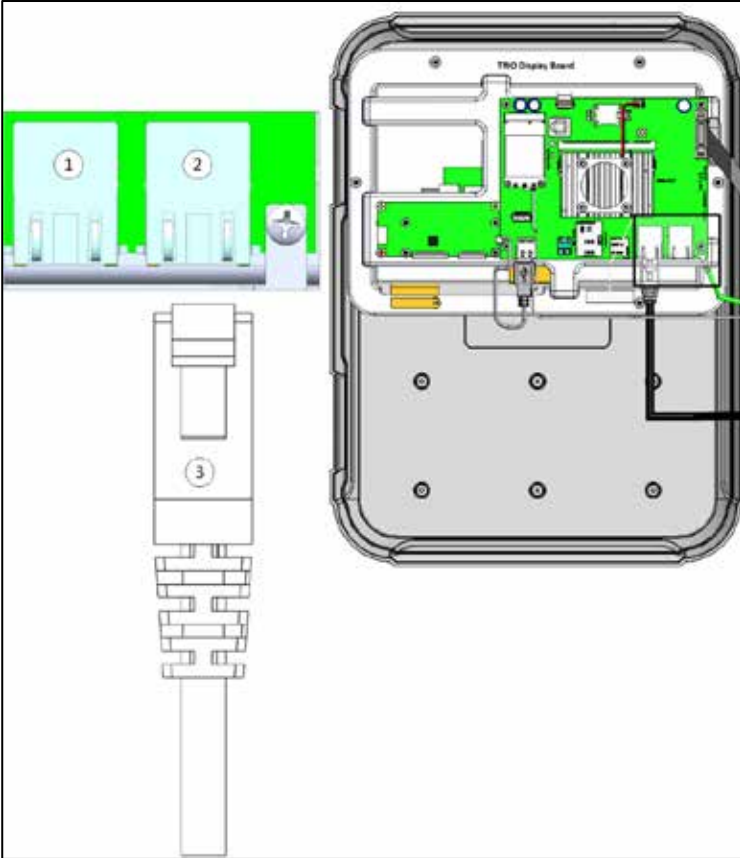

Figure 28: Ethernet Port

CAUTION Connect the internet cable to port 2. Do not connect the cable to port 1.

Number	Description
1	Internal port (do not use this port)
2	Ethernet port
3	RJ-45 cable

3.5.3 ROTEM TRIO EXPANSION 70 – ROTEM TRIO CONTROLLER COMMUNICATION

Connect the Rotem Trio Controller to the Expansion unit in one of two ways:

- Cable Connection
- RS-485 Wiring
- Address
- Restart

3.5.3.1 Cable Connection

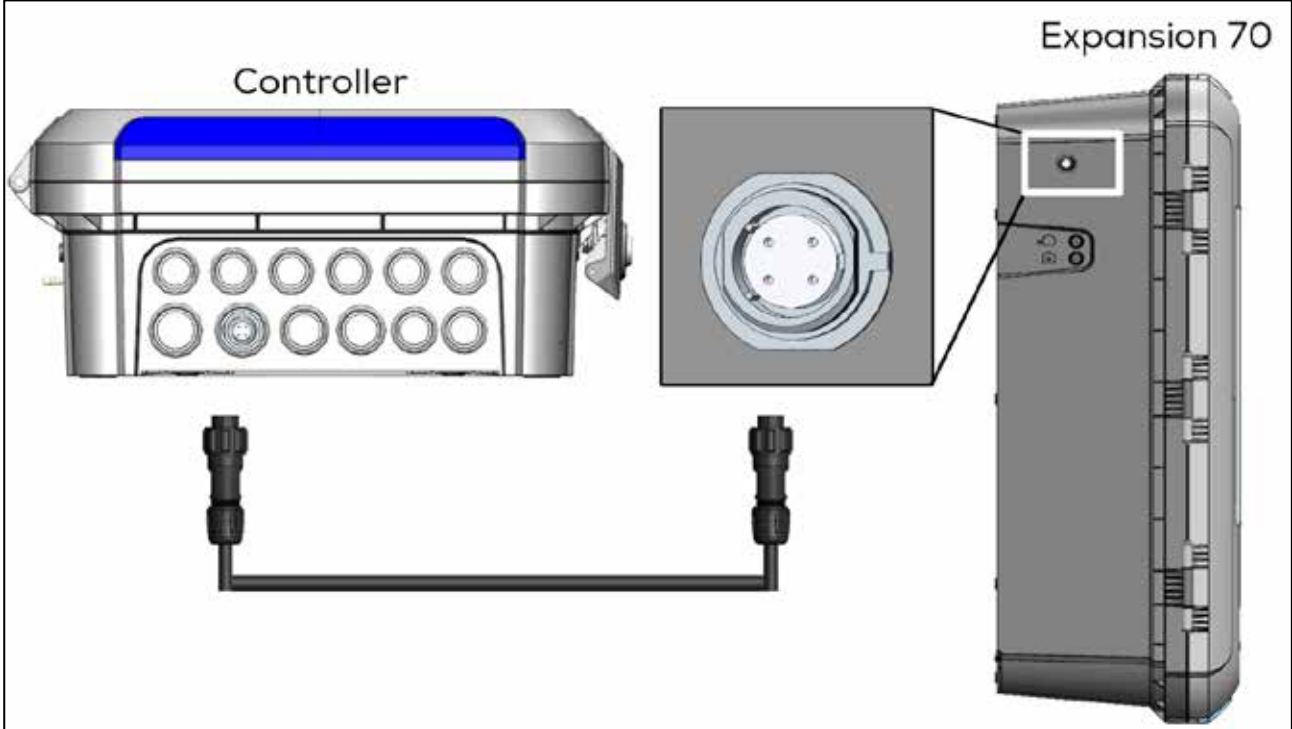

Figure 29: Rotem Trio Expansion 70 – Rotem Trio Controller Cable Connection

3.5.3.2 RS-485 Wiring

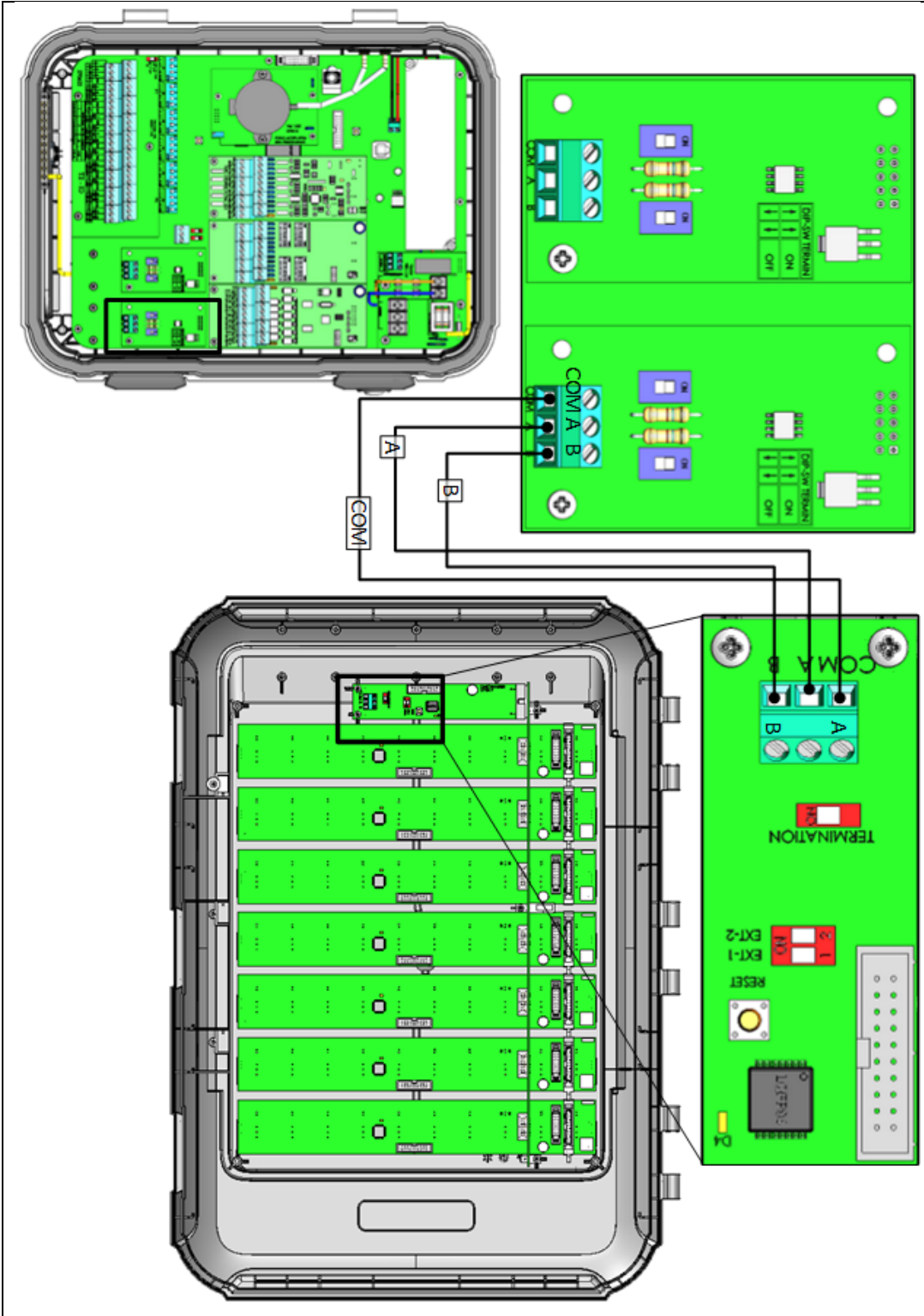

Figure 30: Rotem Trio Expansion 70 – Rotem Trio Controller RS-485 Wiring

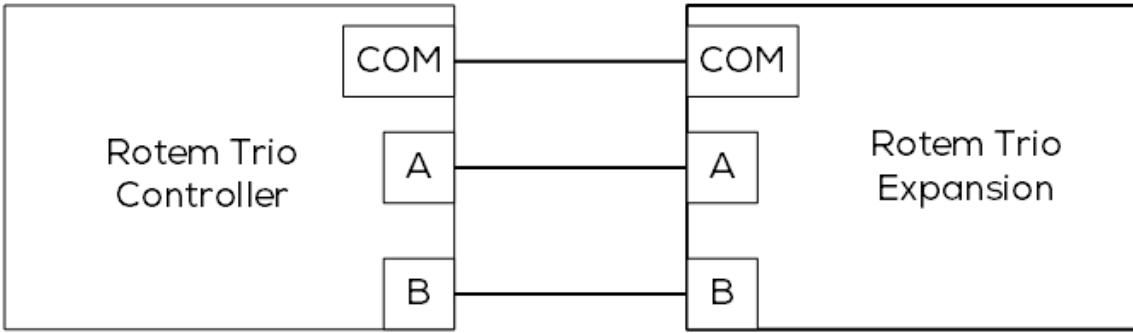

Figure 31: Rotem Trio Expansion 70 – Rotem Trio Controller RS-485 Schematic

The cable between the controller and the expansion unit should be a 4 wire twisted shielded cable (22 or 24 AWG).

NOTE After wiring the Controller to the Expansion, perform a Reset Factory Default (Refer to Restart, page 46).

3.5.3.3 Address

The Rotem Trio can support one expansion unit. Verify that both dipswitches in the Modbus Address are set to ON.

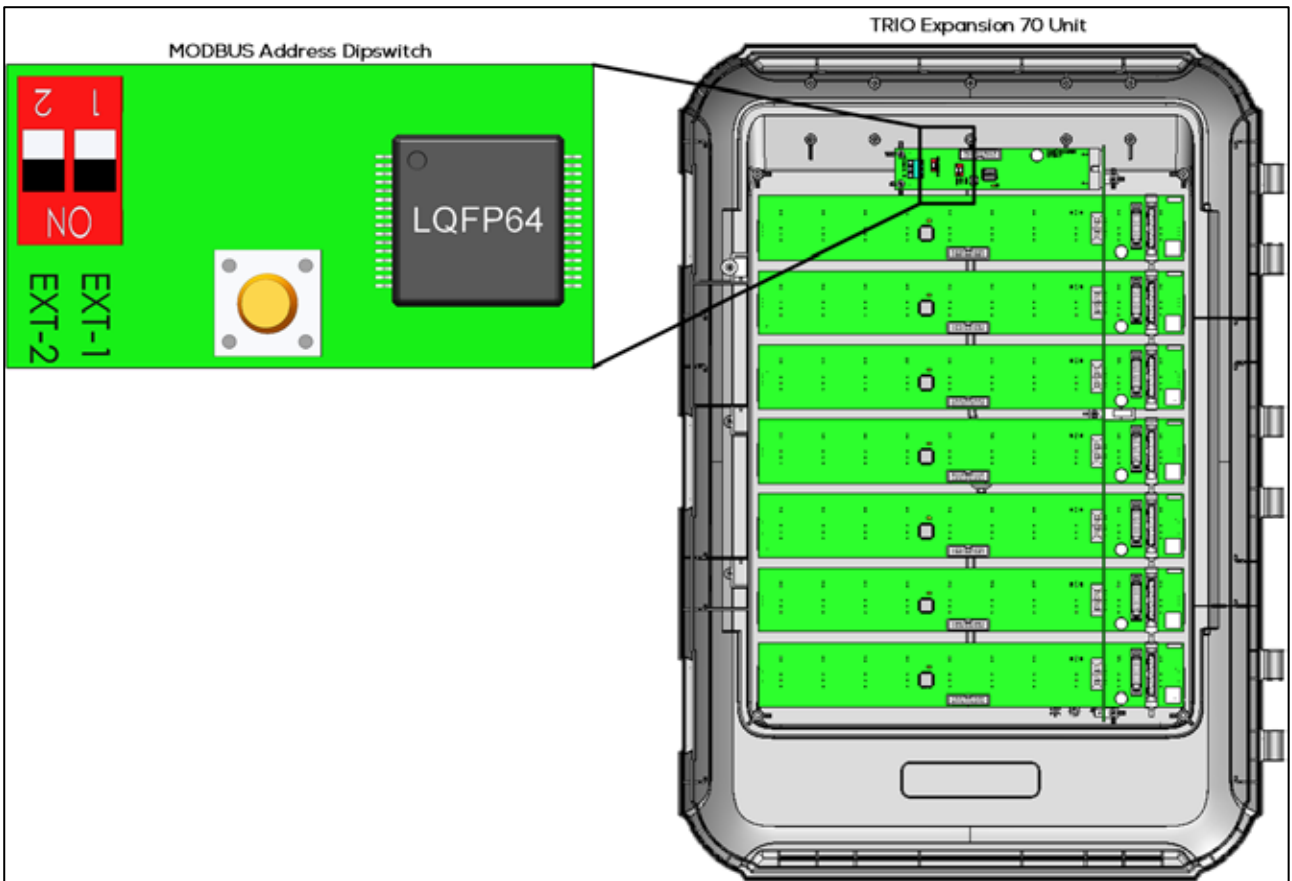



Figure 32: Expansion Address

3.5.3.4 Restart

After connecting the two units reset the factory settings.

1. Go to System > General Settings > .
2. Click .
3. Follow the on-line instructions. You have the option of backing up the settings. Refer to the User Manual for more information.

3.5.4 BOARD WIRING

- Analog Output Devices
- Digital Input Devices
- Analog Input Devices

3.5.4.1 Analog Output Devices

Trio supports analog control over a variety of devices. Connect analog output devices to an AO and a COM port. Do not connect the devices to a DCOM port!

CAUTION Ground these devices!

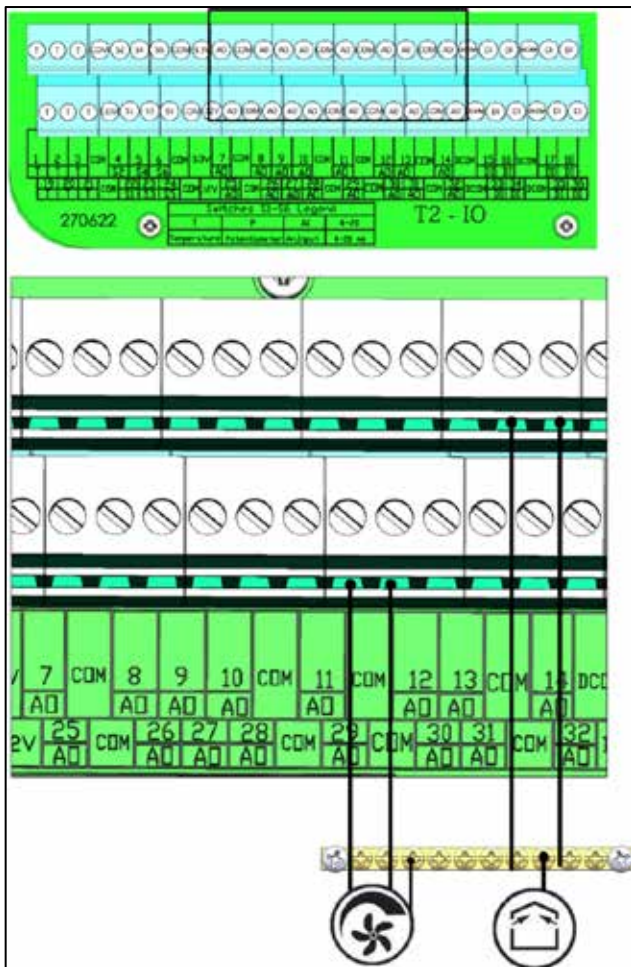

Figure 33: Analog Output devices (examples)

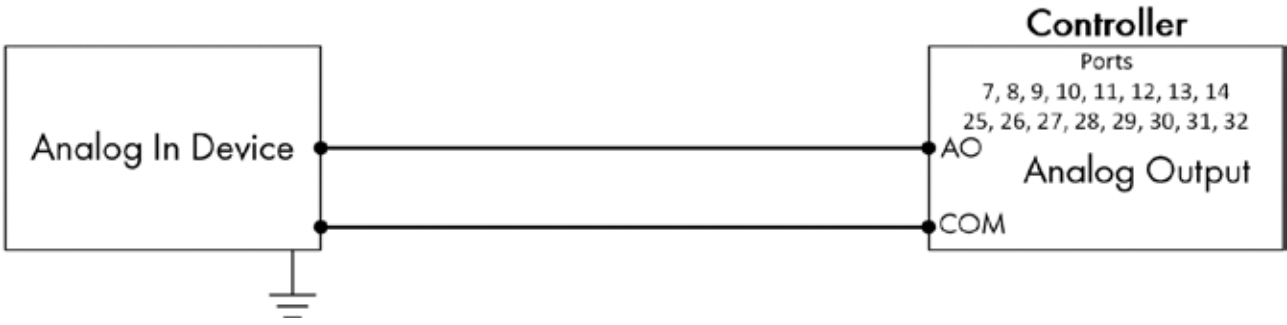

Figure 34: Analog Device Wiring Schematic

3.5.4.2 Digital Input Devices

Connect digital input devices to a DI and a DCOM port. Ground these devices!

CAUTION Do not connect the devices to a COM port!

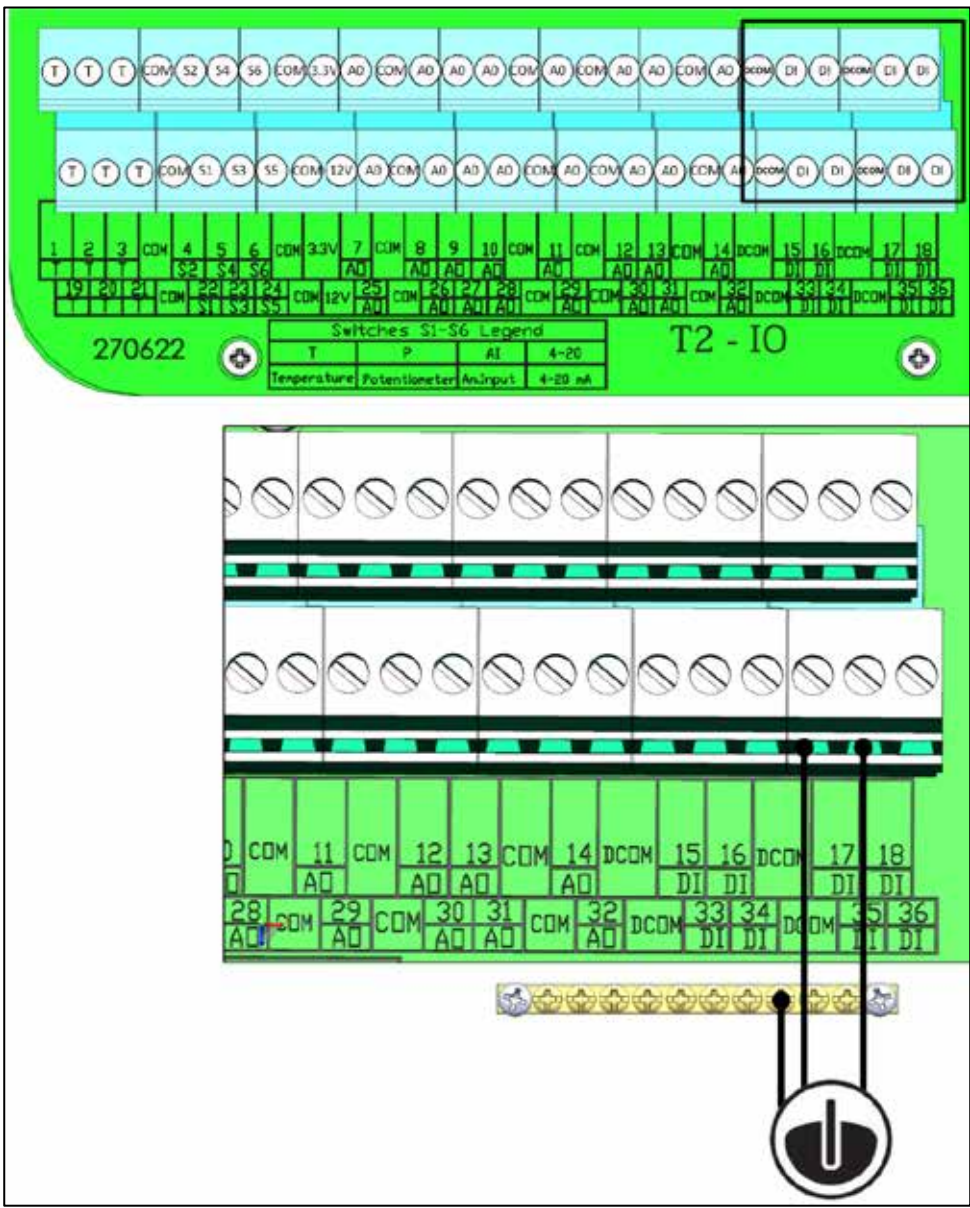

Figure 35: Board Wiring: Digital Input devices (example)

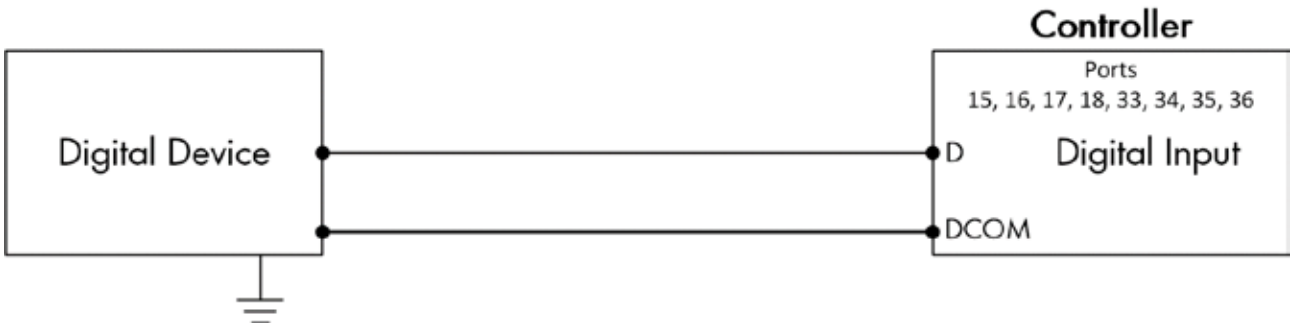

Figure 36: Digital Device Wiring Schematic

3.5.4.3 Analog Input Devices

- CO2 Sensor Wiring
- Temperature Sensor Wiring
- Humidity Sensor Wiring
- Potentiometer Wiring
- Ammonia Sensor Wiring
- WOD Water Pressure Sensor Wiring
- Light Sensor Wiring

3.5.4.3.1 CO2 Sensor Wiring

Refer to the [CO2 Sensor Manual](#) for details on installing this unit.

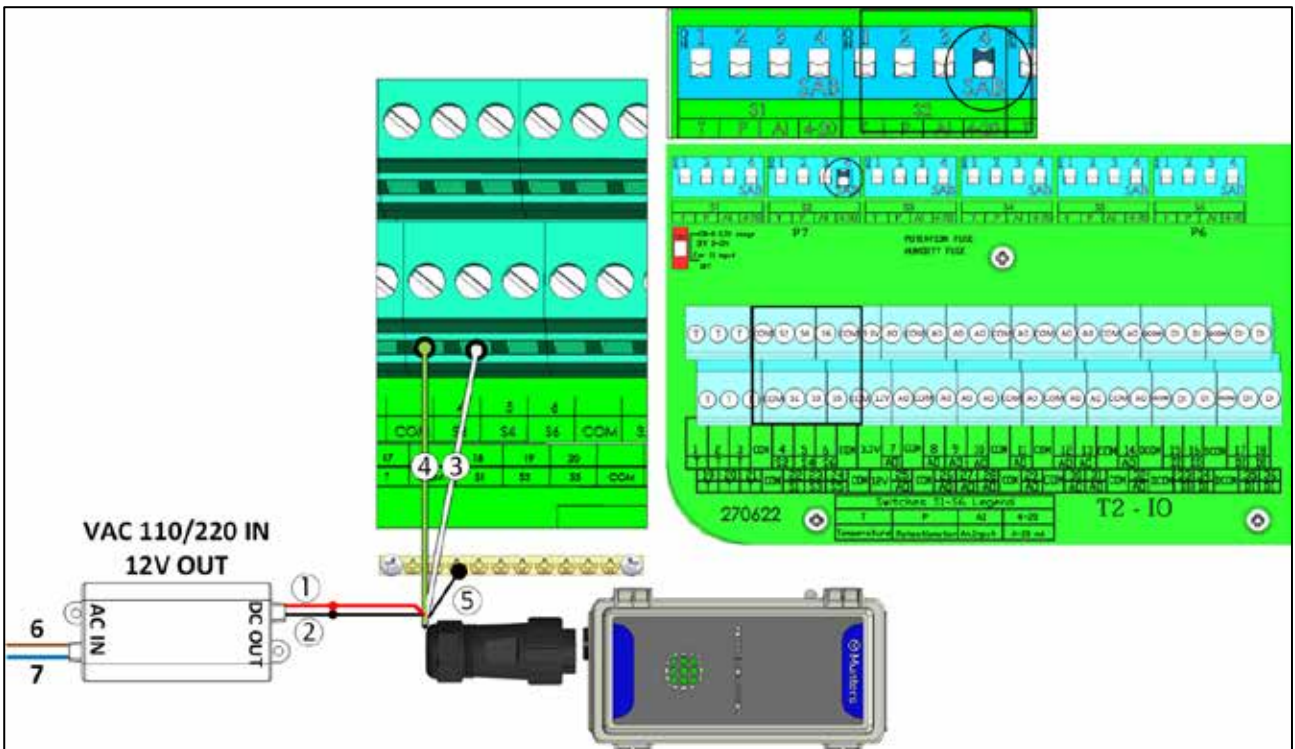

Figure 37: Board Wiring: CO2 Sensor (P/N: 913-03-XXXX)

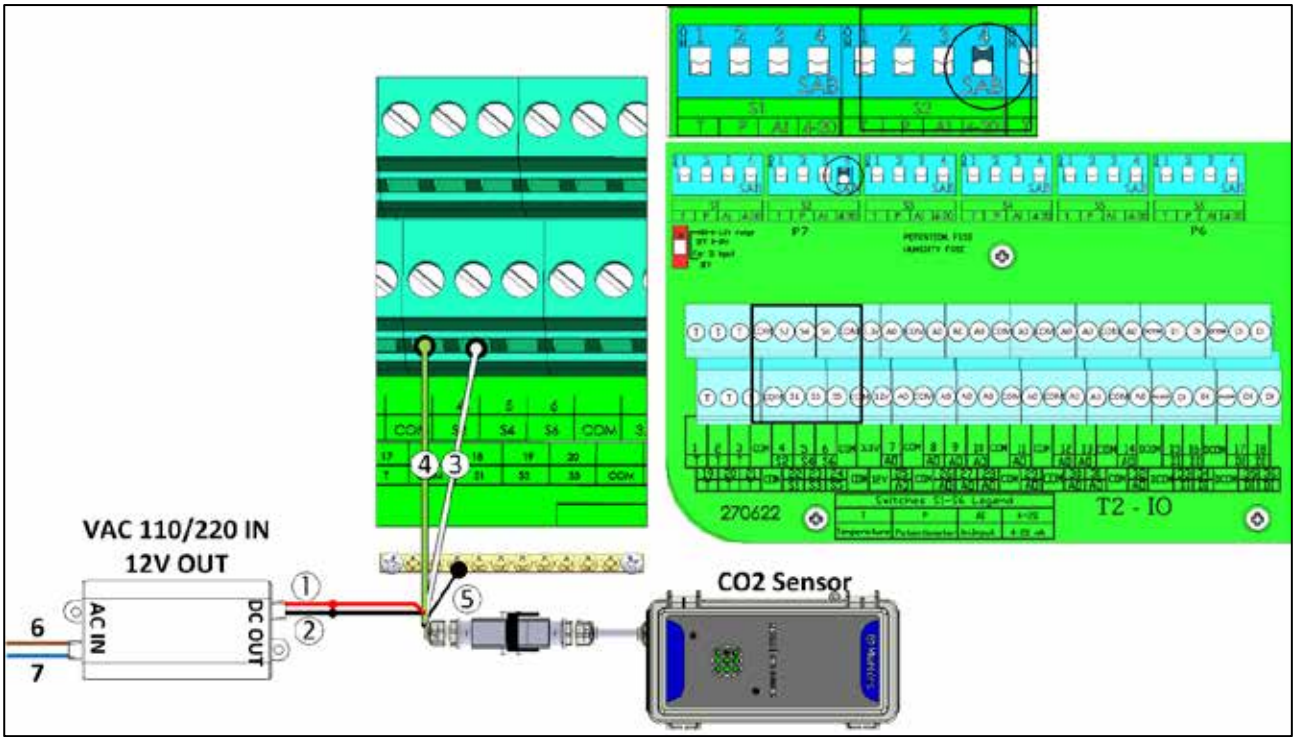

Figure 38: Board Wiring: CO2 Sensor (P/N: 913-01-XXXXX)

Number	Function
1	S port
2	COM port
3	Shield wire
4	Brown wire: phase
5	Blue wire: neutral
6	Red wire: +12VDC
7	Black wire: -12VDC

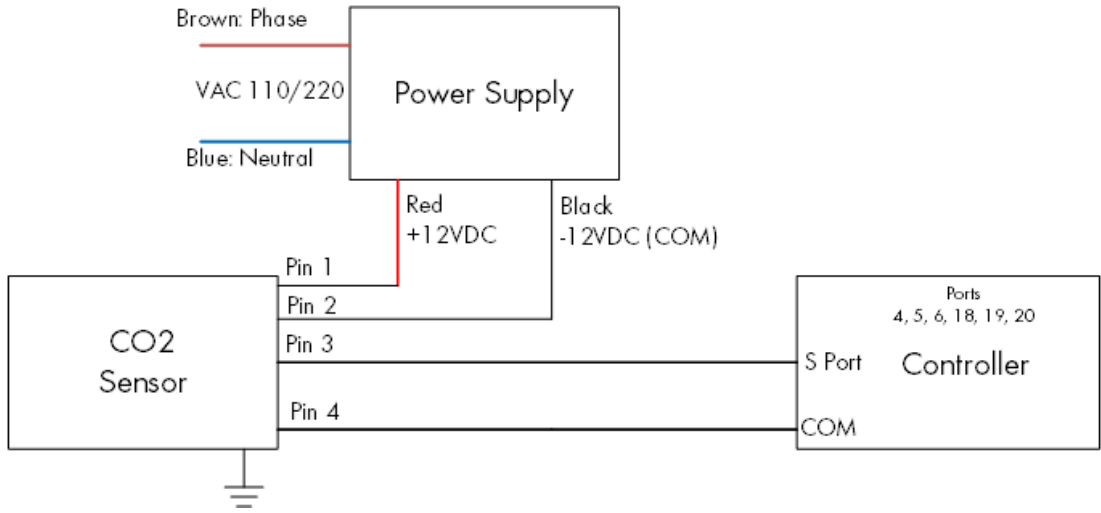

Figure 39: CO2 Sensor Wiring Schematic

CAUTION *Ground these devices!*

CAUTION *Do not connect the devices to a DCOM port!*

3.5.4.3.2 Temperature Sensor Wiring

Refer to the [RTS-2 Manual](#) for details on this sensor.

- Note:
 - Wire all designated T ports before wiring the RTS sensors to the S ports.
 - Connect the black wire to a COM port, not a DCOM port.

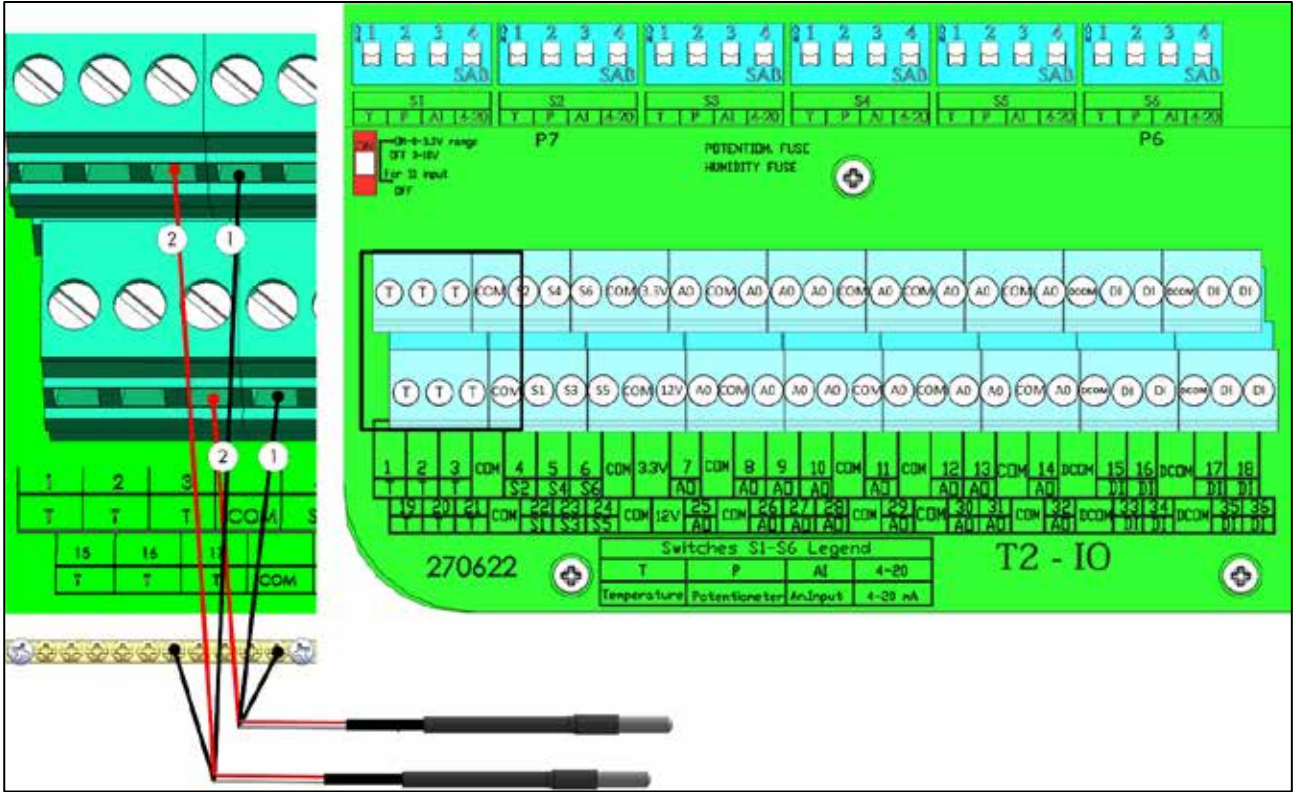

Figure 40: Board Wiring: RTS Wiring

Number	Function
1	COM port (black wire)
2	T port (red wire)

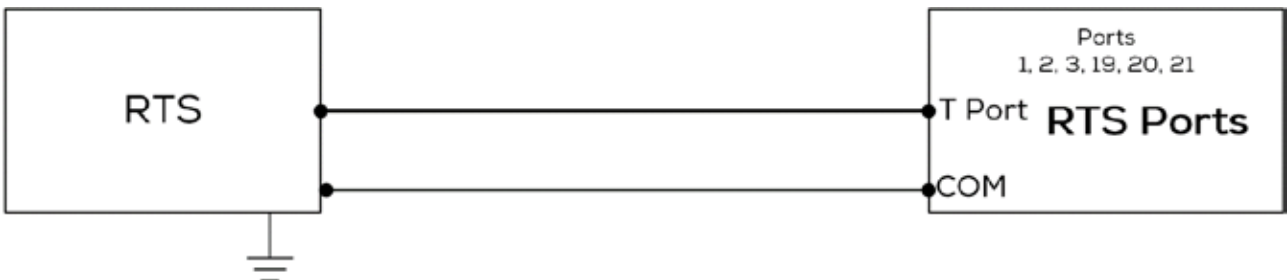

Figure 41: RTS Wiring Schematic

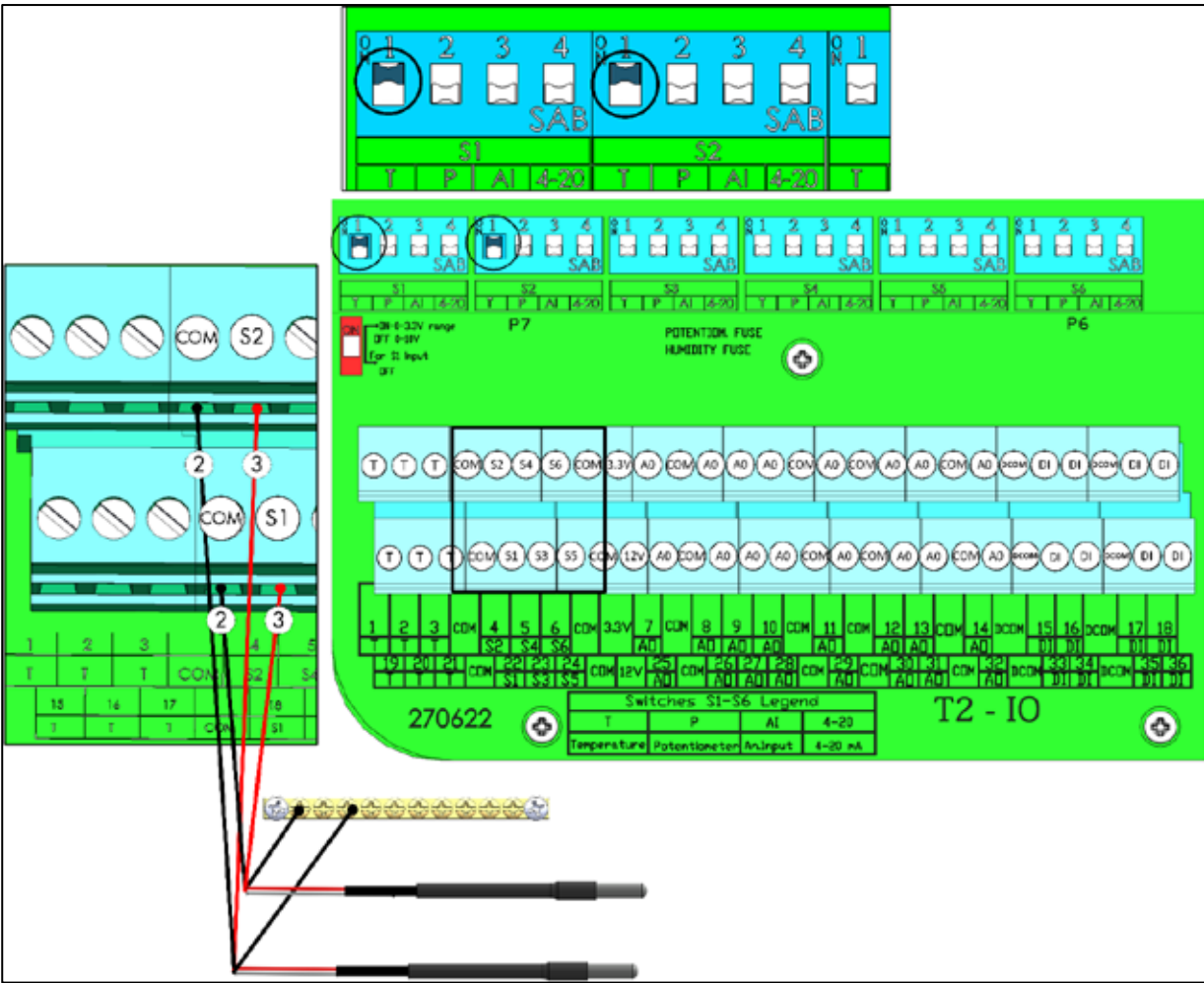

Figure 42: RTS S Port Wiring

Number	Function
2	COM port (black wire)
3	S port (red wire)

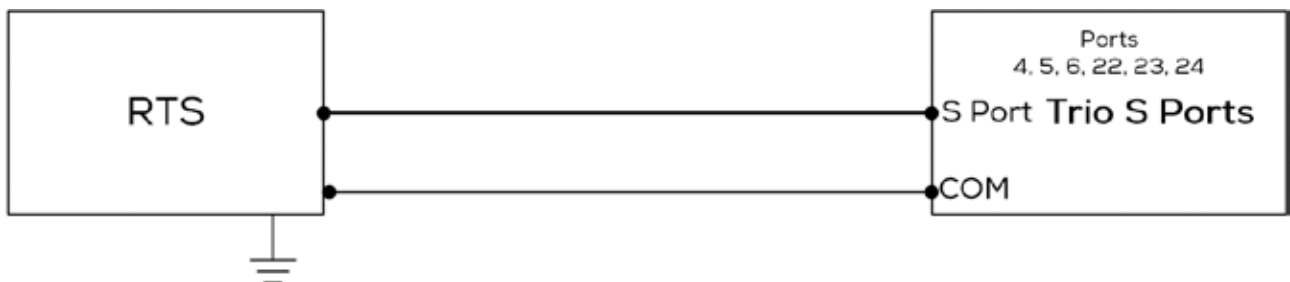

Figure 43: RTS S Port Wiring Schematic

- Connect each RTS sensor to a:
 - T port
 - COM port
 - Grounding strip!

3.5.4.3.3 Humidity Sensor Wiring

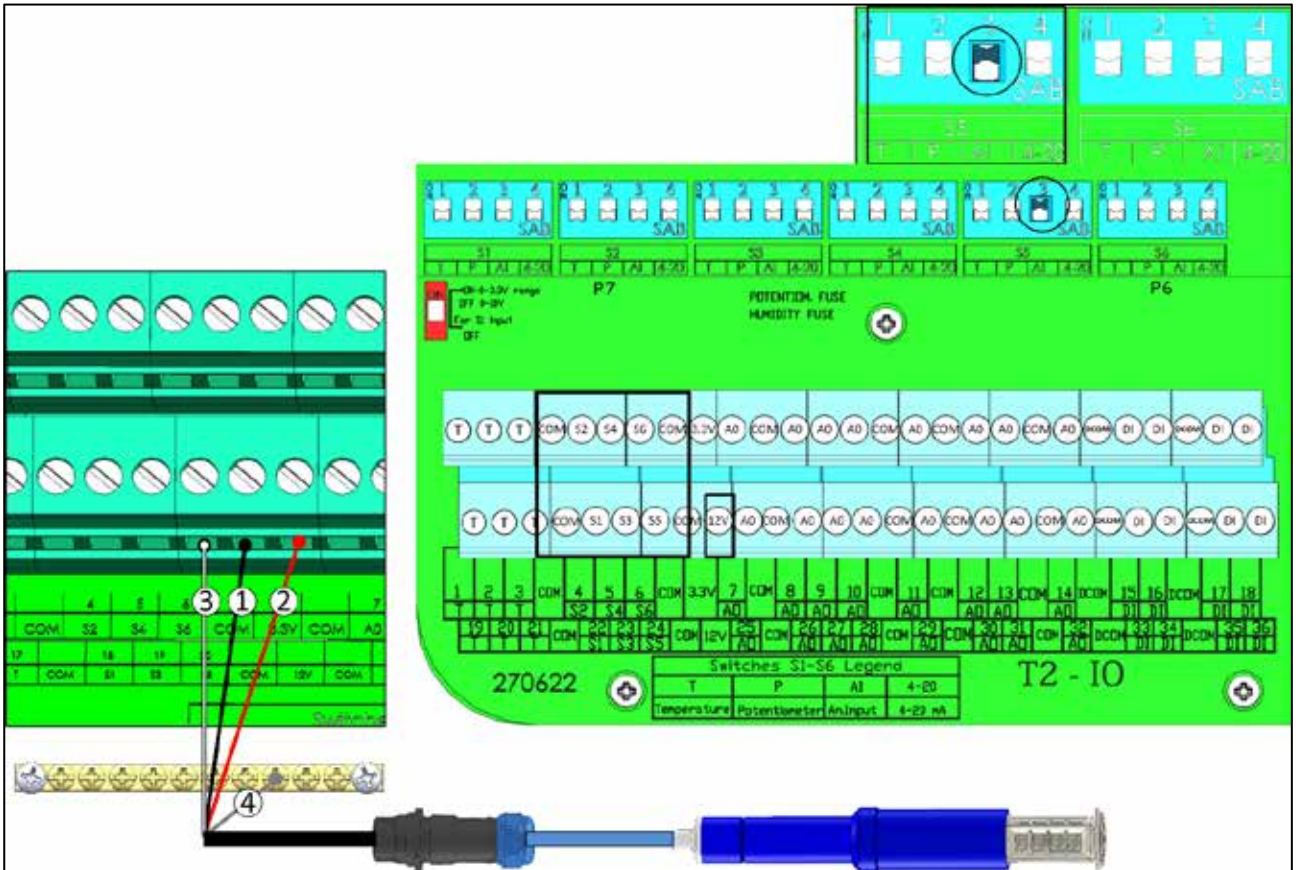

Figure 44: RHS+ Wiring

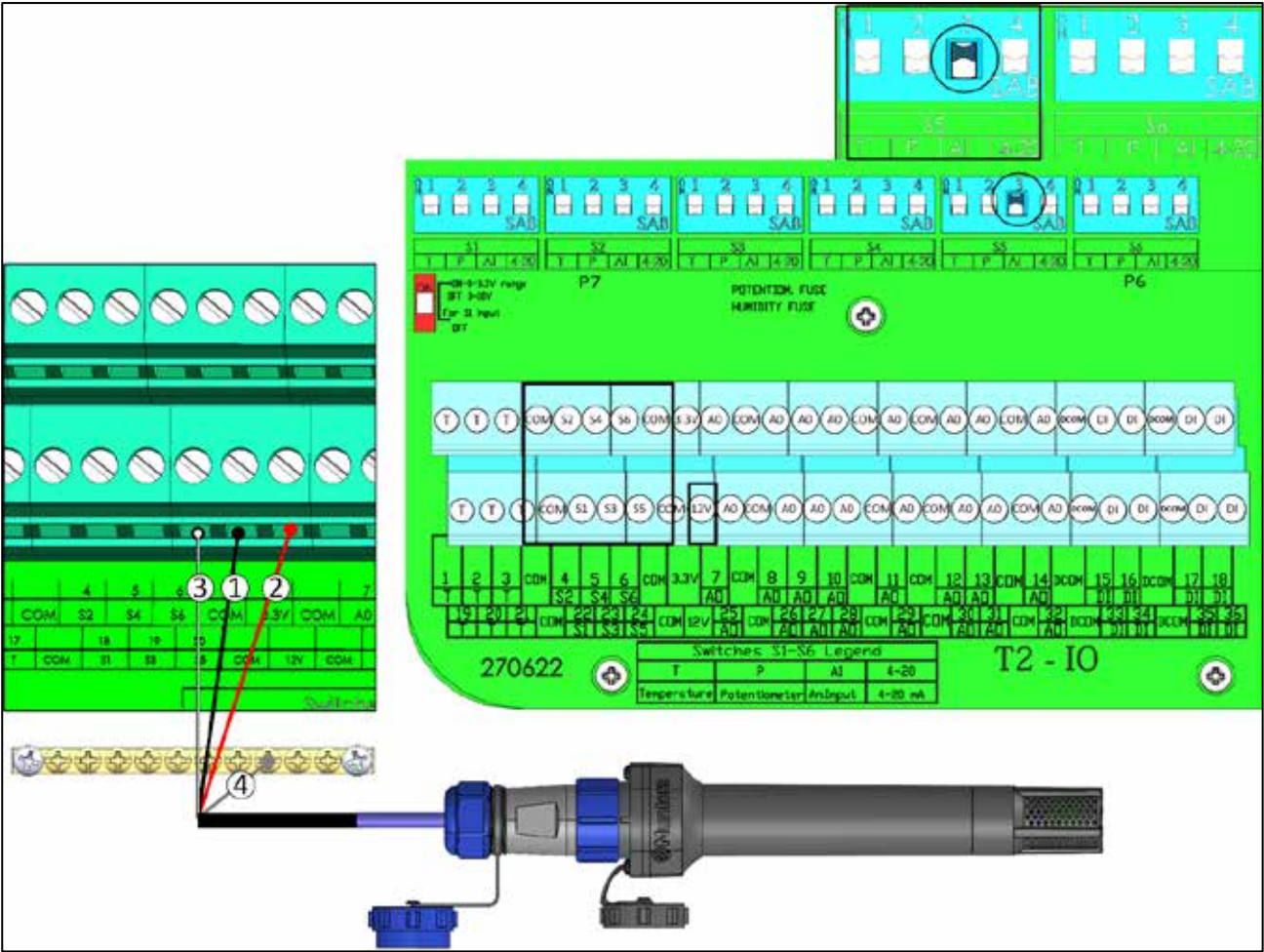

Figure 45: RHS Pro Wiring

Number	Function
1	COM port (black wire)
2	12V (red wire)
3	S port (white wire)
4	Shield wire

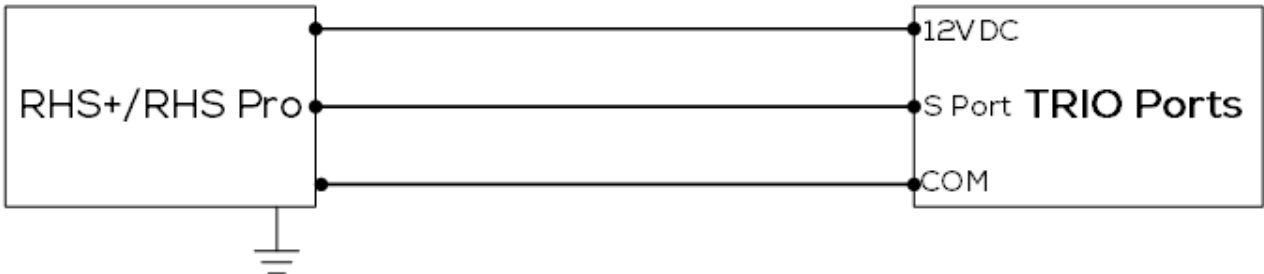

Figure 46: RHS+/Pro Sensor Wiring Schematic

- Connect each RHS+ sensor to a:
 - S port. In the corresponding dipswitch, raise dipswitch 3 (analog input).
 - COM port. Do not connect it to a DCOM port.
 - 12VDC port.
 - Grounding strip!

3.5.4.3.4 Potentiometer Wiring

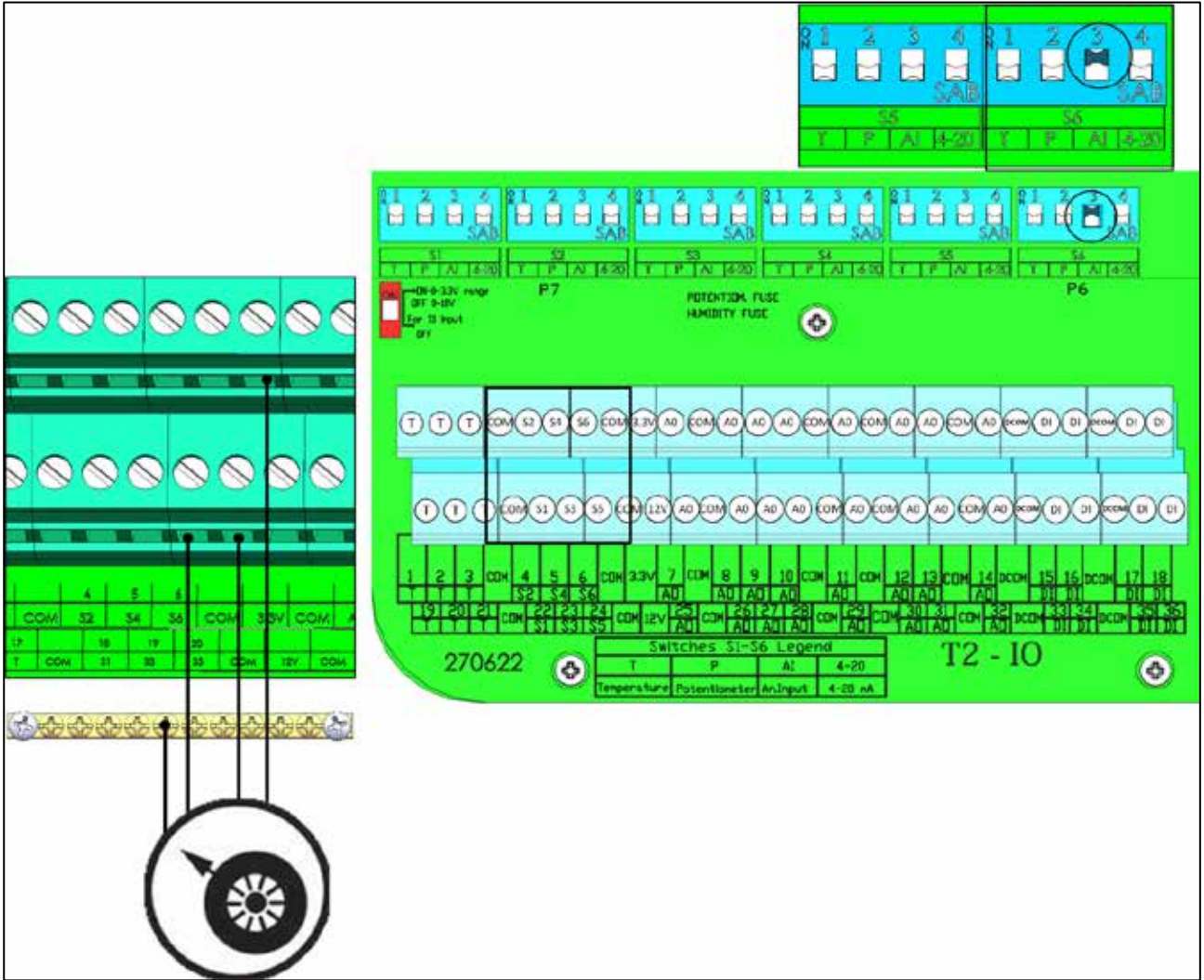

Figure 47: Potentiometer Wiring

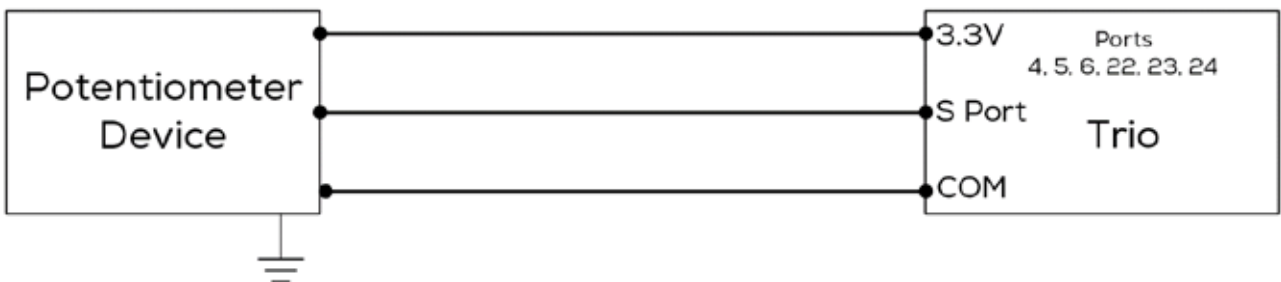

Figure 48: Potentiometer Wiring Schematic

- Connect each potentiometer to a:
 - S port. In the corresponding dipswitch, raise dipswitch 2 (potentiometer).
 - COM port. Do not connect it to a DCOM port.
 - 3.3V port.

3.5.4.3.5 Ammonia Sensor Wiring

Refer to the [Ammonia Sensor manual](#) for further information.

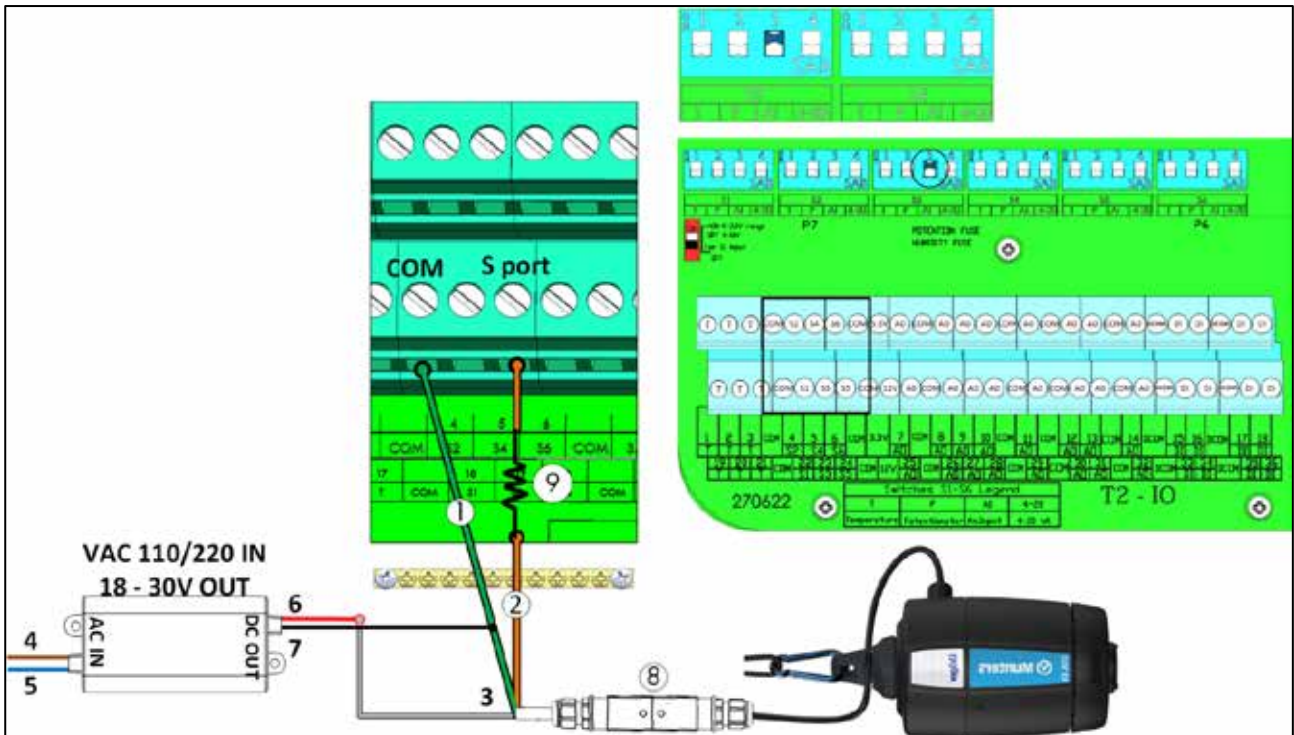

Figure 49: Board Wiring: Ammonia Sensor Wiring (WOD sensor installed)

Number	Function
1	COM port (Green wire)
2	S2 – S6 port (Brown wire)
3	White wire
4	Phase (Brown wire)
5	Neutral (Blue wire)
6	18-30VDC (Red wire)
7	COM (Black wire). Do not connect it to a DCOM port.
8	Quick Connector
9	20.3 kohm resistor (Note: The resistor comes supplied with the sensor but must be installed on-site)

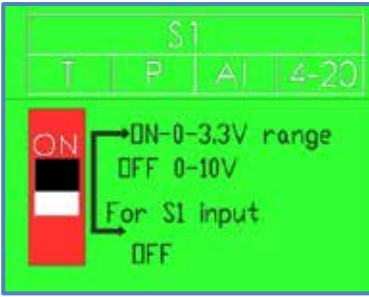

Figure 50: Ammonia Sensor Power Dipswitch

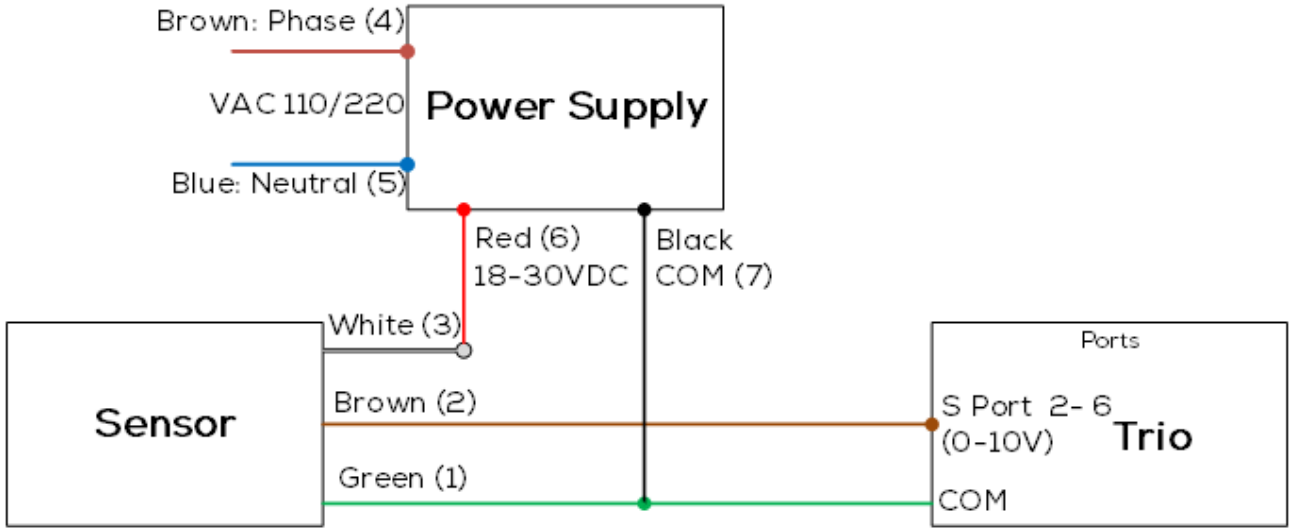

Figure 51: Ammonia Wiring Schematic

3.5.4.3.6 WOD Water Pressure Sensor Wiring

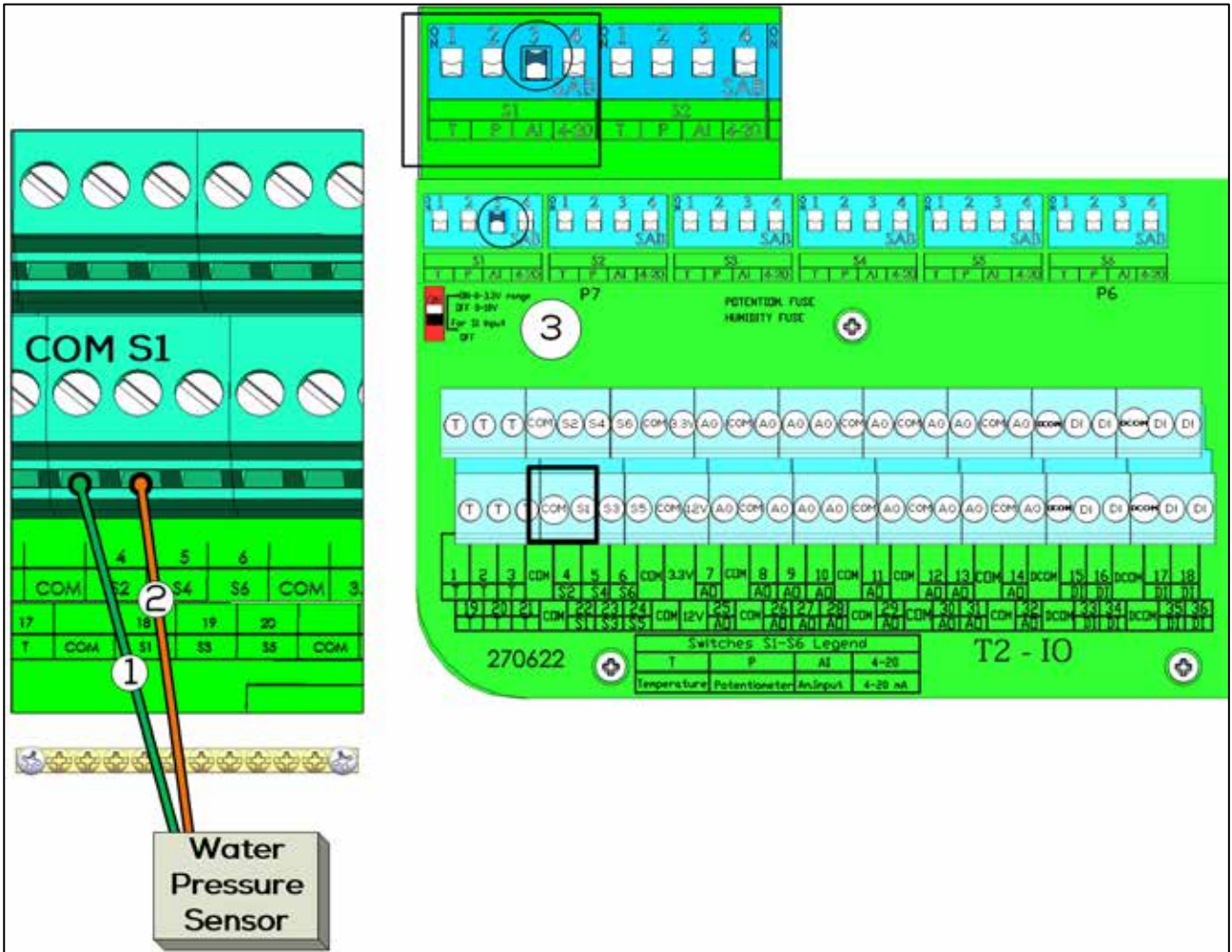

Figure 52: Board Wiring: WOD Water Pressure Sensor Wiring

Number	Function
1	COM port (Green wire)
2	S1 port (Brown wire) (The WOD Water Pressure sensor must be connected to the S1 port only).
3	Power switch



Figure 53: WOD Sensor Wiring Schematic

3.5.4.3.7 Light Sensor Wiring

Refer to the [RLS Manual](#) for more information.

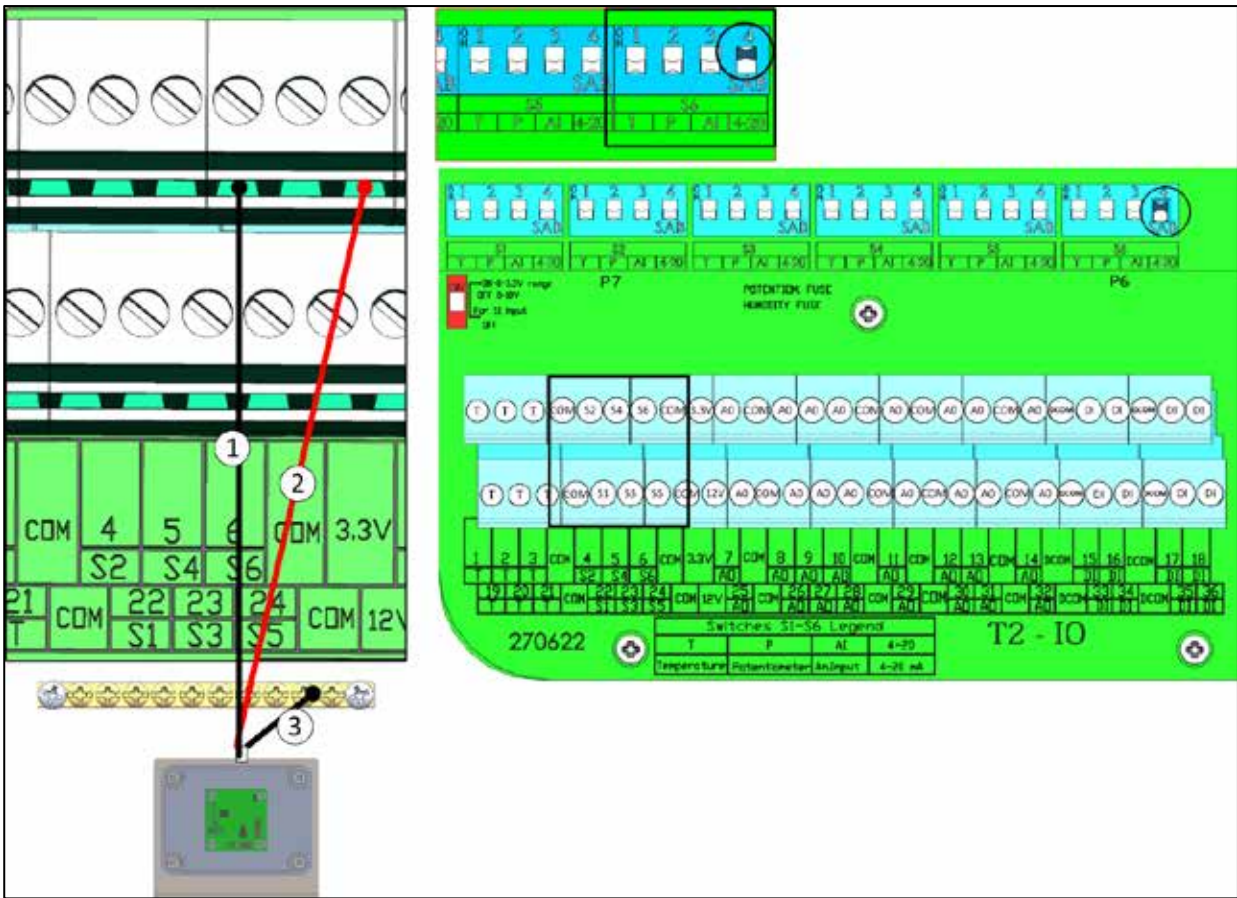

Figure 54: Light Switch Wiring

Number	Function
1	S port (black wire)
2	12V (red wire)
3	Shield wire

- Connect each RLS sensor to a:
 - S port. In the corresponding dipswitch, raise dipswitch 4 (4 -20 mA).
 - 12VDC port.
 - Grounding strip!

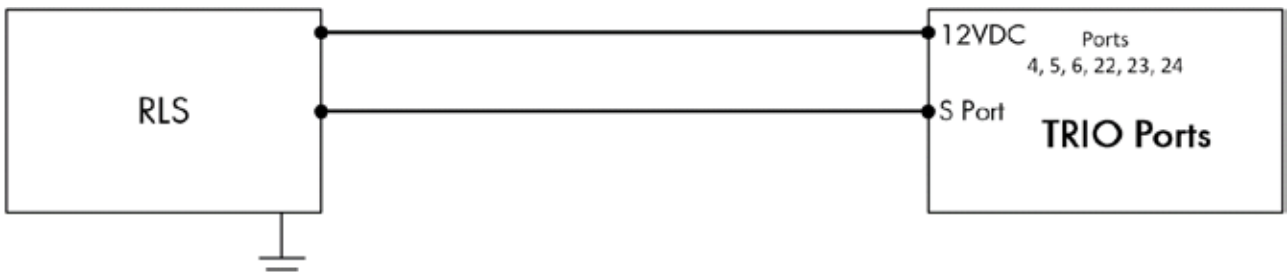

Figure 55: RLS Wiring Schematic

3.5.5 CARD WIRING

- Digital Input Devices
- Analog Input Devices
- Scale Card Devices

3.5.5.1 Digital Input Devices

Trio Rotem has a Digital Input Card (P/N: C-P3-RDIC12) with 12 inputs which are used to measure digital sensors. Each input requires an input and COM port.

- It is possible to connect the common of several sensors to the same connector. However, Munters recommends spreading the commons in an even manner.
- The Digital Input Card includes surge and lightening protection circuits and does not require external protections.

CAUTION Connect every device to an input port and a COM port.

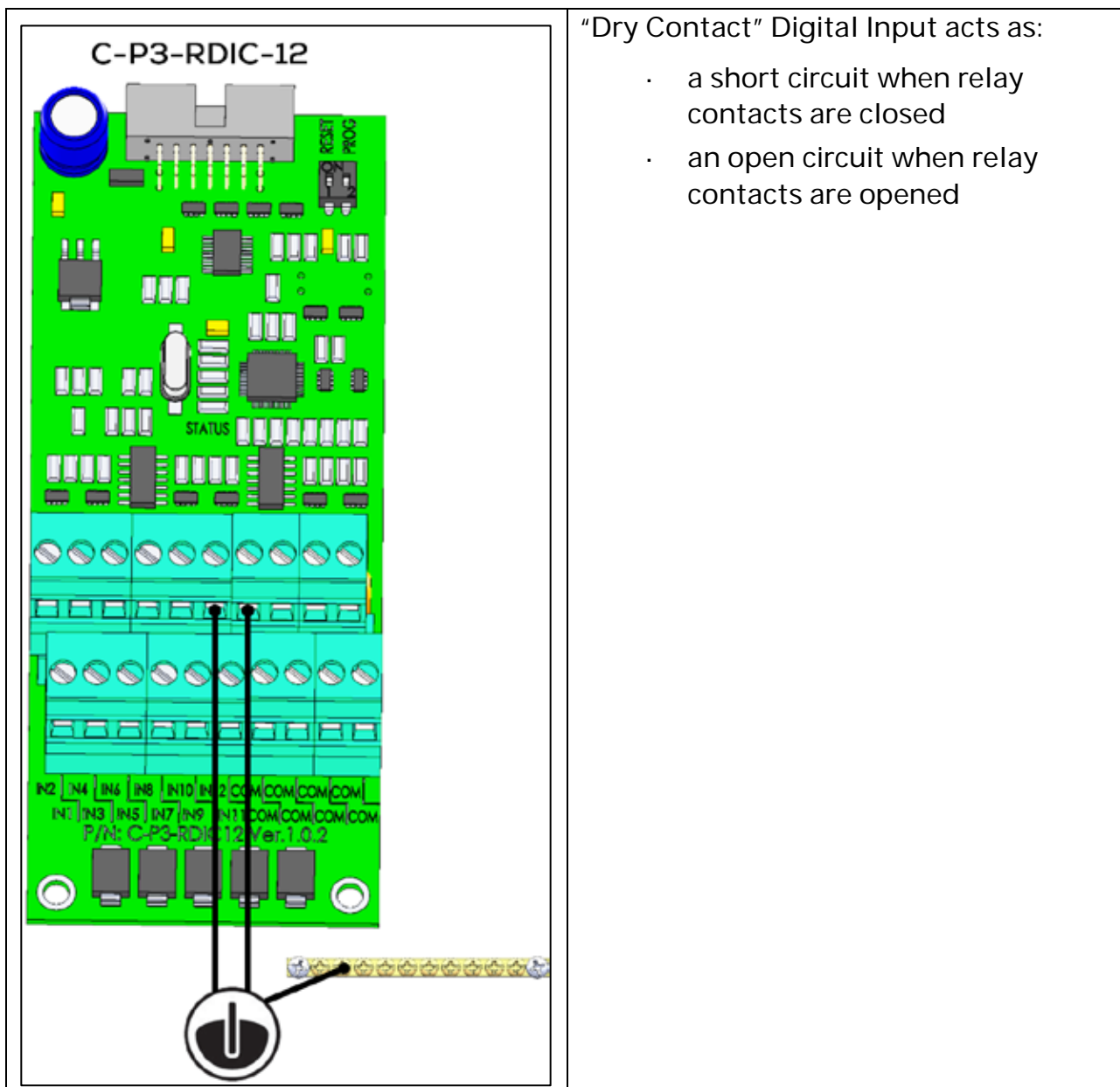

Figure 57: Digital Card Wiring

CAUTION Connect every digital output device's shield to the controller's safety ground!

3.5.5.2 Analog Input Devices

Rotem Trio Controller's analog input card (P/N: C-P3-RAIC12) supports up to 12 analog devices. The analog input cards include surge and lightning protection circuits and do not require additional external protections.

- Use 22 AWG or lower, shielded cable only!
- Connect every analog input device's shield to the controller's safety ground!
- Every COM input is correct and more than one sensor can be connected to a COM input.

- Analog Card DIP Switches
- CO2 Sensor Wiring
- Temperature Sensor Wiring
- Humidity Sensor Wiring
- Potentiometer Device Wiring
- Ammonia Sensor Wiring
- Light Sensor Wiring

3.5.5.2.1 Analog Card DIP Switches

The RAIC-12 has the following ports:

- T1 – T8: Eight dedicated temperature sensor inputs
- IN1 – IN4: Four input ports defined using dip switches
- Four COM ports
- +12V: Two dedicated humidity sensor voltage (12V) ports
- 3.3V: Two dedicated potentiometer voltage (3.3V) ports

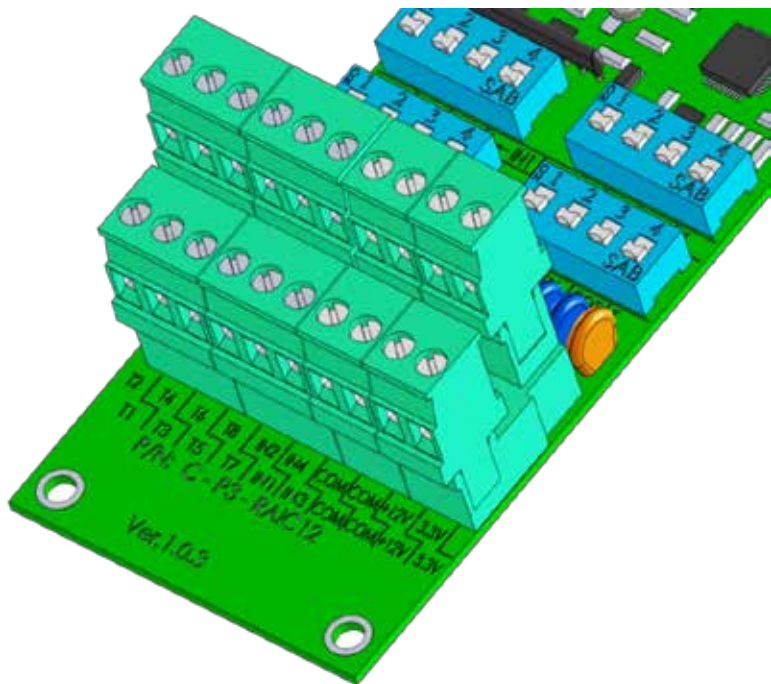

Figure 58: Analog Input Card Ports

To configure the IN1 – IN4 ports move one dip switch to ON in each set of ports.

CAUTION Leaving all switches in the Off position or placing more than one switch in the On position in a set nullifies those functions!!

- DIP Switch 1: 4 – 20 mA (CO2 and light sensors)
- DIP Switch 2: 0 – 5V (humidity)
- DIP Switch 3: Potentiometer and wind direction sensors
- DIP Switch 4: Temperature sensor

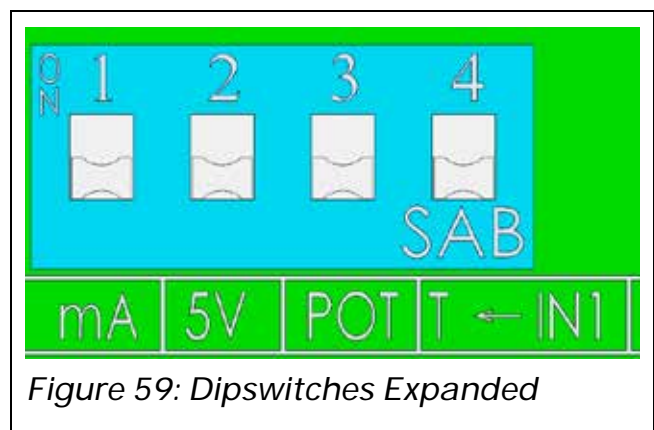

Figure 59: Dipswitches Expanded

3.5.5.2.2 CO2 Sensor Wiring

Refer to the [CO2 Sensor Manual](#) for details on installing this unit.

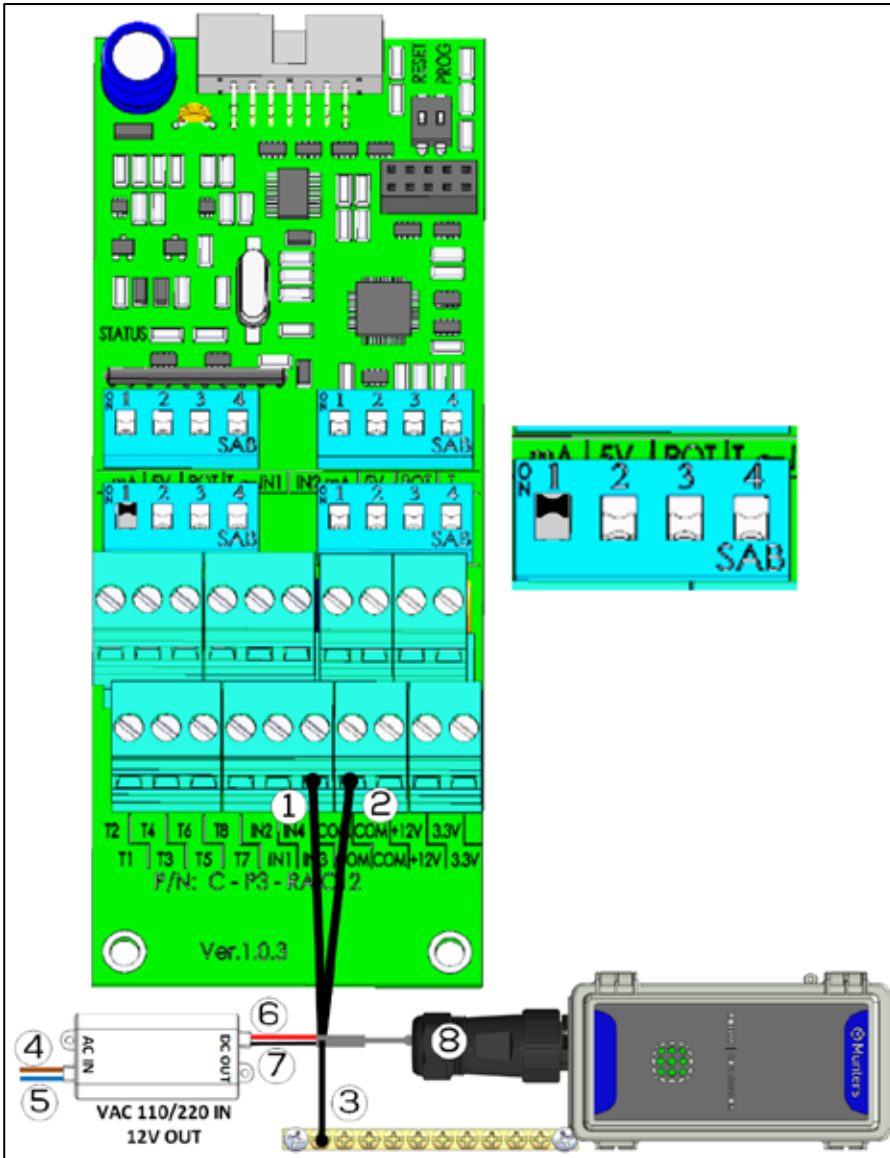

Figure 60: Trio- CO2 Sensor Wiring (P/N: 913-03-XXXXX)

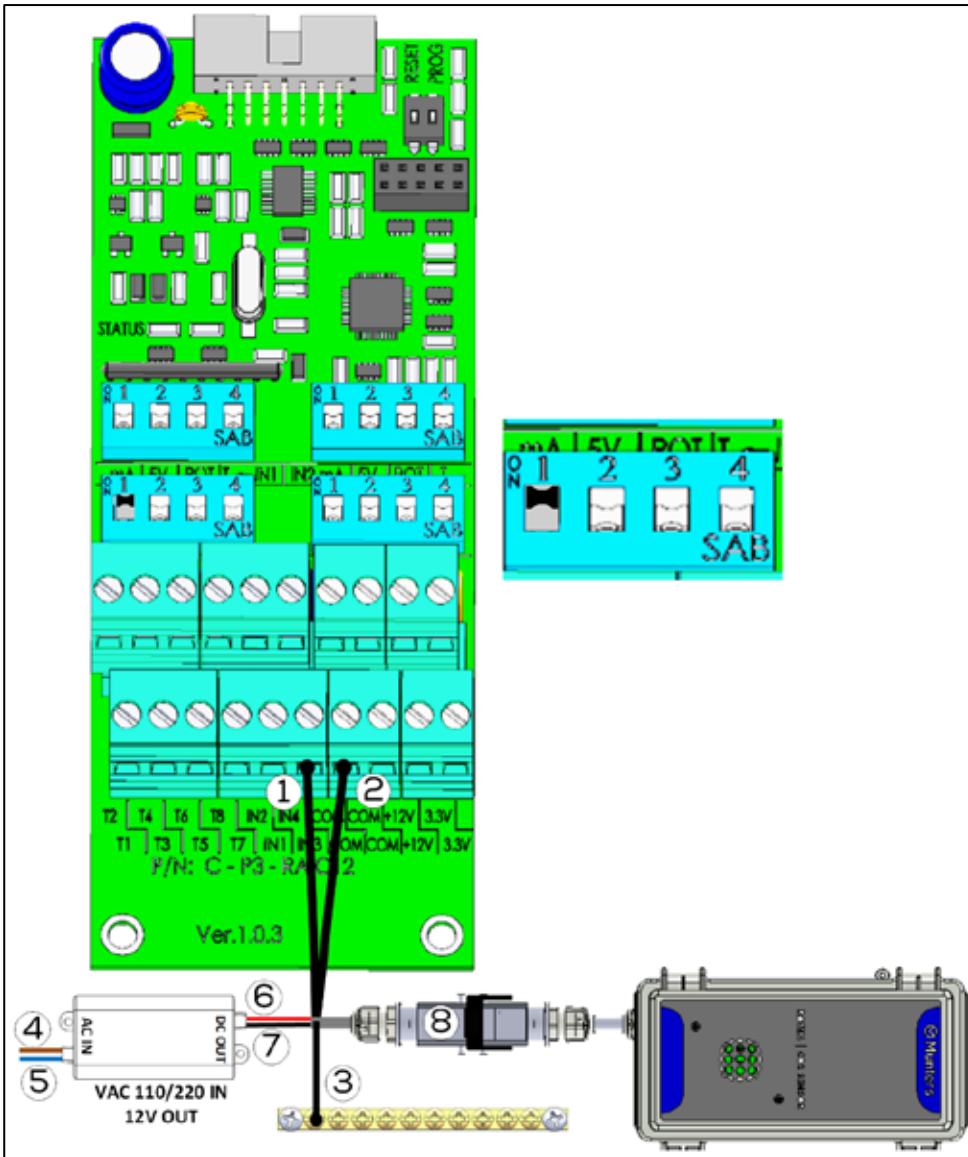

Figure 61: CO2 Sensor Wiring (P/N: 913-01-XXXXX)

1. Connect each sensor to an input and COM port.
2. IN1 – IN4: Turn DIP Switch 1 on each set as required.

Number	Function	Number	Function
1	IN port	5	Blue wire: neutral
2	COM port	6	Red wire: +12VDC
3	Shield wire	7	Black wire: -12VDC
4	Brown wire: phase	8	Connector

3.5.5.2.3 Temperature Sensor Wiring

An RTS Sensor can be connected to the analog input card via a dedicated temperature sensor port (Figure 58) or a data input port (Figure 59).

- Connect each RTS sensor to a T port and a COM port.

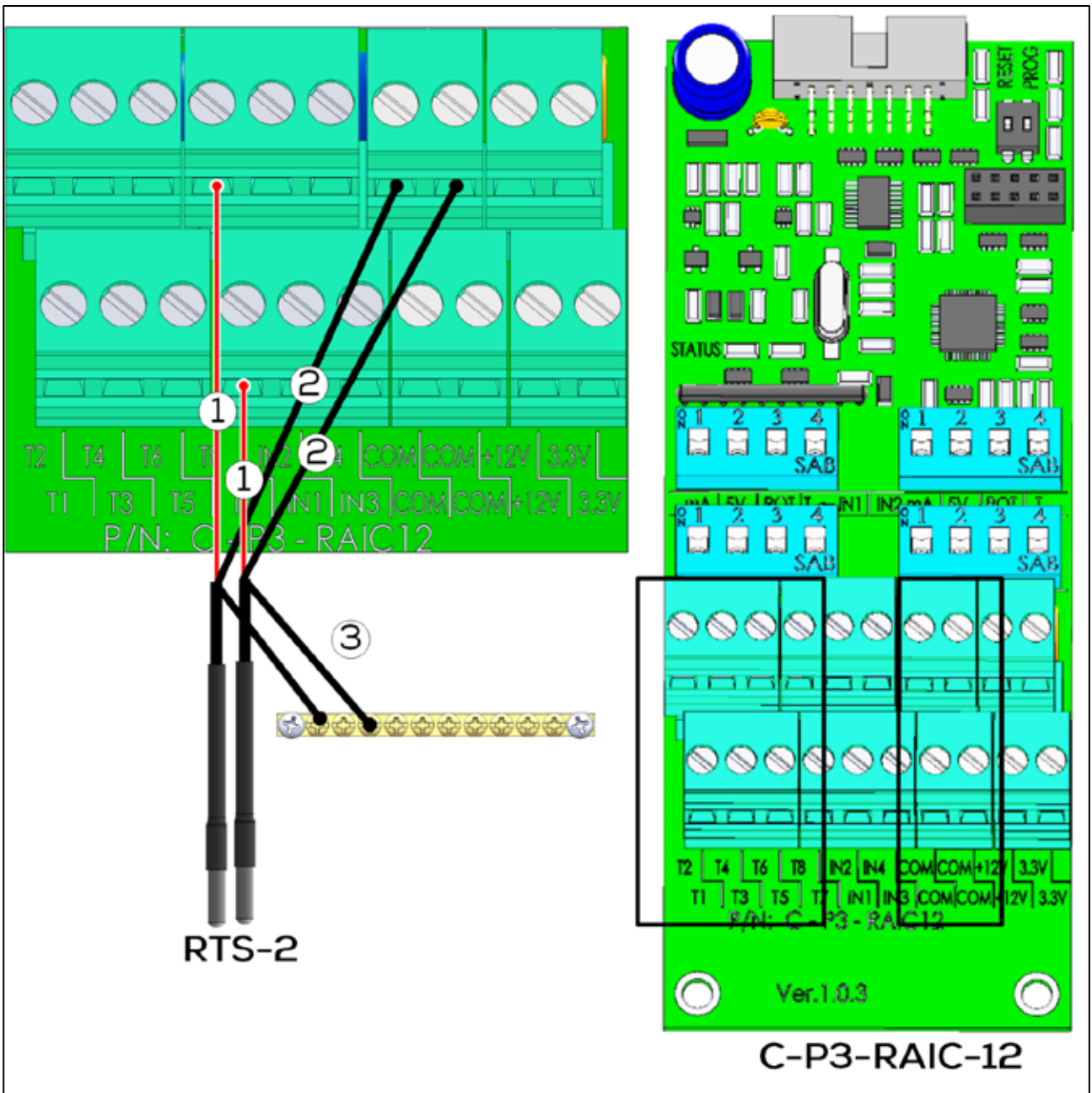

Figure 62: Card Wiring: RTS Wiring

Number	Function
1	COM port (black wire)
2	T port (red wire)
3	Ground wire

1. Connect each RTS sensor to a N port and a COM port.
2. IN1 – IN4: Turn DIP Switch 4 on each set as required.

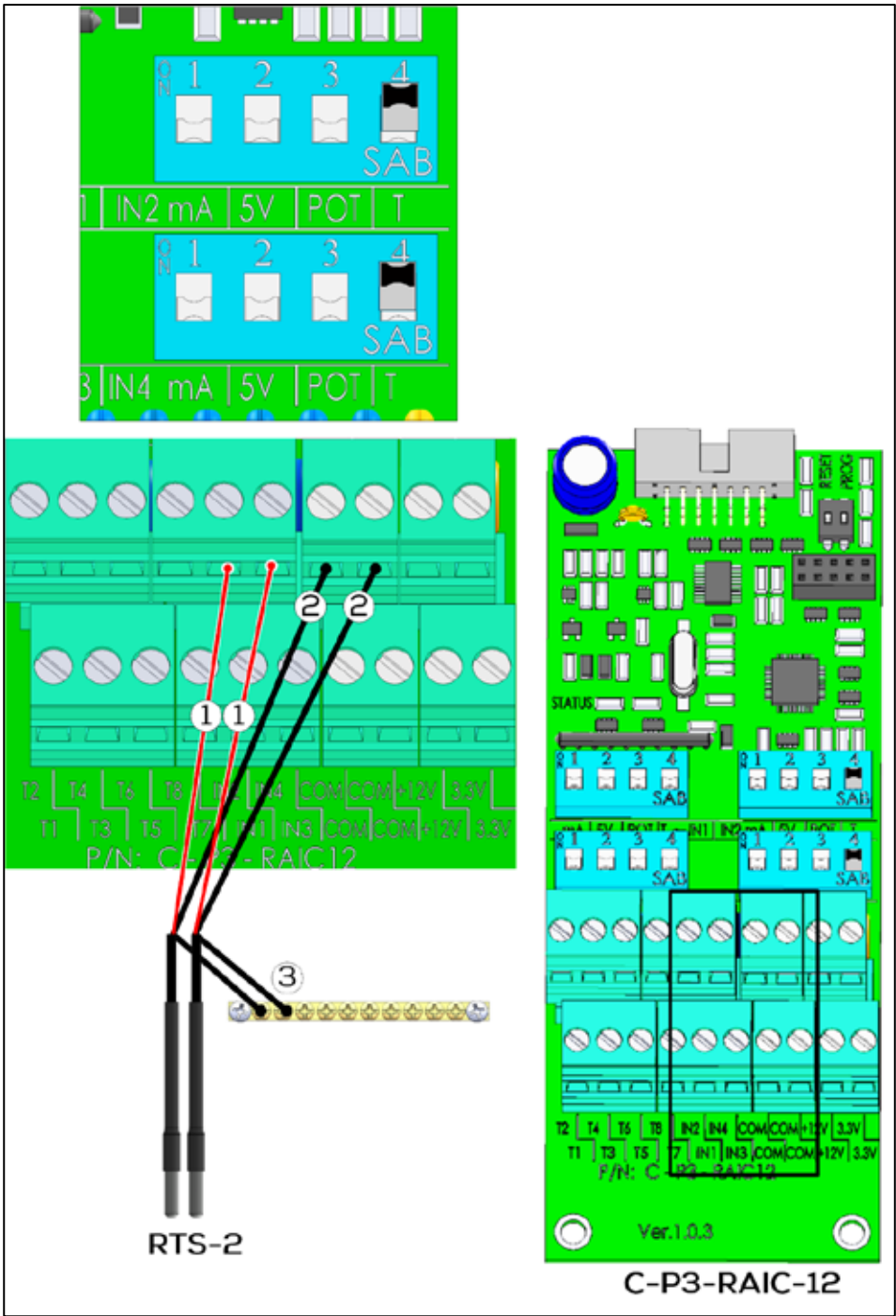

Figure 63: Card Wiring: RTS IN Port Wiring

Number	Function
1	IN port (red wire)
2	COM port (black wire)
3	Shield wire

3.5.5.2.4 Humidity Sensor Wiring

1. Connect each humidity sensor to input, a COM, and +12V port.
2. IN1 – IN4: Turn DIP Switch 2 on each set as required.

Figure 60 shows an example of a humidity sensor wiring setup.

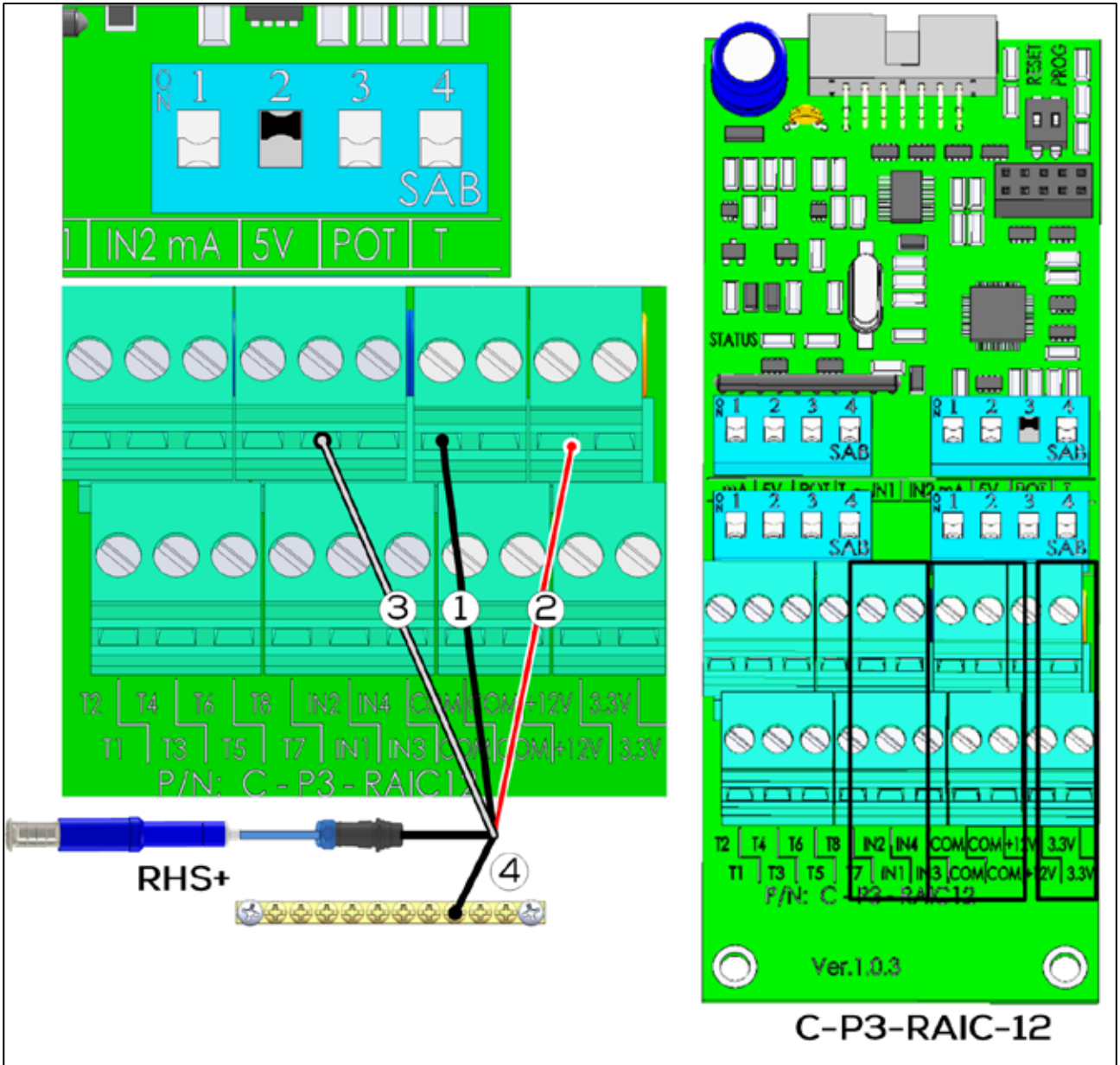

Figure 64: RHS+ Humidity Sensor Wiring

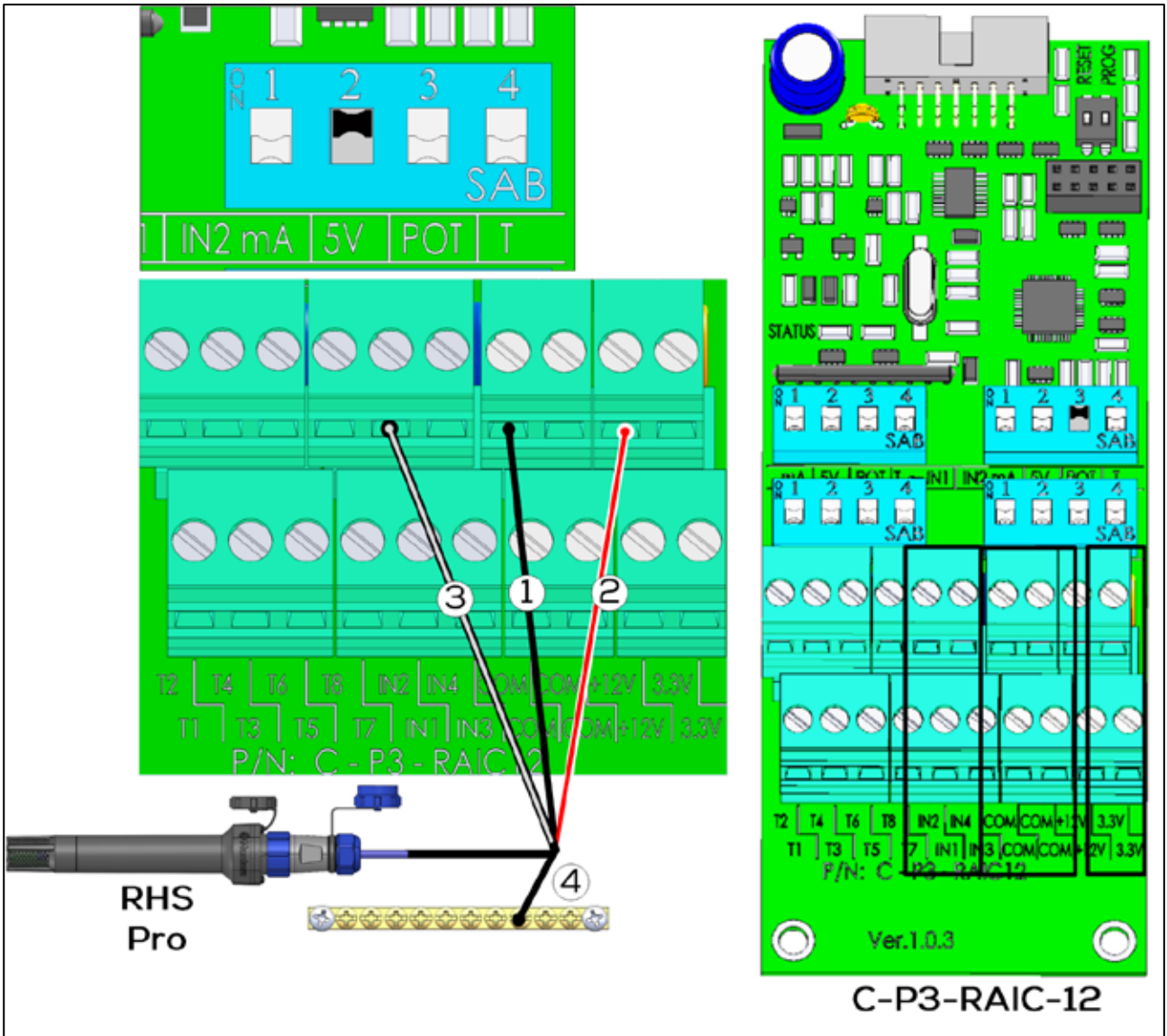

Figure 65: RHS Pro Humidity Sensor Wiring

Number	Function
1	COM port (black wire)
2	12V (red wire)
3	IN port (white wire)
4	Shield wire

3.5.5.2.5 Potentiometer Device Wiring

1. Connect each potentiometer (10 - 20 KOhm) to an input, a COM, and 3.3V port.
2. IN1 – IN4: Turn DIP Switch 3 (POT) on each set as required.

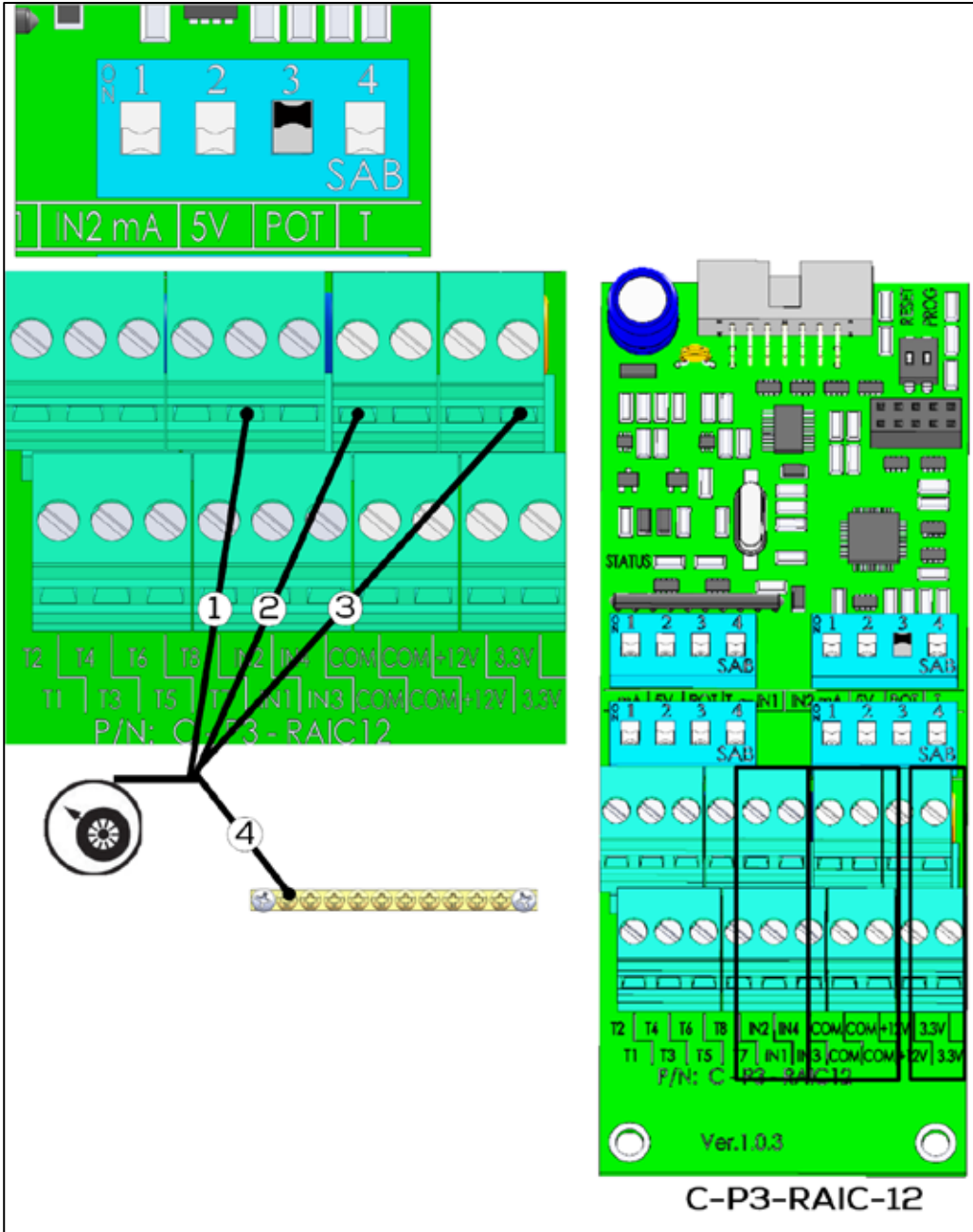

Figure 66: Potentiometer Wiring

Number	Function
1	In port
2	COM port
3	3.3 port
4	Shield wire

3.5.5.2.6 Ammonia Sensor Wiring

Refer to the [Ammonia Sensor manual](#) for further information.

- On the Analog Input Card, set the corresponding dipswitch to the 5V position (dipswitch 2).

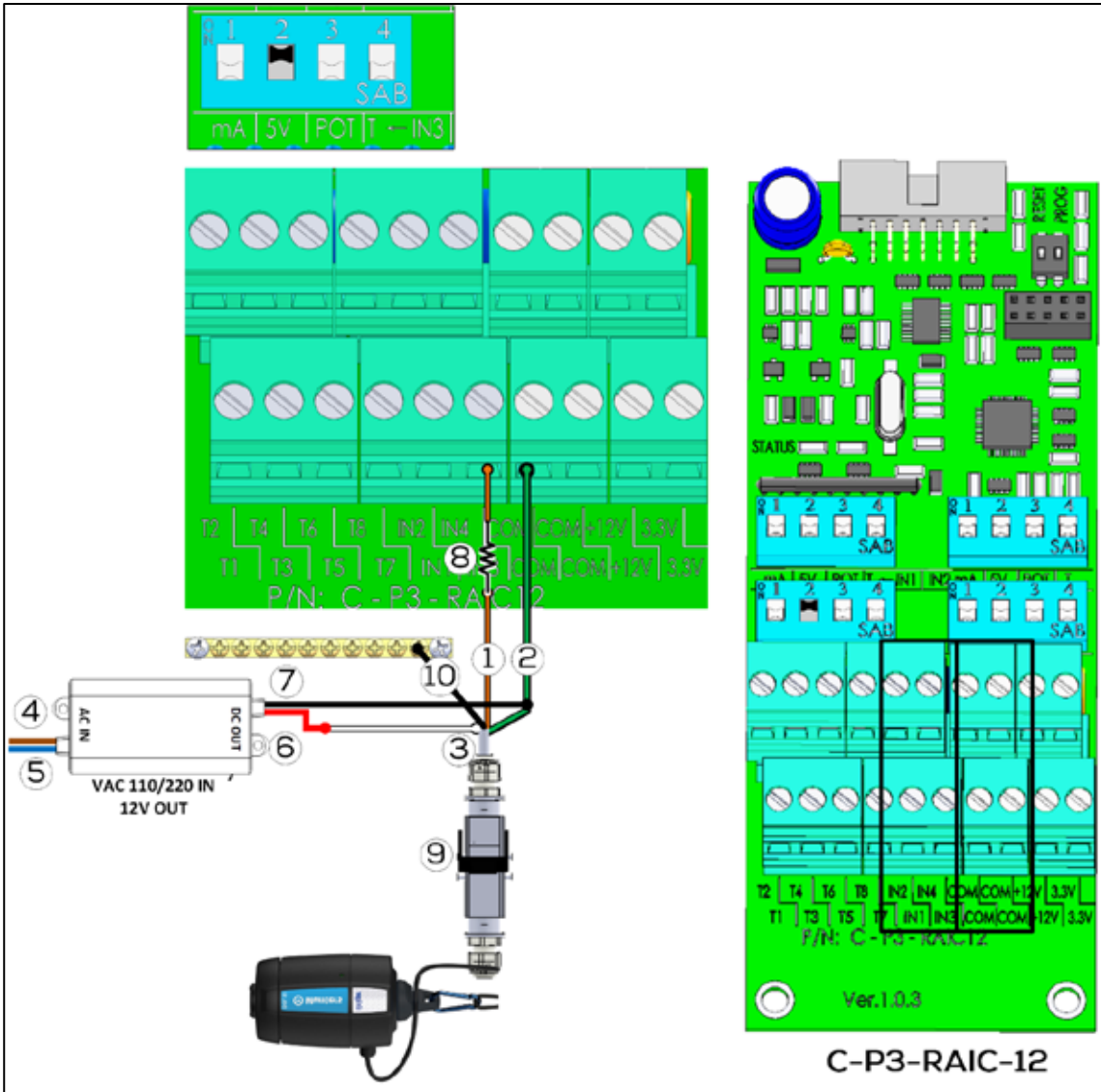

Figure 67: Card Wiring: Ammonia Sensor Wiring

Number	Function	Number	Function
1	IN port (Brown wire)	6	18-30VDC (Red wire)
2	COM port (Green wire)	7	COM (Black wire)
3	White wire	8	20.3 kohm resistor (Note: The resistor comes supplied with the sensor but must be installed on-site)
4	Phase (Brown wire)	9	Connector
5	Neutral (Blue wire)	10	Grounding

3.5.5.2.7 Light Sensor Wiring

Refer to the [RLS Manual](#) for more information.

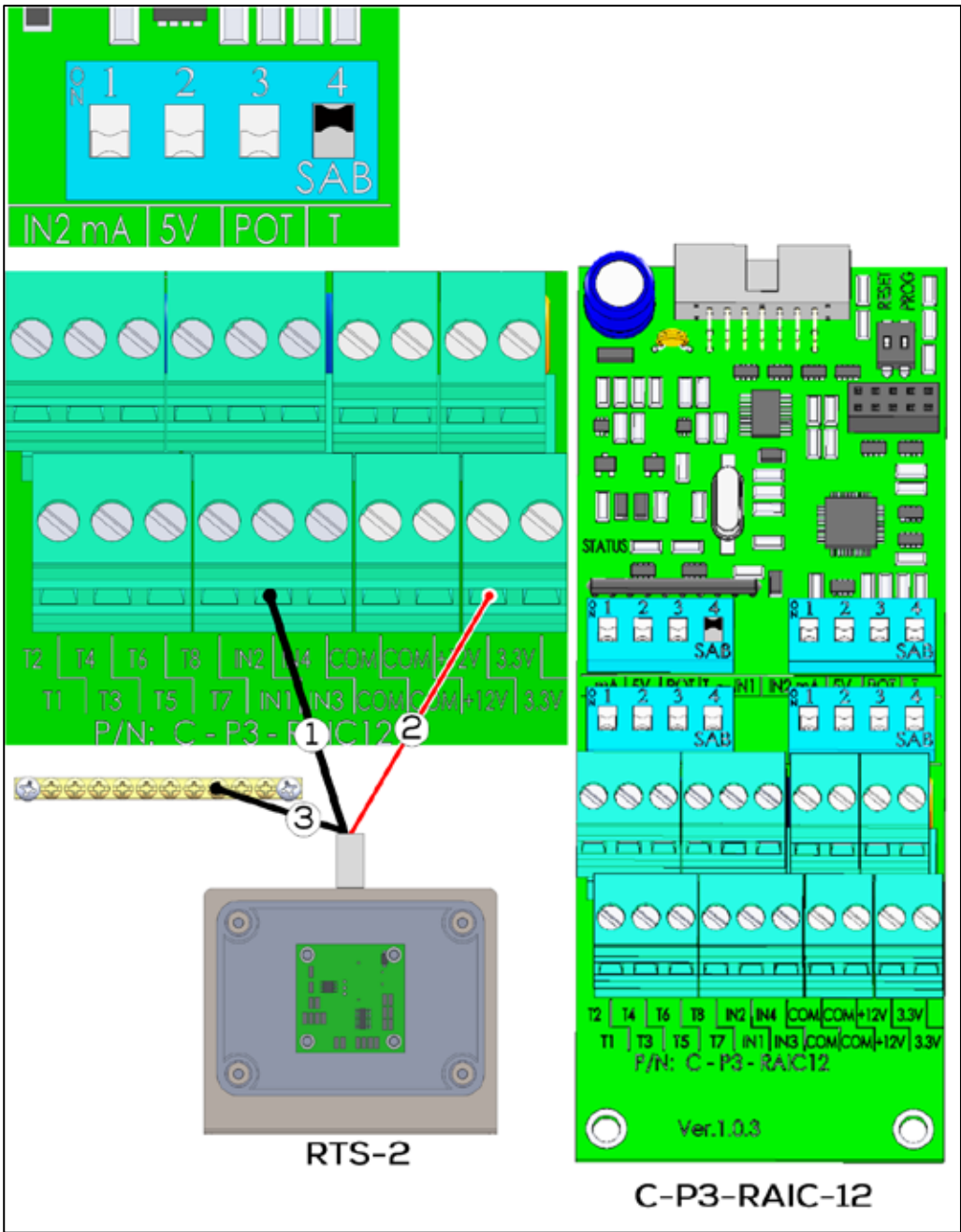

Figure 68: Card Wiring: Light Sensor Wiring

Number	Function
1	IN port (black wire)
2	12V (red wire)
3	Shield wire

3.5.5.3 Scale Card Devices

- Bird Scale Wiring
- Silo Wiring

3.5.5.3.1 Bird Scale Wiring

If you install a scale card, perform a cold start. Refer to the user manual.

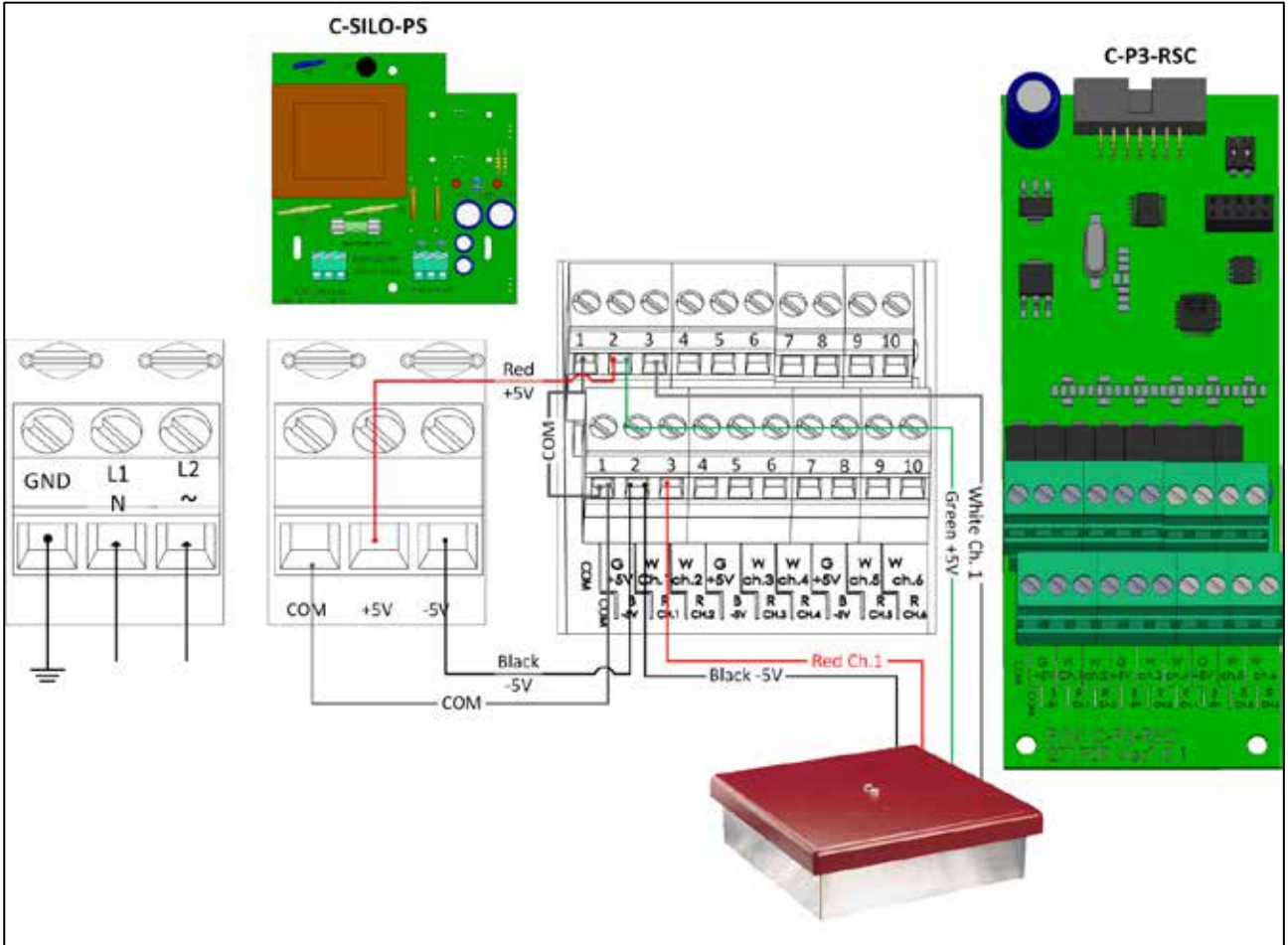

Figure 69: Scale Card wiring to Power Supply and Bird Scale

3.5.5.3.2 Silo Wiring

Wire the TRIO to an RJB-6 Junction Box and power supply. For details on how to wire the Junction Box to the load cells, refer to the RJB manual.

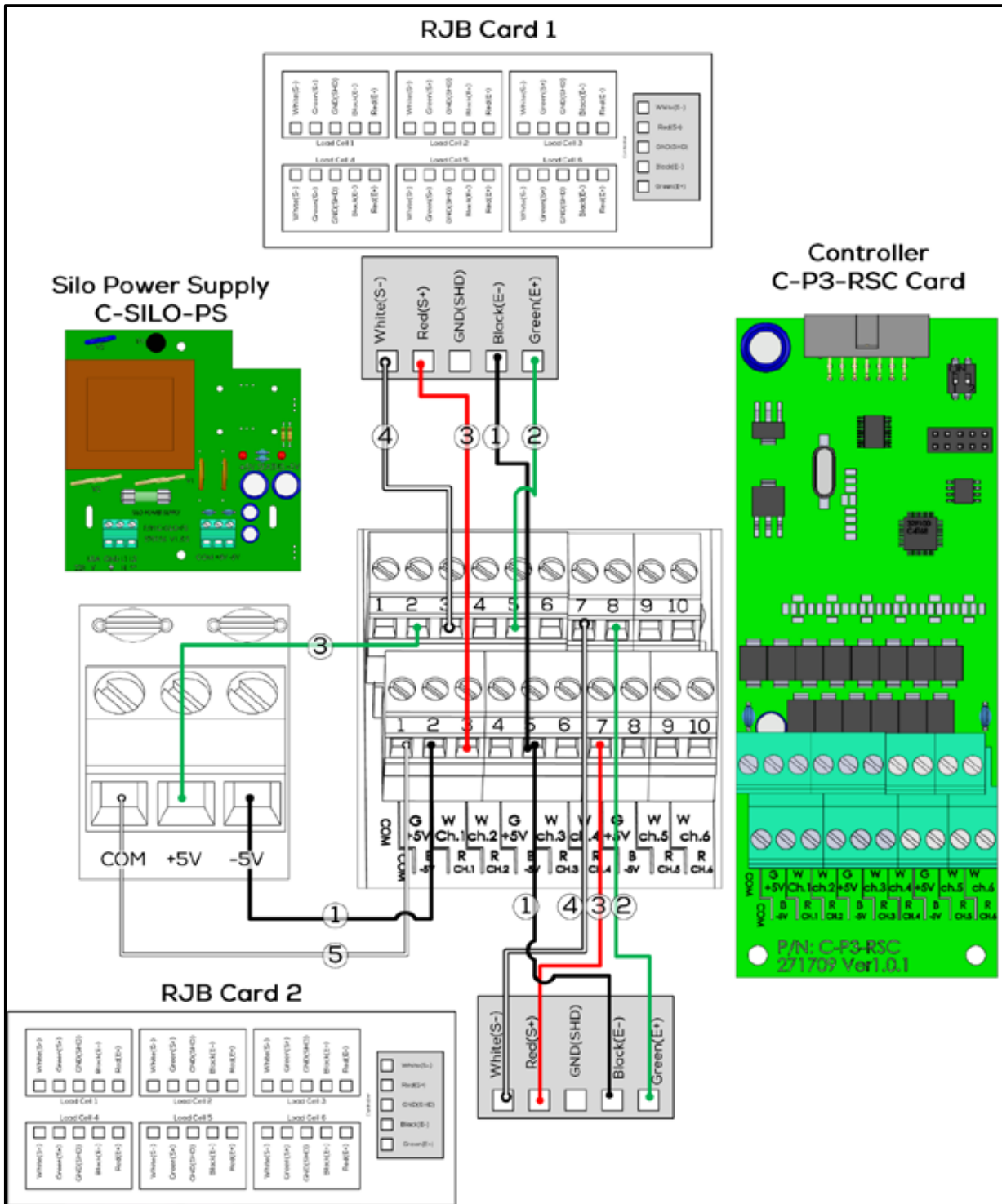

Figure 70: Scale Card wiring to Power Supply and RJB

RJB Wire	RSC Ports	RJB Wire	RSC Ports
Green	2, 5, 8 (Upper)	White	3, 4, 6, 7, 9, 10 (Upper)
Black	2, 5, 8 (Lower)	Red	3, 4, 6, 7, 9, 10 (Lower)

Note: Connect each RJB white and red wire to matching ports. For example White Ch.1 and Red Ch.1

3.5.6 TRIO RPS

Trio RPS serves as a second static pressure sensor for the Rotem Trio Controller. The following section details the installation. Trio supports up to two static pressure sensors; one built in and one external. Install the RPS in the second room.

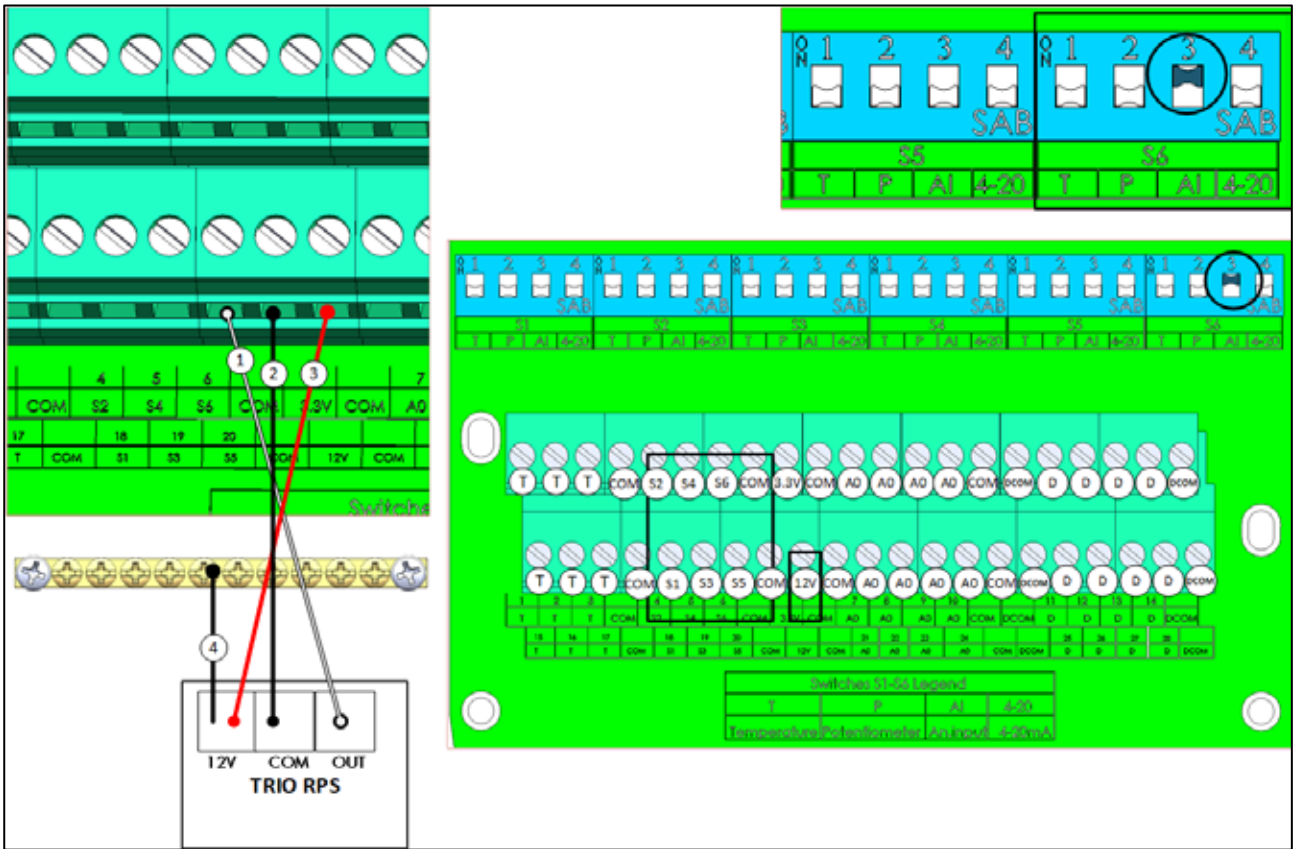

Figure 71: RPS Wiring

Number	Function
1	S port. Raise the corresponding S3 dipswitch.
2	COM port
3	12V
4	Shield wire

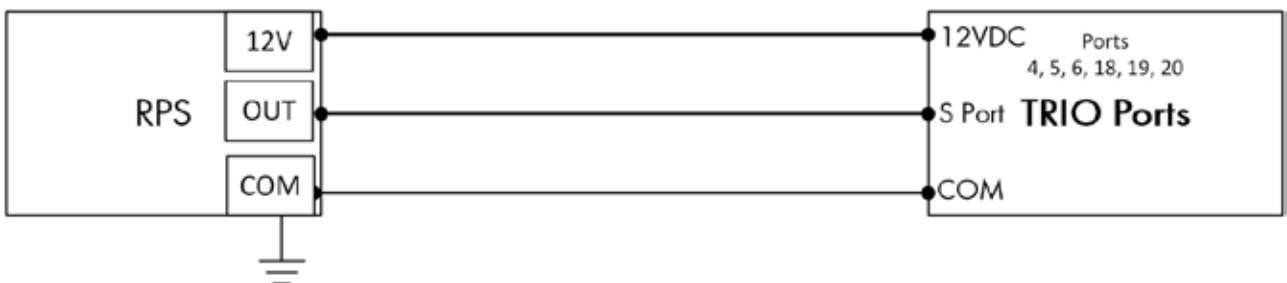

Figure 72: RPS Wiring Schematic

NOTE After installing the RPS, no Cold Start is required.

3.5.7 RSU WIRING

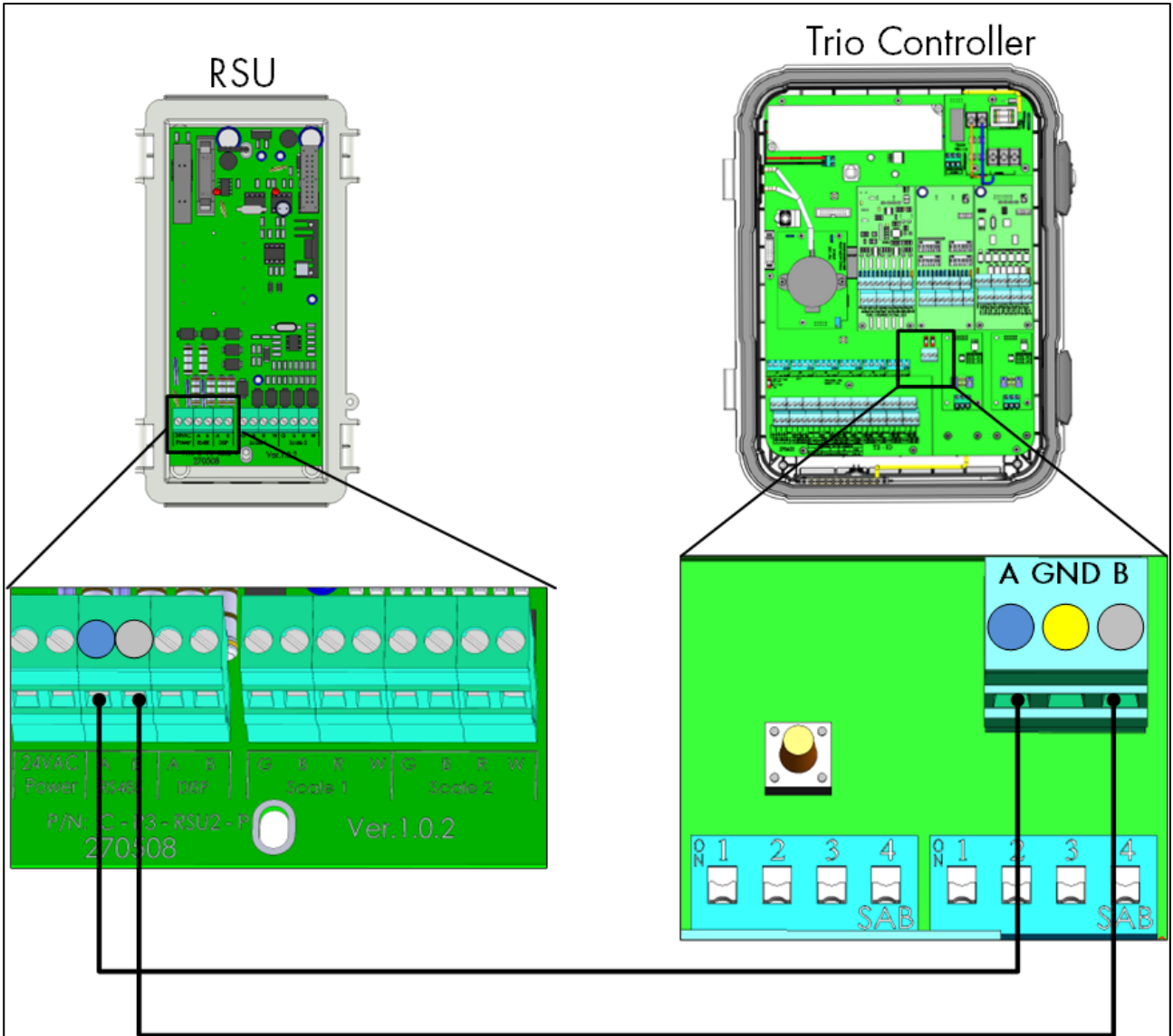

Figure 73: Trio – RSU Wiring

3.6 Termination

Termination, installing or enabling 120-ohm termination resistors at the beginning and end units of a chain, ensures reliable communication in RS-485 infrastructures.

Termination is recommended when the distance between Trio and the final device in the chain is more than 50 meters/165 feet. Trio and Trio Expansion come with a switch to enable termination; an external resistor must be installed on the RSU communication card. Termination may not be required in shorter installations.

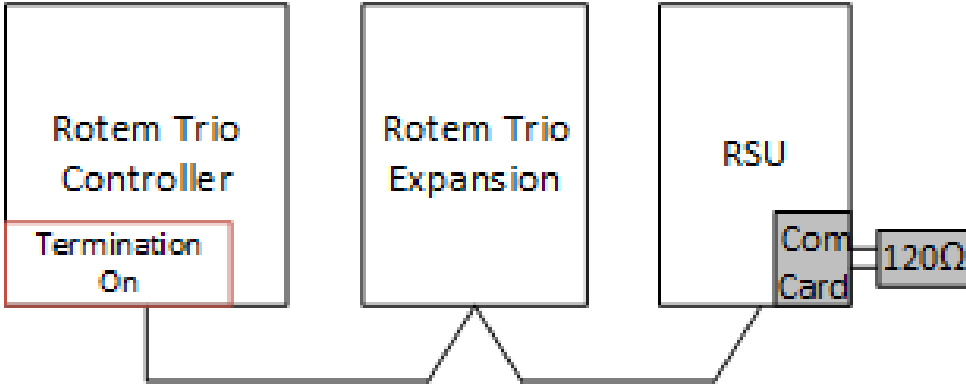

Figure 74: Termination Sample Topology

3.7 Pressure Sensor Hoses

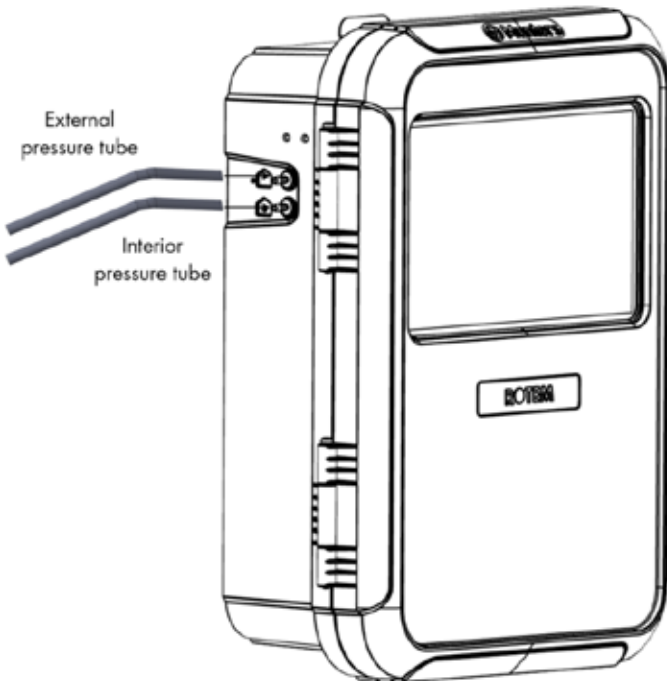

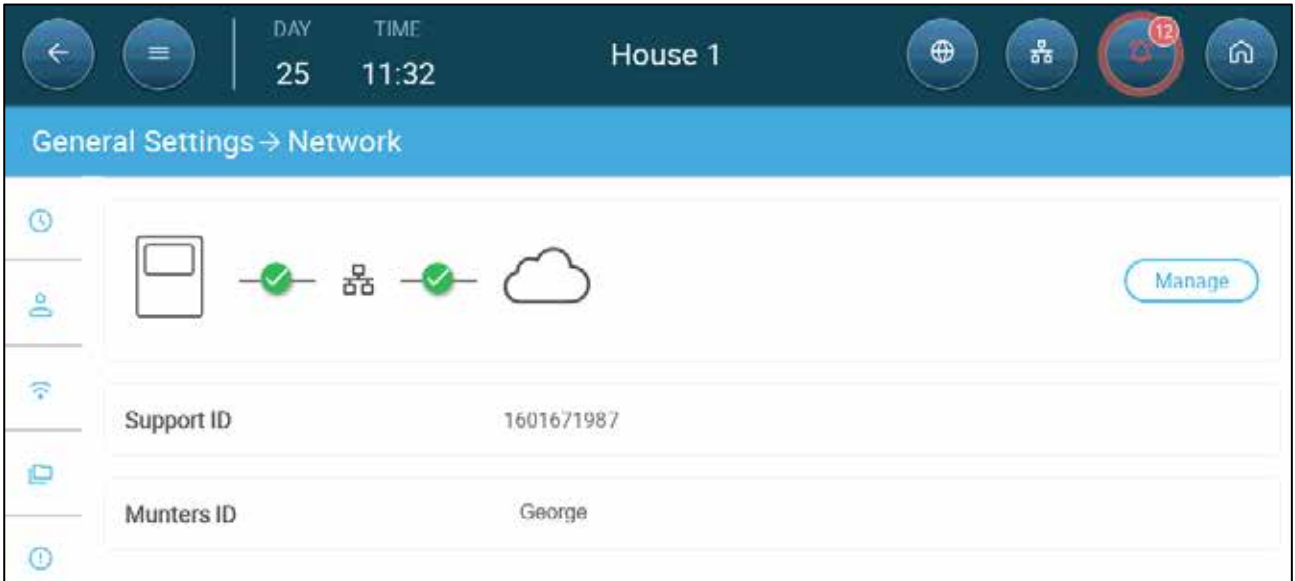

Figure 75: Static Pressure Hoses

3.8 Tech Support/Wi-Fi

To view your unit's network information go to System > General Settings > Network . You will need this information when speaking with technical support.



- Click Manage.

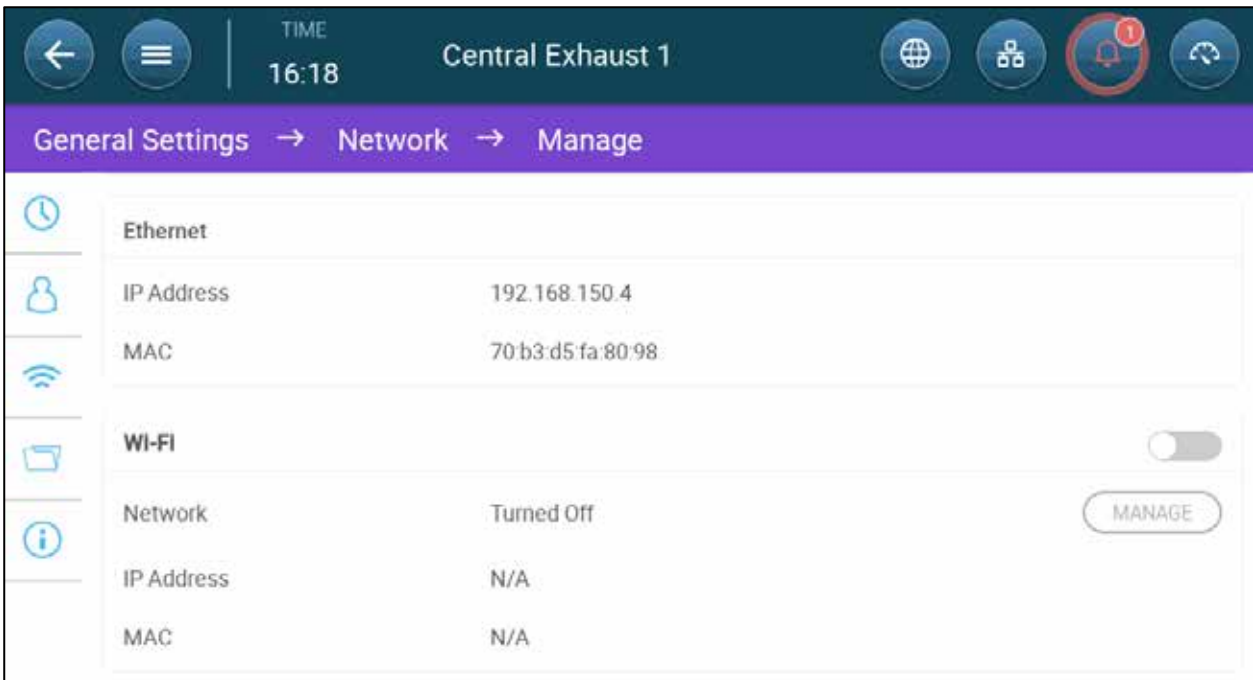

- Ethernet fields are read-only information.
- Enable Wi-Fi if required.





4 Specifications

4.1 Rotem Trio Expansion 70 Specifications

Description	Specification
Input Power Voltage	<ul style="list-style-type: none"> 100 - 240 VAC 1.0 A, 50/60 Hz
Relay Rating	15A
Maximum Relay Load	6.3 Amp. Up to 70% of the relays can operate at any given time, at 240 Volts.
Normally Open Relays	<ul style="list-style-type: none"> Non Fused 70% of relays can operate simultaneously (maximum) 200 - 240 VAC max load: 2HP (6.25A during continual operation, up to 30A at startup) 100 -130 VAC max load: 1HP (5.8A during continual operation, up to 30A at startup)
Normally Close Relays	<ul style="list-style-type: none"> Non Fused 70% of relays can operate simultaneously (maximum) 200 - 240 VAC max load: 1HP (3A during continual operation, up to 20 Amp at startup) 100 -130 VAC max load: 0.5HP (2.9A during continual operation, up to 20A at startup)
CAUTION Switching loads over 10A reduces a relay's life span (from 100,000 operations to ~10,000 operations).	
Operating Temperature Range	32° to 125° F (0° to +50° C)
Dimensions (H x W x D)	26 x 19 x 9.7 in (665 x 484 x 247 mm)
Environmental Specifications	<ul style="list-style-type: none"> Altitude: -400 m to 2000 m Relative Humidity: 20% - 90% Main supply voltage fluctuation up to +10 - 20%

Description	Specification
	<ul style="list-style-type: none"> · Overvoltage category II · PD: 2
Enclosure	<ul style="list-style-type: none"> · IP: 52 · Indoor use only
Fuses	Fuse F1 and F4 on PS card: 5A, 250V
Power Cable	<ul style="list-style-type: none"> · Copper, 3-wires Phase, Neutral, Ground, 18 AWG minimum · 600V insulation

4.2 Rotem Trio Controller Specifications

Description	Specification
Input Power Voltage	<ul style="list-style-type: none"> · 100 – 240 VAC · 50/60 Hz
Input AC Power	0.75A
Analog Inputs	0 – 3.3 Volts
Analog Output	0 - 10 Volts; maximum load: 20 mA
Digital Inputs	Dry contact
Communication	LAN – Standard 10/100 BaseT Refer to Appendix D: IT Setup, page 187 for details
Operating and Storage Temperature Range	-10° to +50° C (+14° to +125° F)
Environmental Specifications	<ul style="list-style-type: none"> · Altitude: -400 m to 2000 m · Relative Humidity: 20% - 70% · Main supply voltage fluctuation up to 5% · Overvoltage category II · PD: 2
Enclosure	<ul style="list-style-type: none"> · IP: 52 · Indoor use only
Dimensions (H/W/D)	16 x 13 x 5.6 inches (403 x 324 x 141 mm)
Fuses	Fuse F2 on PS card: 3.15A, 250V
Certification	   

4.3 Electrical Notes

- **Disconnection device/overcurrent protection:** The disconnect device in the building installation must be provided according to national regulations and using a certified 2-pole circuit breaker rated 10A, certified in accordance with the IEC standard 60947-2 (in the US and Canada use a Listed Branch Circuit protective circuit breaker). This step is required to provide overcurrent protection and mains disconnection. The circuit breaker must be easily accessible and marked as the controller disconnect device.
- **Main supply voltage:** Permanently connect the controller to the mains in accordance with the relevant national code. Relays must be suitably protected against overcurrent, using a circuit breaker rated at 10A.
- **Keep the units closed and locked.** Only authorized personnel should open and close the units.

4.4 Devices Specifications

Table 9: Summary

I/O type	Qty
Analogue Output	16
Analogue Input	16
Digital Input	8
Temperature Sensors	16
Relays	70

Table 10: Output Devices

Device type	Maximum Number of Devices	Number of Relay Devices	Number of Analog Devices
Cooling Pads	4	4	N/A
Foggers	16	16	N/A
Heaters	16	16	16
High Heaters	16	16	16
Inlets	4	4	4
Outlet	1	N/A	1
Tunnel Doors/Curtains	4	4	4
Fans Exhaust/Tunnels	30	30	30

Device type	Maximum Number of Devices	Number of Relay Devices	Number of Analog Devices
Stir Fan	10	10	10
Blowback Fan	1	1	N/A
Timers	5	5	N/A
Auger	2	2	N/A
Feeder	4	4	N/A
Lighting	4	4	4
Water on Demand	3	3	N/A
As Relay	70	70	N/A
As Analog Output	16	N/A	16
Alarm	1	1	N/A





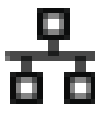



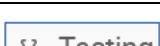



Table 11: Sensors

Device type	Analog Sensors	Digital Sensors
Temperature Sensors	16	N/A
Outside Temperature Sensor	1	N/A
Humidity Sensors Inside	2	N/A
Humidity Sensor Outside	1	N/A
CO2 Sensors	1	N/A
Ammonia Sensors	1	N/A
Pressure Sensors	1	N/A
Lux Meter (Non-USA)	1	N/A
Bird Scale	4	N/A
Silo Scale	4	N/A
Potentiometers	4	N/A
Water Meters	N/A	4
Gas Meters	N/A	3
Power Meters	N/A	2
Air Pressure	1	1
Water Pressure	1	N/A
Augur Sensor	N/A	2
Batch Counter		1

Device type	Analog Sensors	Digital Sensors
Batch Hopper Limit	N/A	1
Batch Weigher	1	N/A
Feeder Line Sensor	N/A	4
Feed Weighing by Pulse	N/A	2
RSU	N/A	2
RLED-2	2	N/A

5 Using the Trio Touch Screen

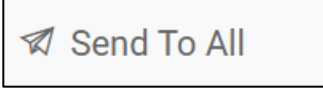

		Go back to the previous screen
		View the Main menus
		Choose language
		Network settings
		View alarms
		Go back to the main screen
		Function settings
		Function test
		Edit parameters
		Replace the dashboard battery with a RENATA-CR2450N battery.
		Click this icon to delete data stored on that page.

Phone App	
	Click the circle containing the user name to edit personal preferences such as the language, units, name, and more.
	When a Trio controls two or more rooms or there are two or more houses on a farm, Send to All enables editing certain select functions in more than one room or house. Edit the setting, click Send to All, and select the required Trios. The select rooms' or houses' settings are updated. Note: Send to All does not appear on every screen.

6 Mapping and Defining the Input Output Devices

NOTE Munters recommends that a trained technician perform the following operations.

Ü Perform a cold start (System > General Settings > About > Reset Factory Settings) after:

- connecting all devices to the Rotem Trio Expansion 70 and Rotem Trio Controller
- connecting the Rotem Trio Expansion 70 to the Rotem Trio Controller
- Understanding the Devices and Sensors Screen
- Using the Mapping Screen
- Editing Relays and Sensors
- Defining Sensors
- Defining Devices
- Mapping the Weighing Devices
- Defining the Trio RPS
- Testing Devices

6.1 Understanding the Devices and Sensors Screen

The Device and Sensors screens show:

- Trio screen: This screen displays the digital/analog input/analog output ports. What appears on this screen depends on each unit's particular setup.
- Relay screen: This screen displays the Rotem Trio Expansion 70's relays.
- Figure 72 and Figure 73 display a setup but each particular setup can be different.

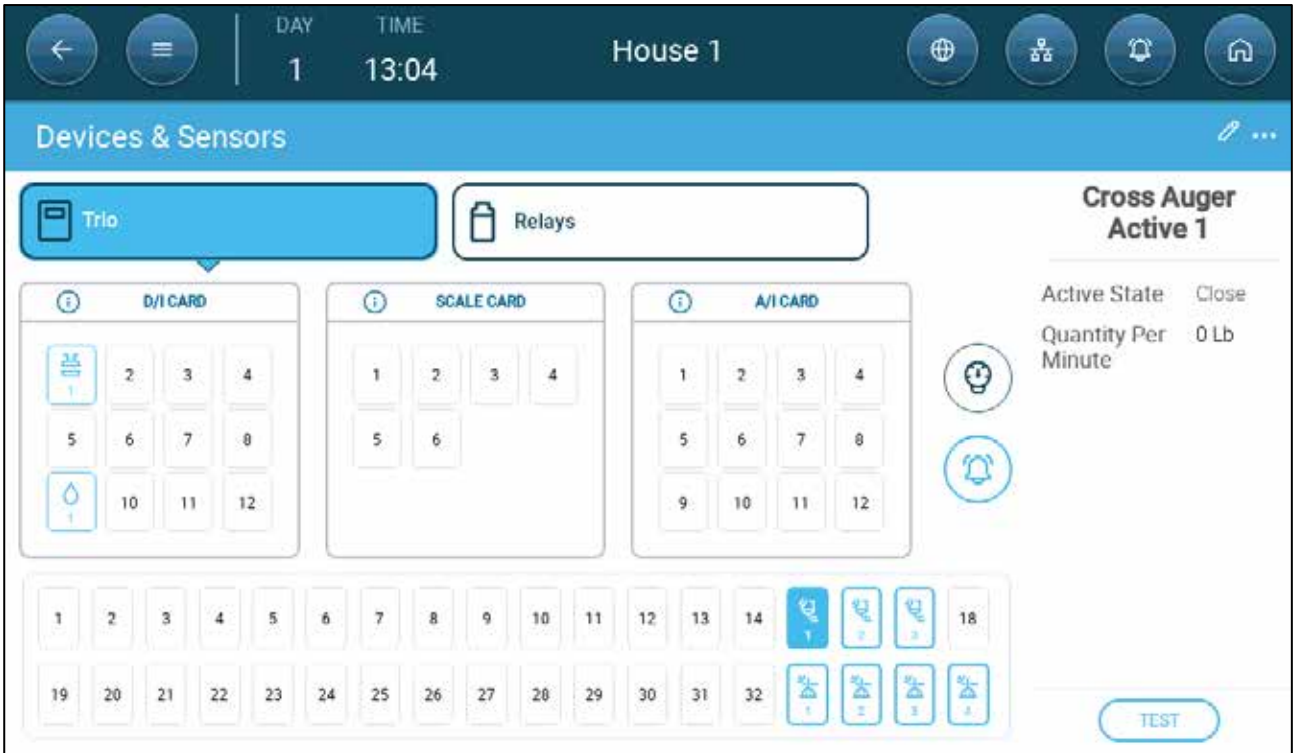

Figure 76: Low voltage input/output ports (example)

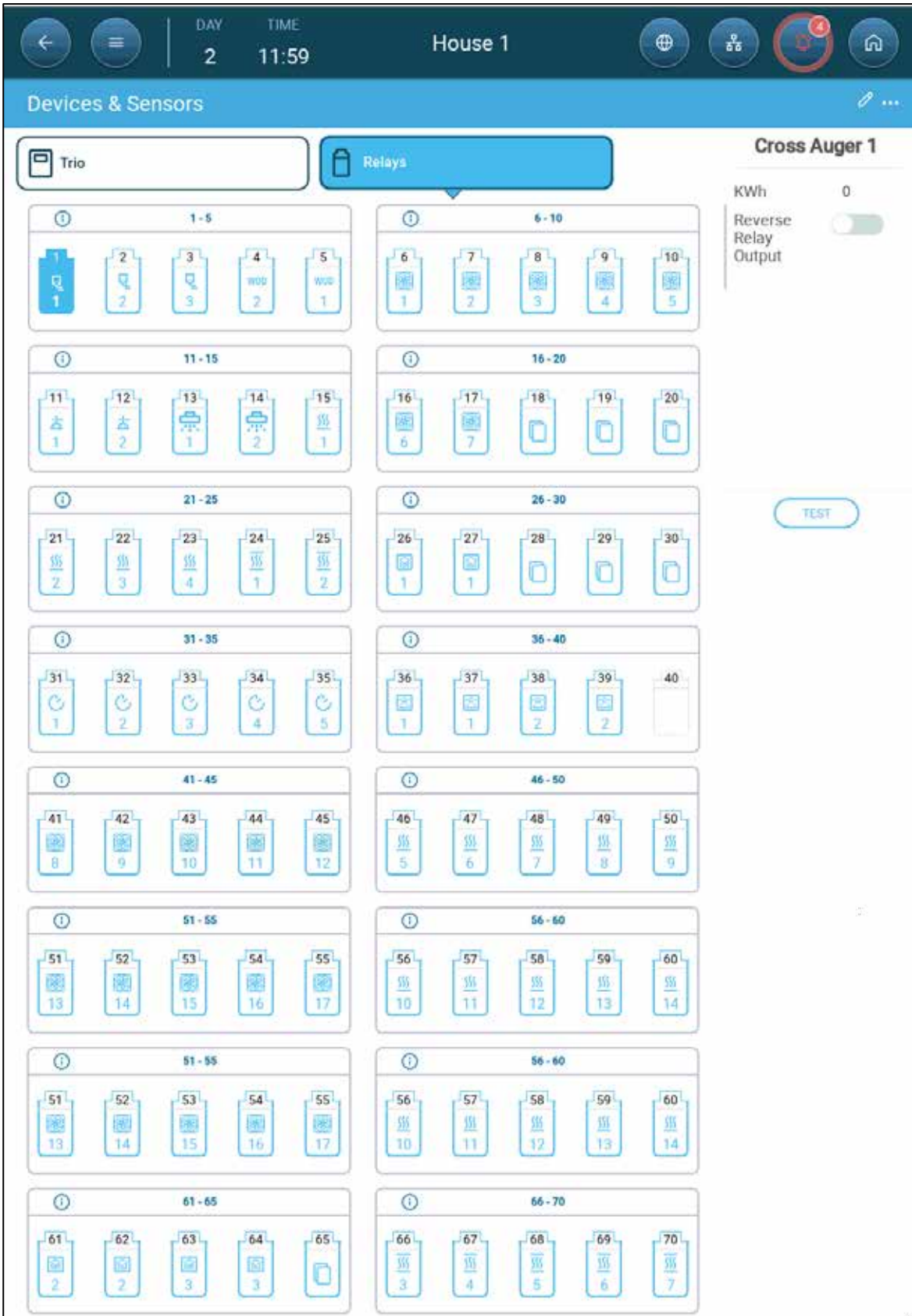

Figure 77: High voltage ports (example)

6.2 Using the Mapping Screen

After wiring devices to the Trio, each device and sensor must be mapped and then defined. Mapping and defining devices enable the system software to control each device's functionality.

CAUTION Mapping MUST match the physical wiring! An error message appears if the physical device is not wired to the relay or port as defined on the mapping screen.

1. Go to System > Device & Sensors.

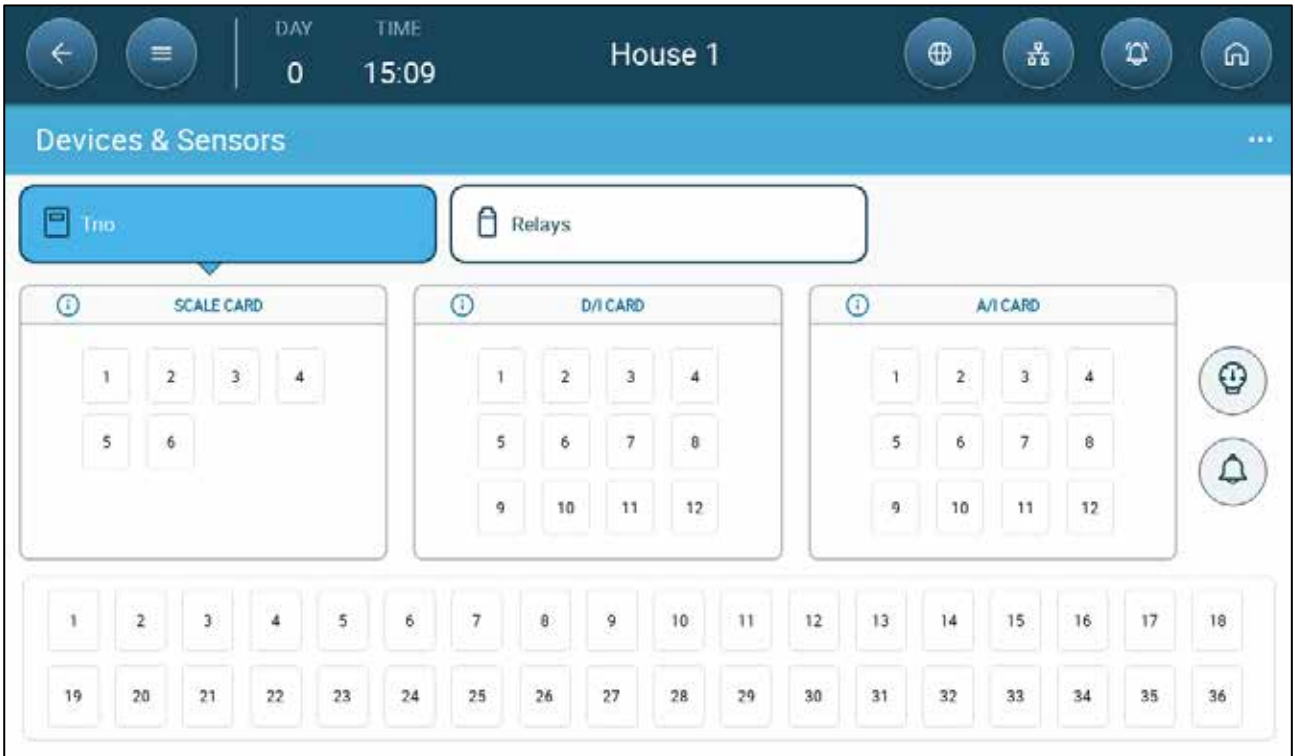

This screen displays the relays and analog/digital ports. At this point all, icons are undefined.

2. Click the Installation icon .



- Click **Sensors** to map auxiliary inputs, sensors, meters, and potentiometers.
- Click **Devices** to map cooling devices, heaters, inlets, fans, stir fans, timers, tunnel doors, outlets, or the alarm relay.

NOTE Map the sensors first and then map the devices.

3. Under Trio/Sensors, click the type of sensor that you want to map. In the following example, Temperature Sensor is selected. The screen displays the ports (and the number of ports selected) that can be defined as temperature sensors.



4. Repeat steps 3 for all the connected sensors.

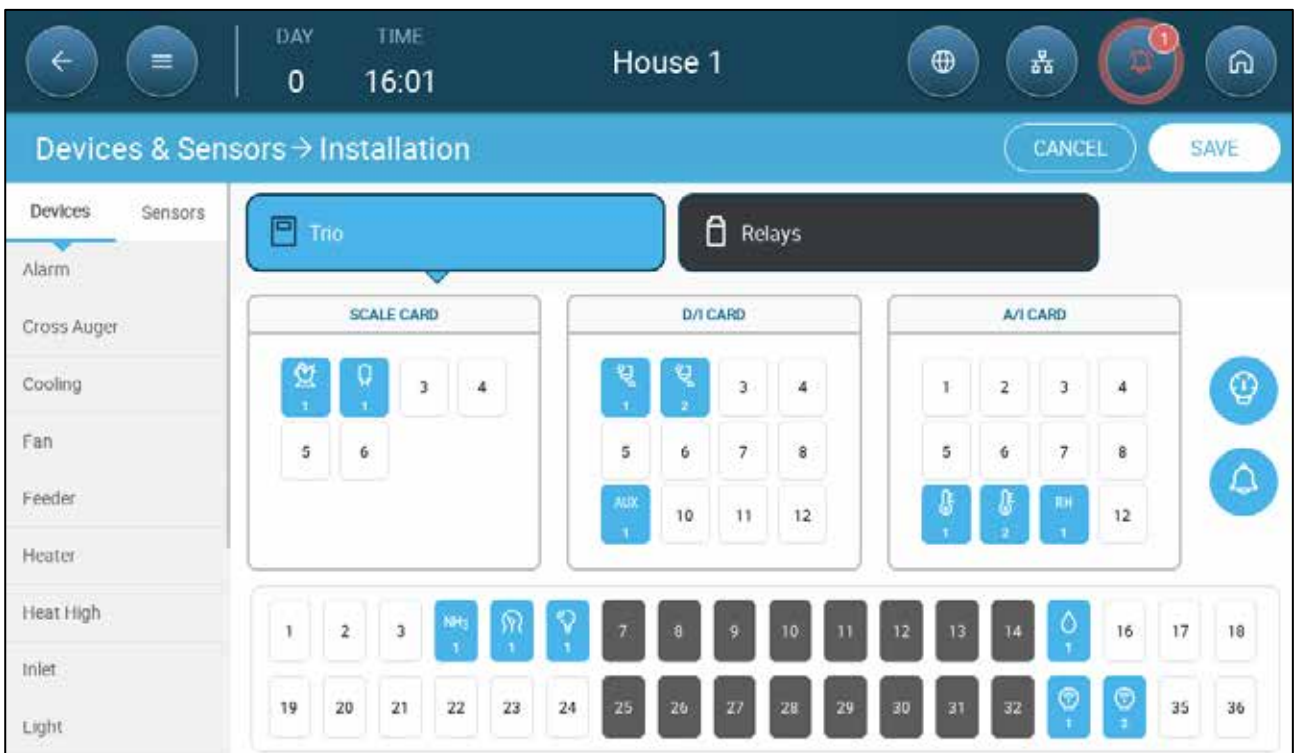

5. Under Relays, repeat the process for the high voltage devices.

NOTE : Relays control on/off devices. Any device controlled by 0 – 10 voltage is mapped to an analog input/output port.



- Trio automatically numbers the devices and sensors.
- Trio enables selecting up to the maximum number of each device.
- Devices having opening and closing relays require mapping of both relays.

6. After mapping all installed devices, **SAVE**.

NOTE If you map an analog sensor that is not physically connected to the Trio, an error symbol appears on the designated analog port.

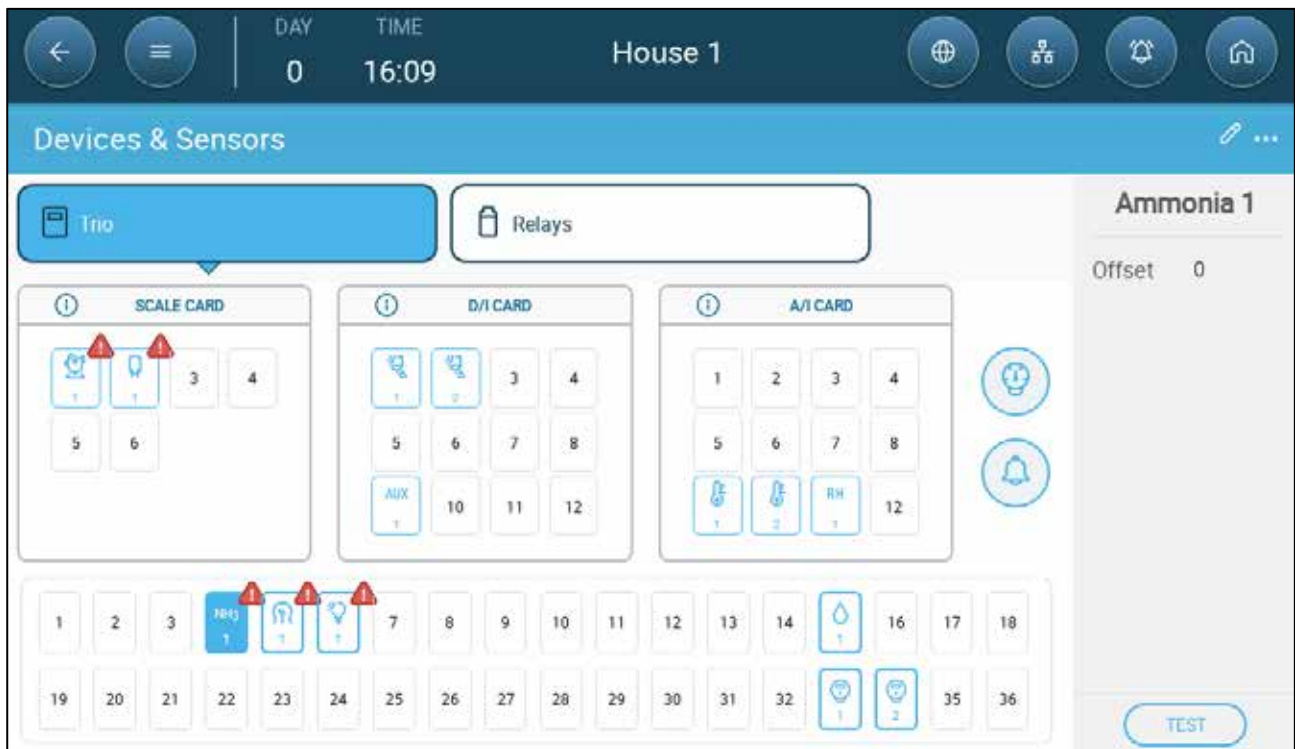

6.3 Editing Relays and Sensors

1. On the Device and Sensors screen, click a relay or sensor.



2. Click .
3. Edit the parameter(s).
4. Click Save.

6.4 Defining Sensors

- Defining Analog Sensors
- Defining Digital Sensors

6.4.1 DEFINING ANALOG SENSORS

- Enabling/Disabling Analog Input Sensors
- Temperature Sensors
- Defining the Ammonia Sensor
- Defining the CO2 Sensor
- Defining the Humidity Sensors
- Defining the Light Sensor

6.4.1.1 Enabling/Disabling Analog Input Sensors

By default, when the user maps an analog input sensor, the sensor is enabled. To disable a sensor:

1. Go to the device and click edit .
2. Move the enable mode icon to off and click Save.

Outside Temperature 1

Enable Mode

Offset °F

3. On the dashboard, the disabled sensor is marked.

6.4.1.2 Temperature Sensors

- Defining the Temperature Sensors
- Mapping the Temperature Sensors
- Enabling a Weather Station

6.4.1.2.1 Defining the Temperature Sensors

Ü Define up to 16 analog input ports as temperature sensors (and one port as an outside temperature sensor).

The image shows two side-by-side screenshots of a configuration interface. The left screenshot is titled "Temperature 1" and displays a table with two rows: "Offset" with a value of "0 °F" and "Location" with a value of "Front". Below the table is a "TEST" button. The right screenshot is titled "Outside Temperature 1" and displays a table with one row: "Offset" with a value of "0 °F". Below the table is a "TEST" button.

- Define:
 - Offset: This is an optional correction for the temperature sensor. Range: -10°C to $+10^{\circ}\text{C}$
 - Location: Designate the area in the room where the sensor is located (front/back/center).
- The temperature reading shows the measured temperature, including the offset.

6.4.1.2.2 Mapping the Temperature Sensors to Devices

Calculating the temperature data, Trio takes the following into consideration:

- Tunnel temperature: Select a sensor or a group of sensors to determine the tunnel temperature readings or select if the tunnel runs according to the average temperature reading.
- Average temperature: Data from multiple sensors can be averaged. If a sensor fails, the sensor's data is removed from any calculations.
- Device temperature: A sensor (or sensors) can be mapped to a specific device.

- Outside temperature: The temperature sensor defined as an outside temperature is not included in any average calculation.

Map specific temperature sensors to specific devices.

1. Go to System > Temperature Definition.

Device	Avg.	Temperature Sensors	Outside
Full House	<input checked="" type="checkbox"/>	1 2 3	
Cooling 1		1	
Timer 1			
Timer 2			<input checked="" type="checkbox"/>
Timer 3		2	

2. Map the sensors to devices.

- Define which sensors are used to calculate the average temperature.
- If an outside temperature sensor is enabled, map timers to it (if required).

NOTE Uninstalling a device in the Relay Layout, Analog Output or TRIAC tables removes the device from this screen.

6.4.1.2.3 Enabling a Weather Station

To save costs on temperature sensors, one outdoor temperature sensor can provide data to the entire Trio network.

NOTE Install and map one outdoor sensor only.

1. In System > Device and Sensors, define one sensor as Outside Temperature.

2. Go to System > Control Strategy > Weather Station .

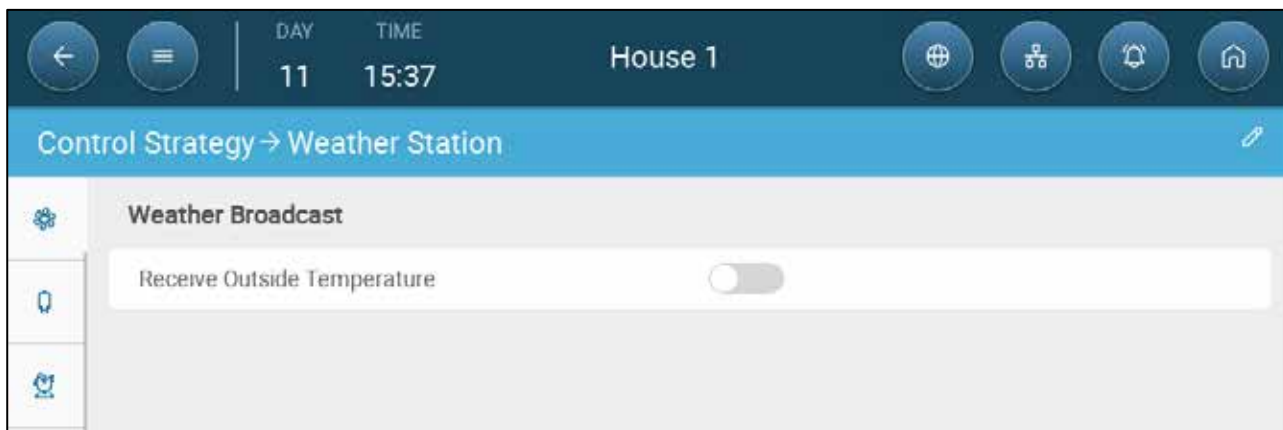

3. Enable Receive Outside Temperature.

6.4.1.3 Defining the Ammonia Sensor

Ü Define one analog input port as an ammonia sensor.

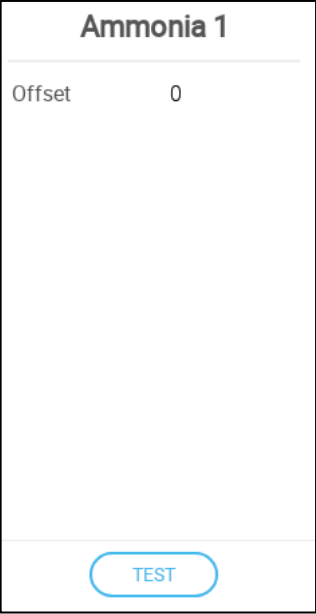

- Define:
 - Offset: This is an optional correction for the ammonia sensor. Range: -10 to +10 ppm

6.4.1.4 Defining the CO2 Sensor

Ü Define one analog input port as a CO2 port.

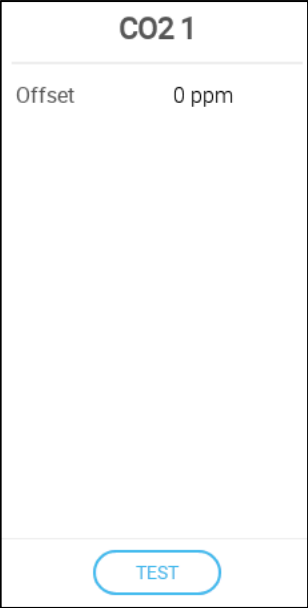

- Define:
 - Offset: This is an optional correction for the CO2 sensor. Range: -500 to +500 ppm

6.4.1.5 Defining the Humidity Sensors

Ü Define:

- One or two analog input ports as a humidity sensor
- One analog input port as an outside humidity sensor (option)
- The outside humidity is used to collect data, not to adjust climate control.

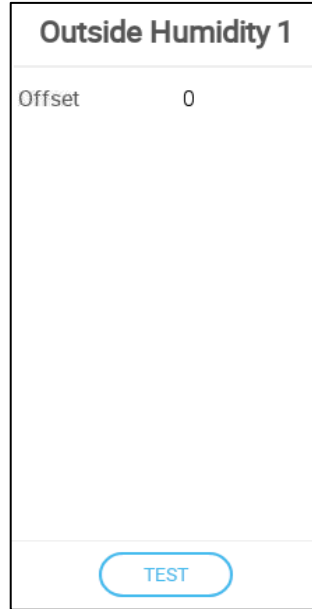
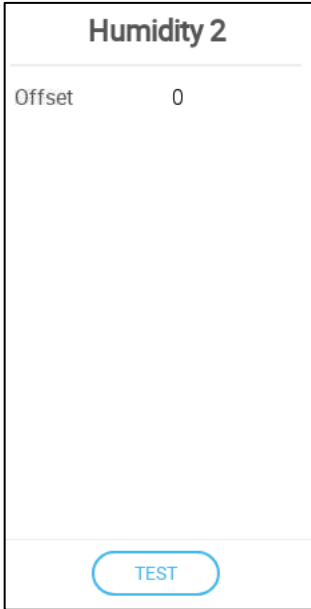

- Define:
 - Offset: This is an optional correction for the humidity sensor. Range: -10 to +10%
- The humidity reading shows the measured level, including the offset.

6.4.1.6 Defining the Light Sensor



- Define:
 - Enable Mode: Enable/disable the sensor.

6.4.2 DEFINING DIGITAL SENSORS

- Defining the Water Meter Sensors
- Defining the Gas Meter Sensors
- Defining the Power Meter Sensors
- Defining the Auger Active Sensors
- Defining the Feeder Active Sensors
- Defining the Auxiliary Input

6.4.2.1 Defining the Water Meter Sensors

Ü Define up to four (4) digital input ports as a water meter.

Water Meter 1	
QTY/Pulse	0.3 G
Meter Input	Drinking Water
<input type="button" value="TEST"/>	

- Define:
 - Quan/Pulse: Set the water meter’s water flow per pulse. Range: 0.0 to 99.9 (unit depends on the General Settings > User.)
 - Meter input: Chose drinking water or cooling.

NOTE *Cooling refers to water used in the cooling pad or the foggers. However, the data history shows the quantity of each function separately.*

6.4.2.2 Defining the Gas Meter Sensors

Ü Define up to three digital input ports as a gas meter.

Gas Meter 1	
QTY/Pulse	0.3 G
TEST	

- Define:
 - Quan/Pulse: Set the gas meter's flow per pulse. Range: 0.0 to 999 (unit depends on the General Settings > User).

6.4.2.3 Defining the Power Meter Sensors

Ü Define up to two digital input ports as a power meter.

Power Meter 1	
Power Source	Main
Pulses per kW	1
TEST	

- Define:
 - Power Source:
 - § Main: Power meter measures the amount of electricity used by the system.
 - § Heat: Power meter measure the amount of electricity used by the heaters.
 - Pulses per KW: Define the number of pulses to be counted when a kilowatt of electricity is used.

6.4.2.4 Defining the Auger Active Sensors

Ü Define up to two digital ports as auger active.

Cross Auger Active 1

Active State	Close
Quantity Per Minute	0 Lb

TEST

- Define:
 - Active state:
 - § Open: The circuit is open when the sensor is activated.
 - § Closed: The circuit is closed when the sensor is activated.
 - Quantity Per Minute: Define the amount (weight per minute) of feed to be distributed.

6.4.2.5 Defining the Feeder Active Sensors

Ü Define up to four digital input ports as feeder active.

Feeder Active 1

Active State	Close
--------------	-------

TEST

- Define the active state.
 - Open: The circuit is open when the sensor is activated.
 - Closed: The circuit is closed when the sensor is activated.

6.5.1 INTRODUCTION TO DEVICE DEFINITION

Devices can be controlled by high voltage relays, 0 – 10V analog output ports, or both.

- Current Sense Relays
- Defining 0 – 10V Analog Output Ports

6.5.1.1 Current Sense Relays

Version 9.0 supports current sensor relays. These sensors monitor the electrical current of connected equipment to ensure the devices' optimal operation. In the event that the current is too high or too low, an alarm is generated. Inlets, tunnel doors, and alarms do not support current sensors.

6.5.1.1.1 Set Up

To enable monitoring the current sense:



1. In System > Devices & Sensors, define a relay as a required device.
2. On the relay screen, enable the current sense function.
3. Define the low and high currents. Default: 0. Range 0: - 15.0 amp.
Recommended: 20 to 30% above and below the device nominal current.
 - For example, the nominal current of 2HP 54" tunnel fans is 6 amp.
 - § High current: 7.2 to 7.8 amps.
 - § Low current: 4.2 to 4.8 amps.

NOTE The high current must be above the low current.

Once the current sense is enabled, the current is displayed on the relay screen.

6.5.1.1.2 Monitoring and Alarms

- After a device is activated, the current sensor waits 15 seconds before beginning to monitor the current.
- If the measured current exceeds the high threshold or falls below the low threshold for 30 seconds, an alarm is generated.

WARNING! *After an alarm is generated, the device shuts down to prevent damage to the equipment. The device must be reset to resume operations.*

- For example, if the current monitoring system detects a high current in an auger, Rotem Trio treats the auger as if it had been manually turned off through the toggle switch.

6.5.1.2 Defining 0 – 10V Analog Output Ports

When defining the analog output ports, the user has to define the minimum and maximum voltage. These minimum and maximum levels determine the minimum and maximum outputs. For example, if in a variable speed fan the minimum voltage is set to 2V and the maximum to 8V, the controller applies the calculated 0-100% output over a 2V-8V signal.

6.5.2 DEFINING THE FANS

The following sections detail how to configure fans.

NOTE *These settings should be configured by a technician familiar with the fan and inlet/curtain specifications.*

Fan air capacity defines how much air is provided when the fans run at full speed. These numbers are used to calculate minimum air requirements.

Ü In General Settings > User define the measurement unit.

Ü Define up to 30 relays or analog output ports as On/Off or 0 – 10 V fans, respectively.

- On-Off Fans
- 0 – 10 Volt Fans

6.5.2.1 On-Off Fans

Fan 1	
Capacity	0 CFM
KWh	0
Reverse Relay Output	<input type="checkbox"/>
TEST	

- Define:
 - Capacity: Enter the fan capacity.
 - KWh: This field displays the amount of kilowatts used. Read-only.
 - Reverse Relay Output: Enable this function for Normally Closed Relays.

6.5.2.2 0 – 10 Volt Fans

Fan 3	
Min. Voltage (V)	0
Max. Voltage (V)	10
Min. Capacity	0 CFM
Max. Capacity	0 CFM
KWh	0
Boost Time (sec.)	5
TEST	

- Define:
 - Minimum/Maximum Voltage: Enter the minimal and maximal voltage used to calibrate the fan speed.
 - Minimum/Maximum Capacity: Enter the fan's minimum and maximum capacity.
- NOTE** *The fan delivers the minimum capacity when running at minimum speed.*
- KWh: This field displays the amount of kilowatts used. Read-only.
 - Boost Time: During this amount of time, the controller applies full power to the fan motor (100%) and then drops to minimum speed.

6.5.3 DEFINING THE STIR FAN

Ü Define up to ten relays or ports as a stir fan.

- On Off Stir Fan
- 0 – 10 Volt Stir Fan

6.5.3.1 On Off Stir Fan

Stir Fan 1	
KWh	0
Operation	Normally Open

TEST

- Define:
 - KWh: This field displays the amount of kilowatts used. Read-only.
 - Operation: Define the relay mode.

6.5.3.2 0 – 10 Volt Stir Fan

Stir Fan 1	
Min. Voltage (V)	0
Max. Voltage (V)	10
KWh	0

TEST

- Define:
 - Minimum/Maximum Voltage: Enter the minimal and maximal voltage used to calibrate the fan speed.
 - KWh: This field displays the amount of kilowatts used. Read-only.

6.5.4 DEFINING THE BLOWBACK FAN

Ü Define one relay as a blowback fan.

Blowback Fan 1

KWh 0

Reverse Relay Output

TEST

- Define:
 - KWh: This field displays the amount of kilowatts used. Read-only
 - Reverse Relay Output: Select if the relay is normally open or normally close.

6.5.5 DEFINING HEATING DEVICES

Ü Define up to sixteen relays and/or analogue output ports as heaters.

- Defining the On/Off
- Defining the Variable Heaters
- Defining the High Heaters

6.5.5.1 Defining the On/Off Heaters

Heater 2

KWh 0

Reverse Relay Output

Ignition Time (sec.) 0

TEST

- Define:
 - KWh: This field displays the amount of kilowatts used. Read-only
 - Reverse Relay Output: Enable this function for Normally Closed Relays.
 - Ignition Time (sec.): Define the delay time between when the heater is turned on and when the gas is ignited.

6.5.5.2 Defining the Variable Heaters

Heater 3

Min. Voltage (V) 0

Max. Voltage (V) 10

KWh 0

TEST

- Define:
 - Minimum/Maximum Voltage: Define the voltage in the analogue output port that corresponds to the 0% and 100% output, respectively.
 - KWh: This field displays the amount of kilowatts used. Read-only.

6.5.5.3 Defining the High Heaters

High heaters work in conjunction with relay heaters. High heater 1 works with heater 1, high heater 3 works with heater 3, and so on. If there is no corresponding heater to a high heater, the latter does not function. For example, if there are three heaters and four high heaters, high heater 4 does not function.

Ü Define up to 16 relays as high heaters.



- Define:
 - Reverse Relay Output: Enable this function for Normally Closed Relays.

6.5.6 DEFINING THE COOLING PADS

Ü Define up to four relays as cooling pads.

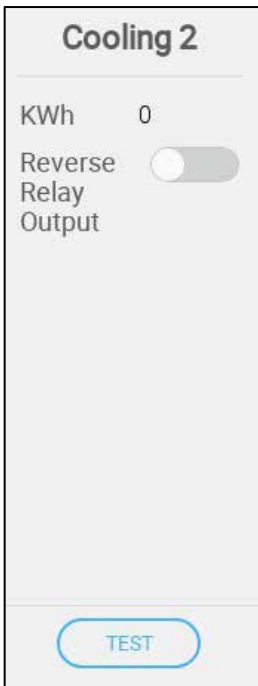

- Define:
 - KWh: This field displays the amount of kilowatts used. Read-only.
 - Reverse Relay Output: Enable this function for Normally Closed Relays.

6.5.7 DEFINING THE FOGGERS

Ü Define up to 16 relays as foggers.

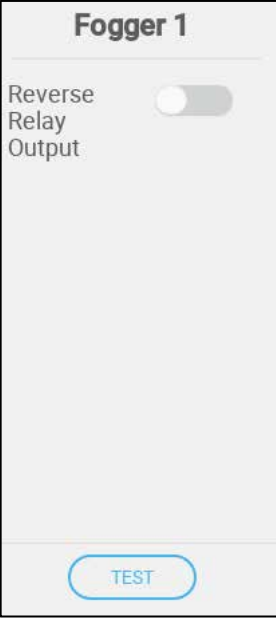

- Define:
 - Reverse Relay Output: Enable this function for Normally Closed Relays.

6.5.8 MAPPING THE POTENTIOMETERS, INLETS, TUNNEL DOORS, OUTLETS

- Mapping the Potentiometers
- Defining the Inlets/Tunnel Doors
- Defining the Outlet

6.5.8.1 Mapping the Potentiometers

Ü Define up to four analogue ports as potentiometers.

As an option, potentiometers enable exact positioning of relay-controlled inlets\tunnel doors when calibrating. If:

- potentiometers are not employed or
- there is a potentiometer failure
- opening and closing times are used to calibrate the inlets/tunnel doors.

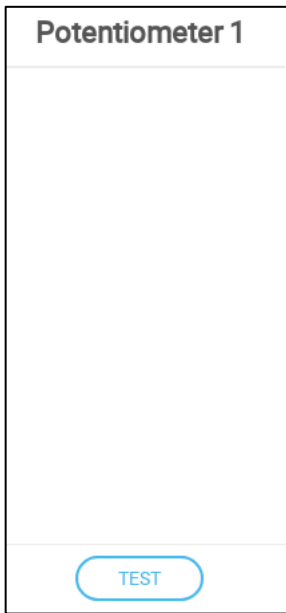

- Enable/disable the potentiometer.

6.5.8.2 Defining the Inlets/Tunnel Doors

Ü Define up to four relays or analog output ports as inlets or tunnel doors (each device requires two relays or one analogue port).

Inlet 1	
Position	By Time
Open Time (sec.)	60
Close Time (sec.)	60
Open Reverse Relay Output	<input type="checkbox"/>
Close Reverse Relay	<input type="checkbox"/>
<input type="button" value="TEST"/>	

Tunnel Door 1	
Min. Voltage (V)	0
Max. Voltage (V)	10
Open Time (sec.)	60
Close Time (sec.)	60
<input type="button" value="TEST"/>	

- Define:
 - Position: Define how the inlet opening is controlled:
 - § By time
 - § Potentiometer (relay-controlled inlets or tunnel doors only). Map each inlet/tunnel door to a potentiometer. This option appears only if potentiometers are mapped.
 - Open/Close Time: Measure and enter the amount of time required to fully open or fully close the inlet. These parameters are only enabled when Position/By Time is selected.
 - Reverse Relay Output: Enable this function for Normally Closed Relays.
 - Calibrate: Manually calibrate inlets/tunnel doors positioned by a potentiometer. Potentiometer-controlled calibration only.

6.5.8.2.1 Potentiometer Calibration

If used, a potentiometer can control the opening and closing with a high degree of precision. When there is no potentiometer, positioning accuracy tends to degrade after the inlets go through several opening and closing cycles.

In order to calibrate an inlet/vent/tunnel door using a potentiometer:

- Install and map a potentiometer.
- Define the relay-controlled inlet/vent/tunnel door that the potentiometer controls. (Analog controlled devices don't require a potentiometer.)

- Calibrate the potentiometer. Calibration must be successful.

In for any reason potentiometer calibration does not function:

- Calibration is by time (auto and/or at power up). Time calibration does not fail.
- A potentiometer alarm is generated (if alarms are enabled). The alarm must be reset to enable potentiometer calibration to function.

6.5.8.2.2 Calibrating the Inlets/Tunnel Door

During installation, the user enables auto-calibration or power up calibration in digital output (relay) inlets. Calibration automatically takes place after the number of inlet movements equals the number of movements required to start calibration or at Trio power up.

Only one inlet or tunnel curtain can be calibrated at a time.

- Relay open occurs when the target position is 100%.
- Relay close occurs when the target position is 0%.

1. Go to System > Control Strategy > Ventilation .

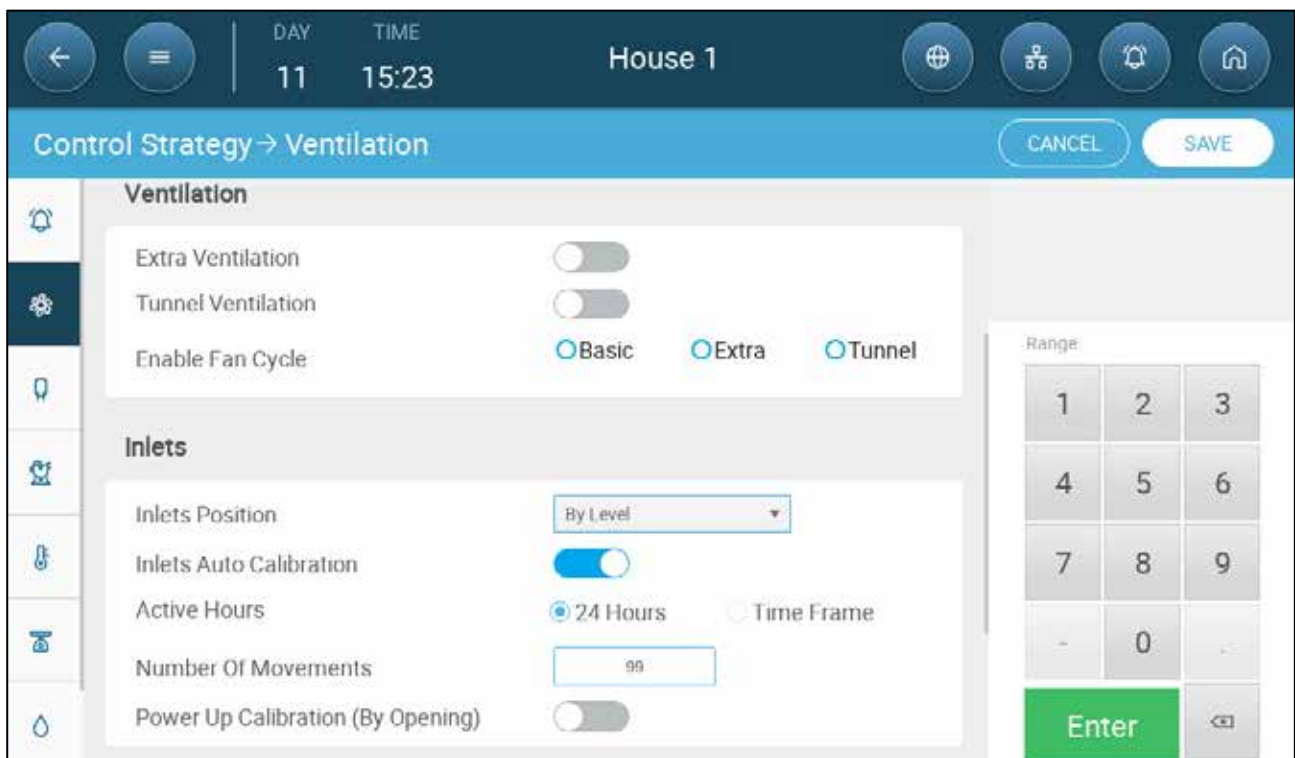

2. Click .

3. Define:

- Inlets Position Choose By Level or By Pressure. Refer to the User Manual for more details.
- Inlets Auto Calibration: Enable if required.
- Active Hours: Select 24 hours a day or define a specific time frame.

- Number of Movements: Set up the number of movements after which the inlet/tunnel door automatically calibrates. Range 5 – 99.
- Potentiometer-controlled calibration failure: If calibration fails (during auto or power up calibration) in a potentiometer-controlled calibration, an error symbol appears in the Devices and Sensor screen.



In this situation, click Calibrate to run the Calibration Wizard. If the calibration fails again, check:

- Potentiometer wiring
- Potentiometer
- Inlets' and curtains' opening and closing position. There must be a minimum distance between the two, equivalent to 300 A2D points.

6.5.8.3 Defining the Outlet

Ü Define one analog output port as an outlet.

Outlet 1	
Min. Voltage (V)	0
Max. Voltage (V)	10
Open Time (sec.)	60
Close Time (sec.)	60

- Define:
 - Min./Max Voltage: Define the voltage in the analogue output port that corresponds to the 0% and 100% output, respectively.
 - Open/Close Time: Enter the amount of time required to fully open or fully close the inlet.

6.5.9 DEFINING THE SAME AS RELAYS

Ü Define up to 20 relays as Same as Relay.

This function enables defining a relay to operate using the parameters defined for another relay. A relay can be tied to any other relay.

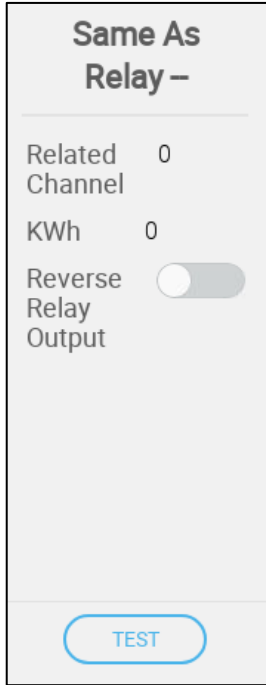

- Define:
 - Related Channel: Define which relay number to follow. Range: 1 – 20
 - KWh: This field displays the amount of kilowatts used. Read-only.
 - Reverse Relay Output: Enable this function for Normally Closed Relays.

6.5.10 DEFINING THE SAME AS ANALOG PORTS

Ü Define up to eight relays as Same as Analog Ports.

This function enables defining a relay to operate using the parameters defined for a corresponding analog port. Relays can be mapped to eight specific ports only.

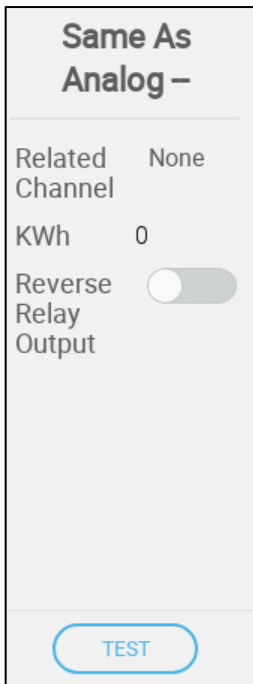

- Define:
 - Related Channel: Define which port number to follow.
 - KWh: This field displays the amount of kilowatts used. Read-only.
 - Reverse Relay Output: Enable this function for Normally Closed Relays.

Port Number	Related Channel
7	1
8	2
9	3
10	4
21	5
22	6
23	7
24	8

6.5.11 DEFINING THE TIMERS

Ü Define up to five relays as timers.

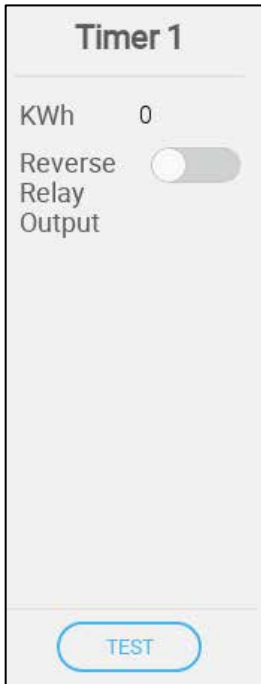

- Define:
 - KWh: This field displays the amount of kilowatts used. Read-only.
 - Reverse Relay Output: Enable this function for Normally Closed Relays.

6.5.12 LIGHTING DEVICES

Ü Define up to four relays or analog ports as light relays and one sensor as a light sensor.

- Defining the On/Off Lights
- Defining the Variable Lights

6.5.12.1 Defining the On/Off LIGHTS

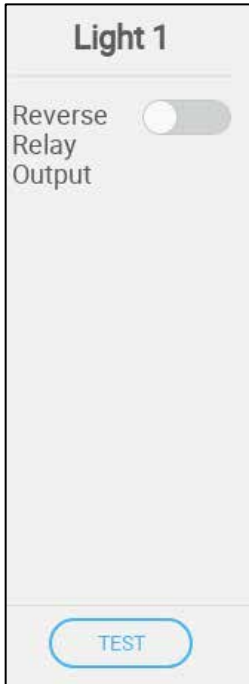

- Define:
 - Reverse Relay Output: Enable this function for Normally Closed Relays.

6.5.12.2 Defining the Variable Lights

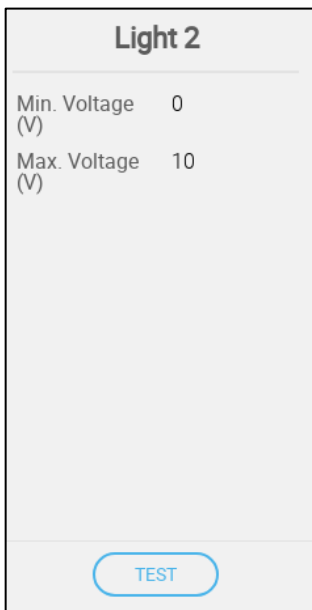

- Define:
 - Minimum/Maximum Voltage: Enter the minimal and maximal voltage used to calibrate the light strength.

6.5.13 FEEDING DEVICES

Setting up a feed system requires auger relays and sensors, and feeder relays and sensors. Define:

- Auger and feed relays to control the auger/feeder lines.
- Auger digital sensors to detect auger overtime issues: silo is empty, feed lines are stuck, or other mechanical issue.
 - Auger 1 is automatically associated with Augur Active Sensor 1. Auger 2 is automatically associated with Augur Active Sensor 2.
 - Feeder 1 active is associated to feeder 1 relay, feeder 2 active to feeder 2 relay, etc.
- Defining the Auger Relays
- Defining the Feeder Relays
- Mapping the Weighing Devices

6.5.13.1 Defining the Auger Relays

Ü Define up to three relays as augers.

- Define:
 - KWh: This field displays the amount of kilowatts used. Read-only.
 - Reverse Relay Output: Enable this function for Normally Closed Relays.

6.5.13.2 Defining the Feeder Relays

Ü Define up to four relays as feeders.

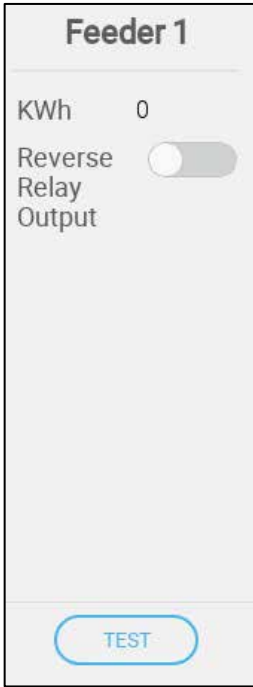

- Define:
 - KWh: This field displays the amount of kilowatts used. Read-only.
 - Reverse Relay Output: Enable this function for Normally Closed Relays.

6.5.14 FAIL SAFE DEVICES

The Fail Safe function defines extreme conditions that activate dedicated failsafe relays. These relays activate external devices used to deal with the condition.

Ü Define up to four relays as fail safe relays.

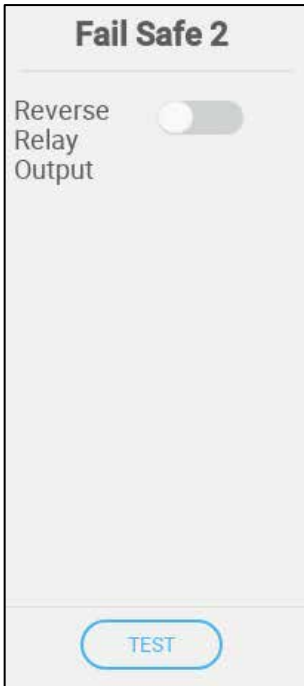

- Define:
 - Reverse Relay Output: Define the relay mode as Closed.

6.5.15 WATER PRESSURE DEVICES

- Defining the WOD
- Defining the WOD Pro
- WOD Pro Calibration

6.5.15.1 Defining the WOD

WOD relays control two pre-set pressure regulators.

Ü Define up to three relays as WOD relays.



- Define:
 - Reverse Relay Output: Enable this function for Normally Closed Relays.

6.5.15.2 Defining the WOD Pro

The WOD Pro sensor controls the water pressure and flow in all drink lines.

Ü Define one analog output port as a WOD Pro sensor.



- Define:
 - UPR Pressure: The UPR is a pressure regulator which has an adjustable range between 0 – 58 PSI.

6.5.15.3 WOD Pro Calibration

The system is factory calibrated. Calibrate the WOD Pro only if the pressure readings do not match expected values.

To calibrate the sensor:

1. Click Calibrate.

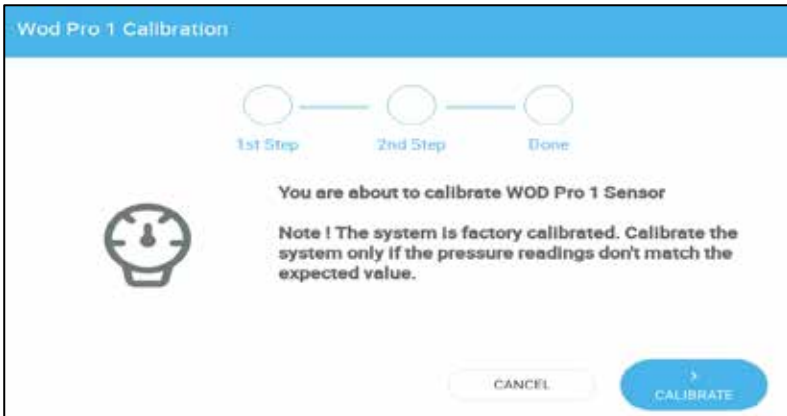

2. Click Calibrate.
3. WOD Pro supplies 2.5 volts. Enter the value of the pressure shown on the water outlet.

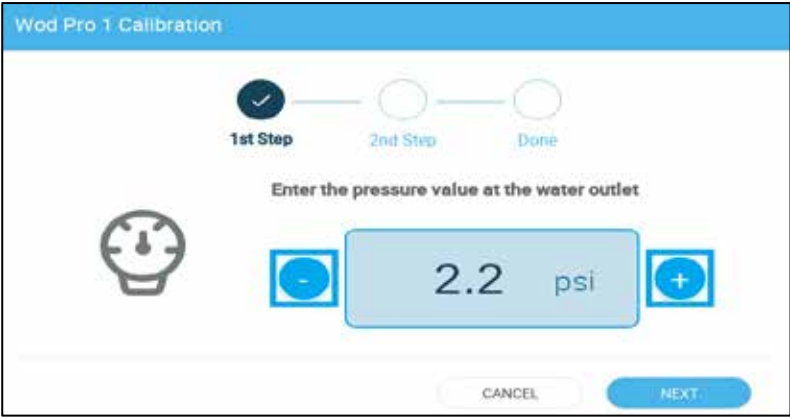

4. Click Next.

5. WOD Pro supplies 7.5 volts. Enter the value of the pressure shown on the water outlet.

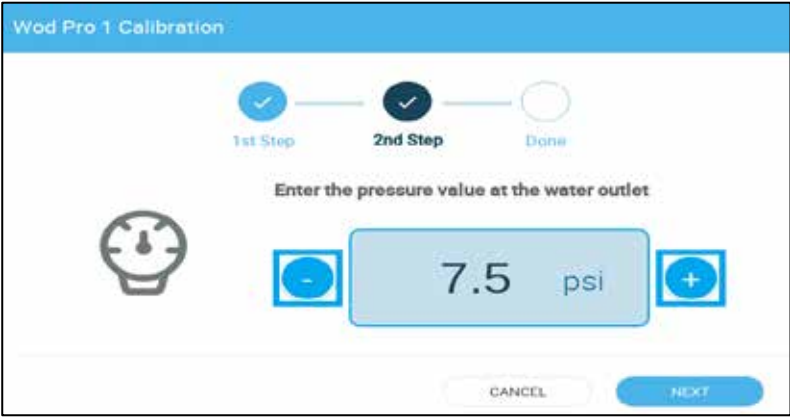

6. Click Next.

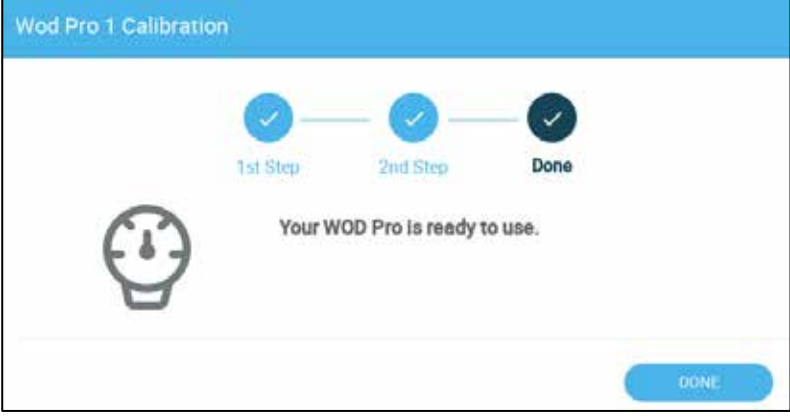

Calibration is complete.

6.6 Mapping the Weighing Devices

- Defining the Silos
- Defining BinTrac Silos
- Defining the Bird Scales
- Defining the RSU

6.6.1 DEFINING THE SILOS

- Mapping the Silo Scales
- Configuring the Silo Scale
- Testing the Silo

6.6.1.1 Mapping the Silo Scales

Trio can support up to four silo scales.

NOTE Feed mixing supports up to three silo scales. The fourth silo can only provide feed inventory data only.

Ü This function requires a scale card.



- Define:
 - Storage Capacity: Define the quantity of feed that each silo can contain.
 - Calibrate: Refer to the next section.

6.6.1.2 Configuring the Silo Scale

The following procedure details how to “zero out” the Trio silo scales. Zeroing out is way to ensure that the unit’s A2D number is accurate (shown in the Silo Icon; 430 in the picture below). To summarize the procedure:

- The user enters the correct amount of feed in the silo while calibrating the silo scale. In the Silo management screen, the user enters “0” (zero). Trio then defines the current A2D signal to be the A2D signal for an empty bin.



1. Define each silo's storage capacity.
2. Click on the silo icon and click Calibrate. The following screen appears:

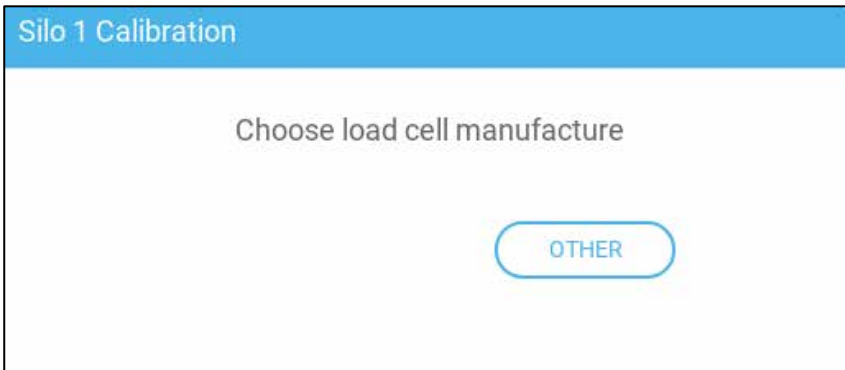

3. Click Other. The following screen appears:

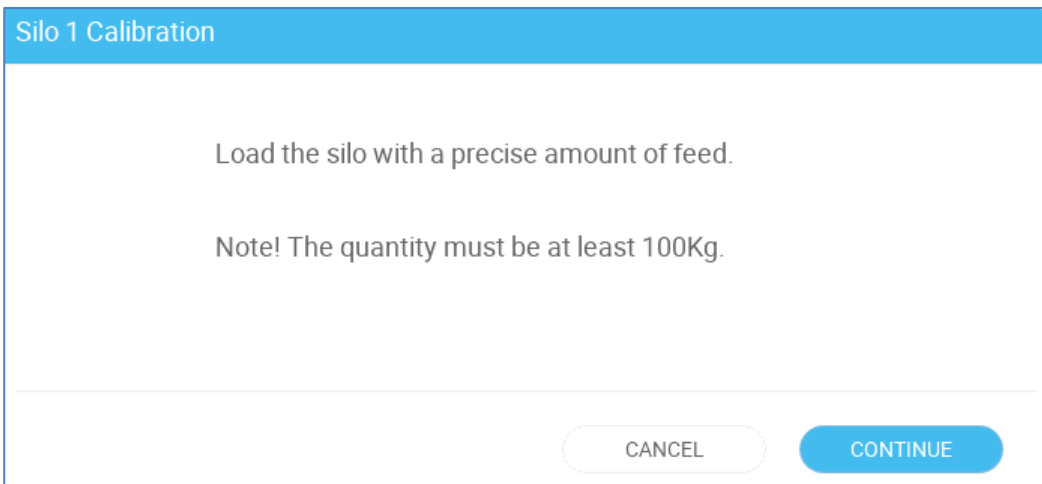

4. Fill up the silo with a known amount of feed. Munters recommends either a truck filling or a minimum of 500 kilograms.
5. Enter the amount of feed in the silo and press Continue.

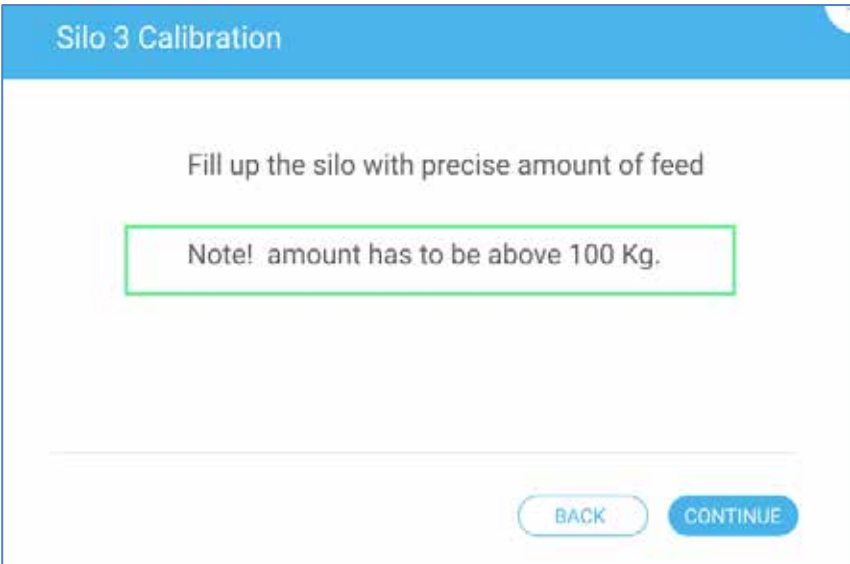

The following screen should appear.

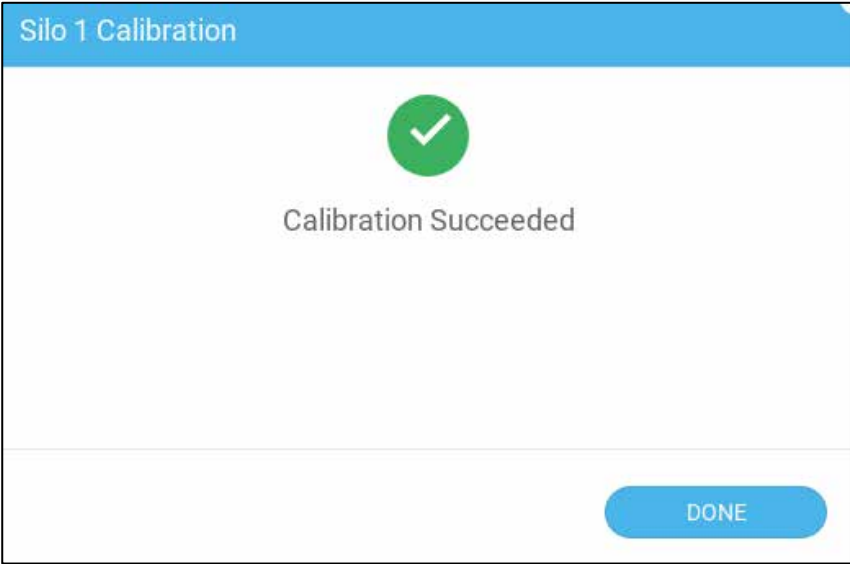

6. Go to Flock > Silo Management.

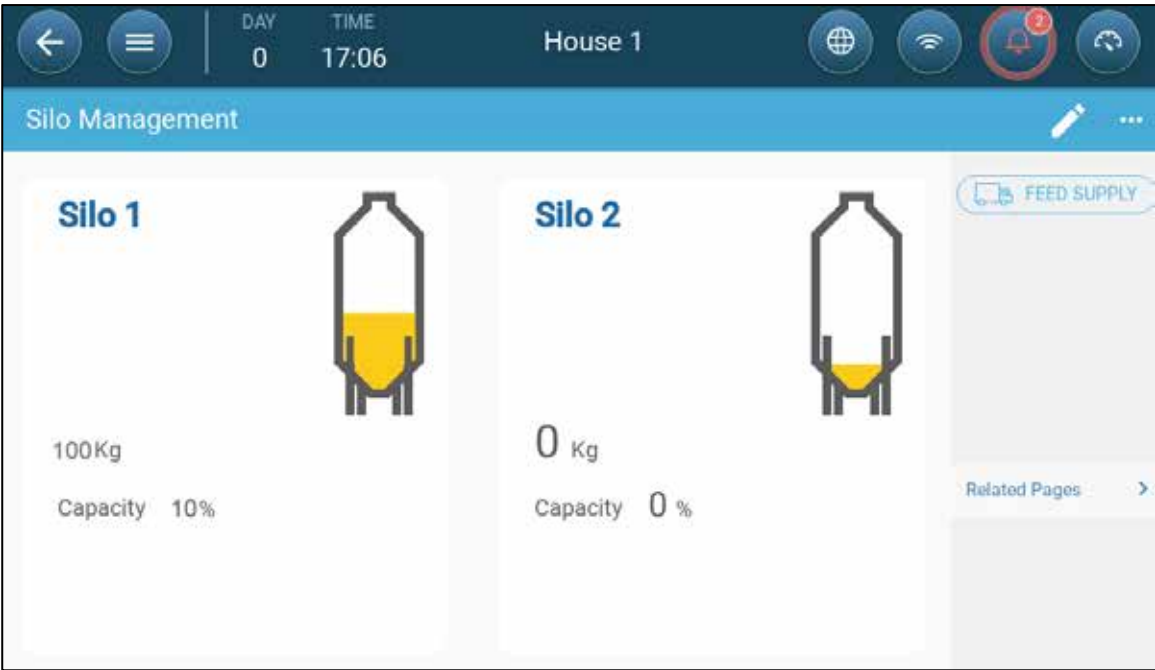

7. Click  and change the feed weight to 0.



8. Click Save.
The Trio now displays an accurate A2D number on the silo icon screen.

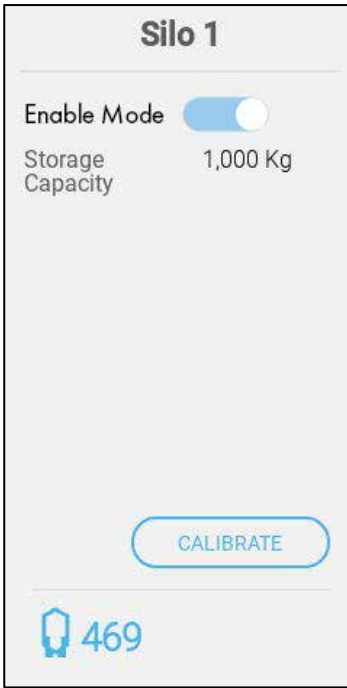

6.6.1.3 Testing the Silo

1. After calibrating the silo, go to the Silo relay.

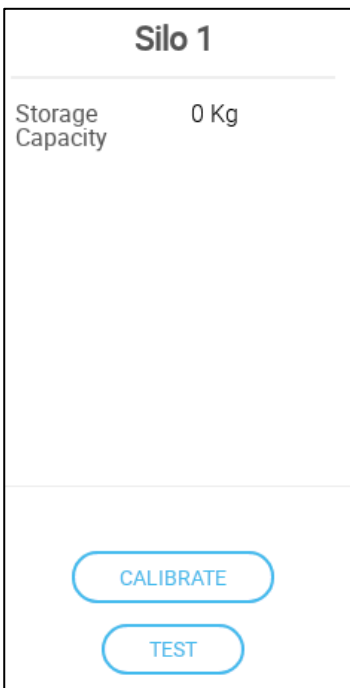

2. Click Test.

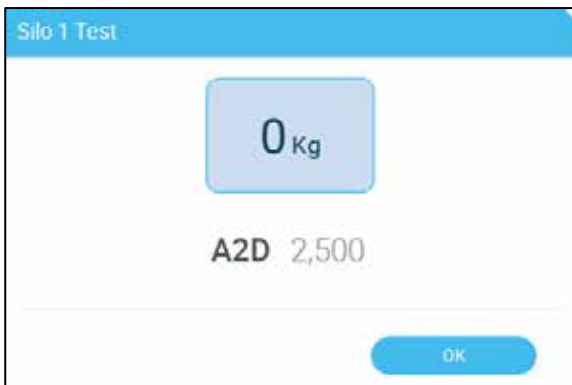

3. Place a known weight in the silo.

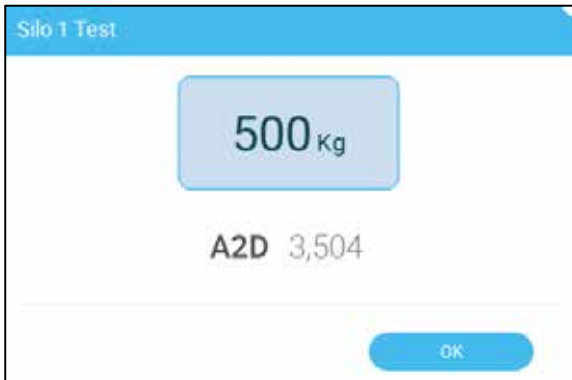

The weight should appear on the screen and the A2D level should rise.

6.6.2 DEFINING BINTRAC SILOS

TRIO can support up to three BinTrac silo scales.

Ü This function requires a scale card.

1. On the Devices & Sensors screen, click **Silo**. The Scale icon turns brown. Click the icon.

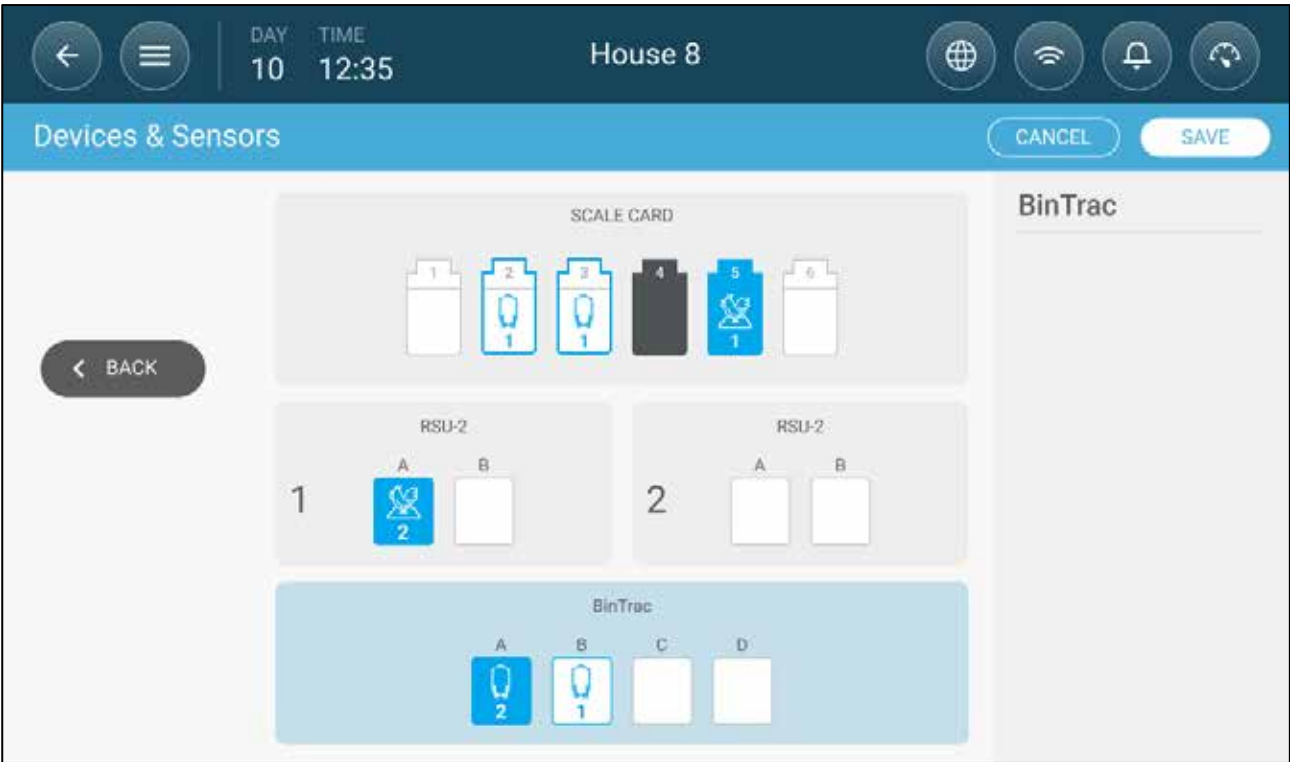

2. Define the ports as BinTrac; no parameter definitions are required.

6.6.3 DEFINING THE BIRD SCALES

- Mapping the Bird Scales
- Calibrating the Bird Scales
- Testing the Bird Scale

Rotem Trio Controller supports up to four bird scales.

6.6.3.1 Mapping the Bird Scales

Ü This function requires a scale card.

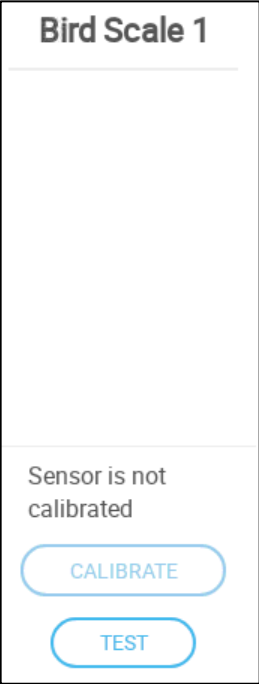

- Define up to four channels as scales.

6.6.3.2 Calibrating the Bird Scales

1. Click on a bird scale icon and click Calibrate. The following screen appears:

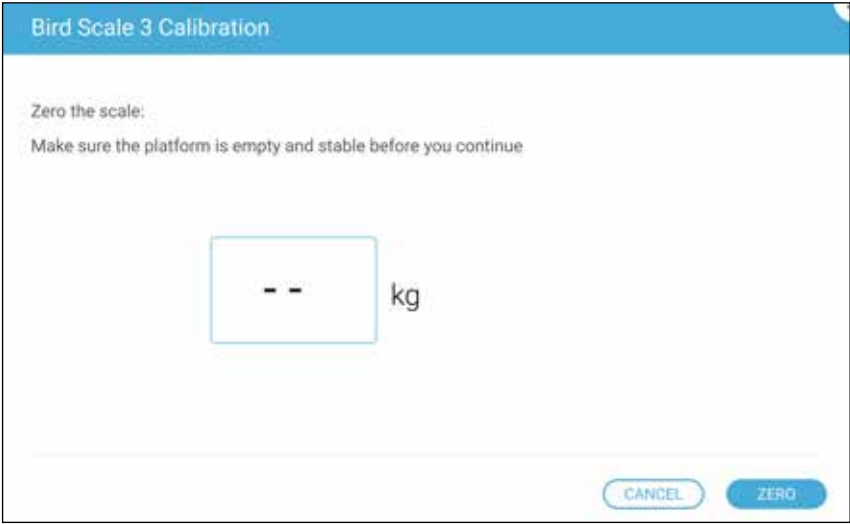

2. Remove everything from the scale and press Zero. In the following screen enter the weight being used to calibrate the scale; minimum is 1.0 kilogram. Click Next.

CAUTION *The scale must be free of any objects before pressing Next!*

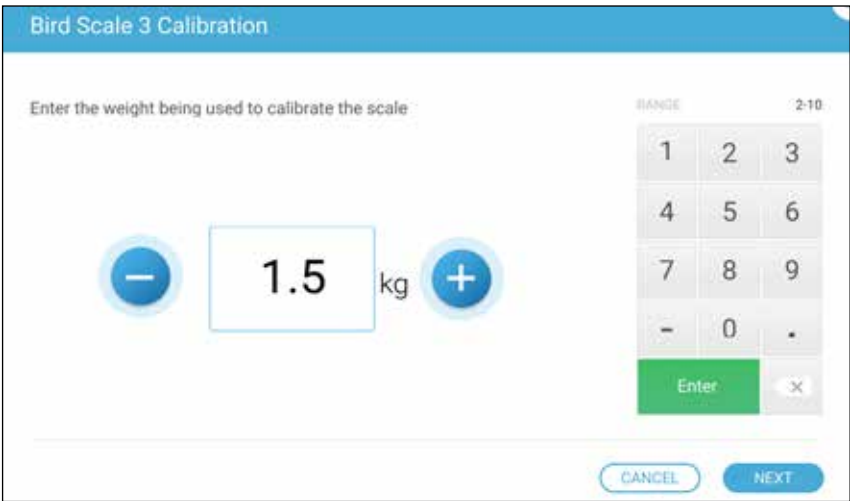

3. Place a known weight on the scale (1.5 kilograms in the below example) and press Next.

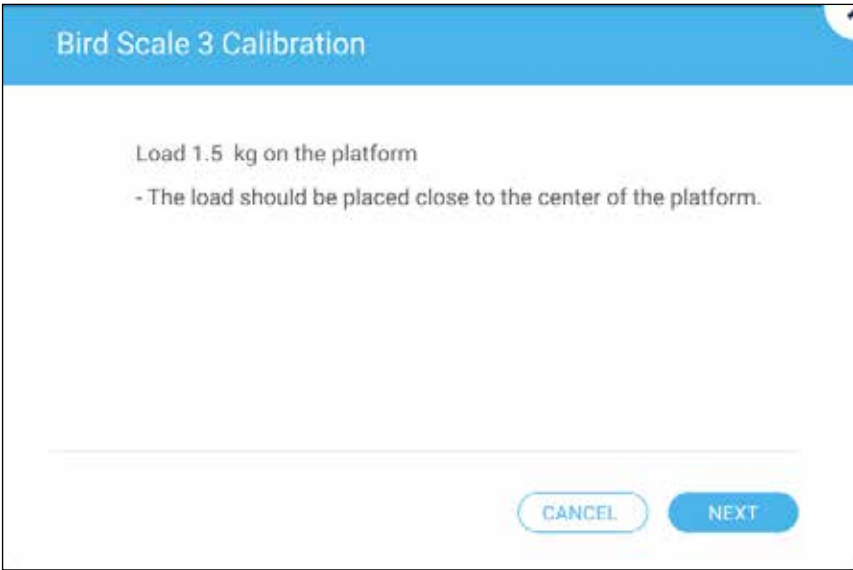

The following screen should appear:

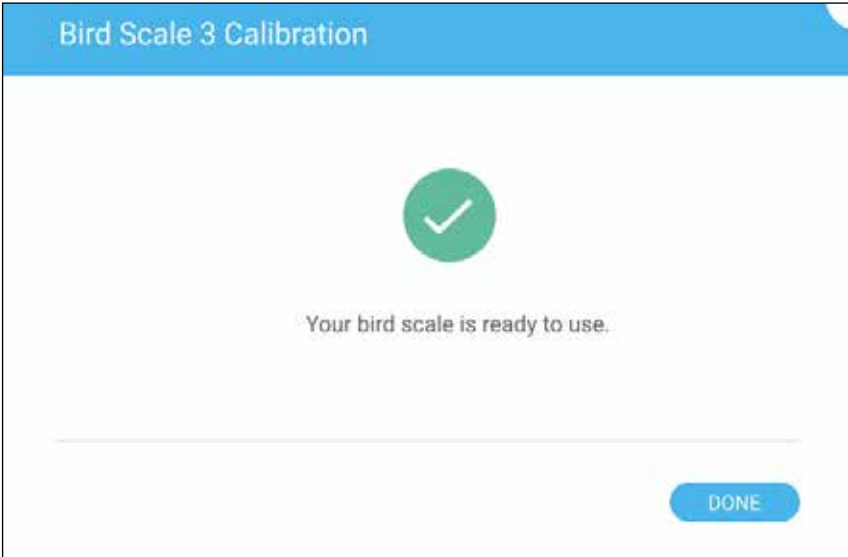

6.6.3.3 Testing the Bird Scale



1. Click Test.

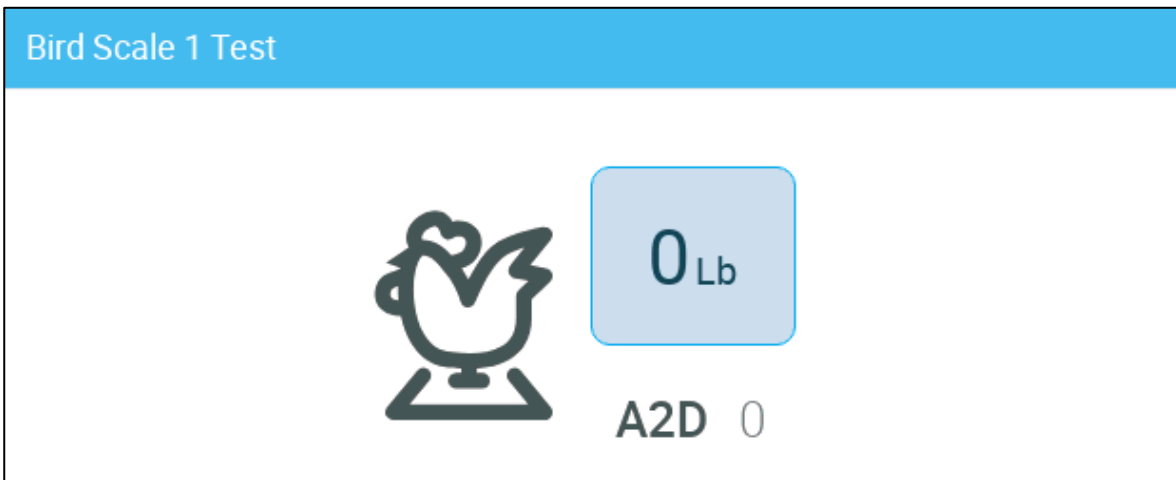

2. Place a known weight on the bird scale and click Done.

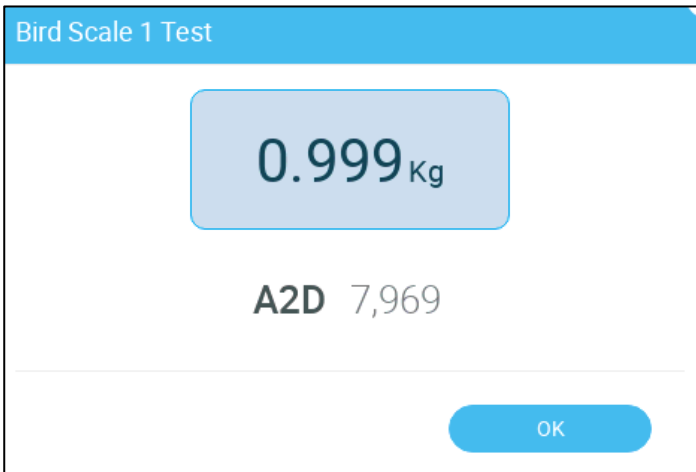

The result should be fairly close to the true weight.

6.6.4 DEFINING THE RSU

The following section details how to define up to two RSU units connected to the Trio (optional). For detailed information on using the RSU, refer to the product manual.

Ü Wire the RSU to the Trio as shown in Figure 69, page 77.

1. Reset the Trio, as shown in General Settings > About.
2. Go to Device & Sensors > Installation > Scale.



3. Click the RSU icon.
4. Click Calibrate.

Follow the instructions given in Configuring the Silo Scale, page 124.

6.7 Defining the Trio RPS

The following section details how to configure the RPS device.

- Define the Sensor
- Static Pressure Calibration

6.7.1 DEFINE THE SENSOR

1. Go to System > Devices & Sensors.

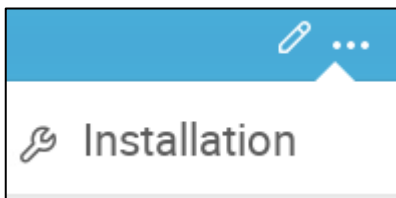

2. Click [Installation]. The Devices & Sensor screen appears.



3. Click [Sensors].
4. Click Pressure.
5. Define an analog input port as the pressure sensor. In the following screen, ports 5 is defined as the pressure sensor.



6. Go to Climate > Static Pressure and define the parameters.

6.7.2 STATIC PRESSURE CALIBRATION

CAUTION The Static Pressure sensor is factory calibrated. Only calibrate the sensor if you have reason to believe that they are producing inaccurate results.

The Static Pressure should be 0 when there is no ventilation and the house is closed. When the controller A/D counts is 100, this means that there is zero (0) static pressure.

NOTE: Run the controller for a few hours so that the temperature in the box becomes stable and only then calibrate.

CAUTION DO NOT blow the air into the hose to see if the pressure changes! The sensor is sensitive and blowing air can cause irreparable damage.

To calibrate the Static Pressure Sensor:

1. Disconnect the air hoses.
2. Go to System > Device & Sensors > Pressure.



3. Click Calibrate.

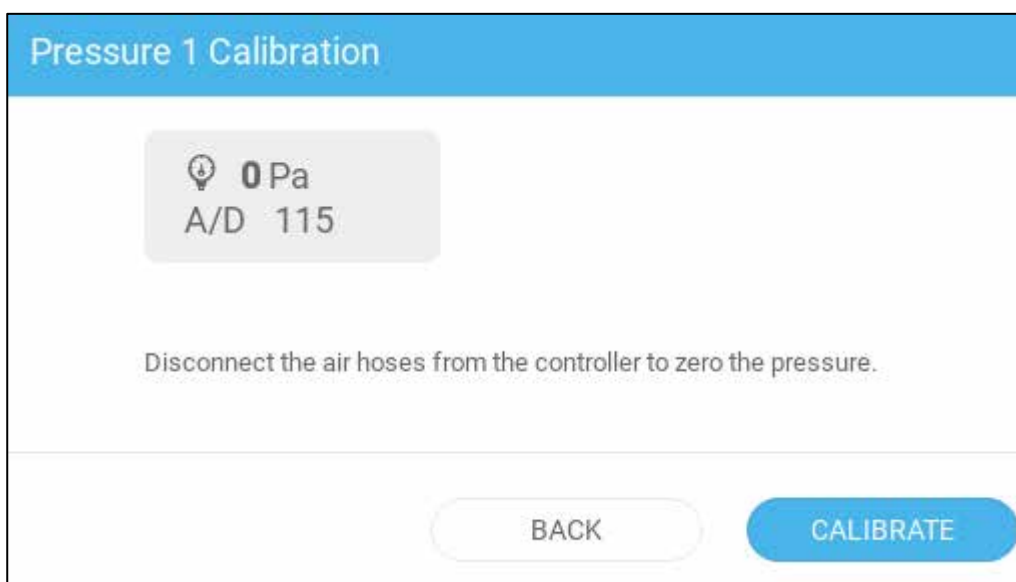

4. If the A/D count is 100 +/- 30 (70 to 130), click Calibrate.

5. If the A/D count is less than 70 or greater than 130:

- a. Check for blocked air hoses or wind interference.
- b. Open the Trio. On the Main Board, find the Static Pressure Sensor.

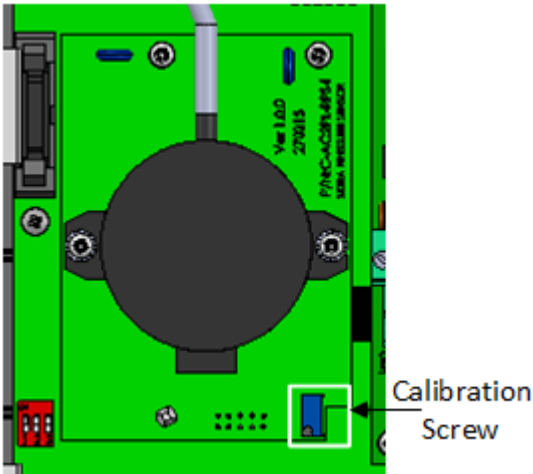

- c. Adjust the zero pressure reading to approximately 100 by turning the calibration screw.
- d. When the A/D count is within the permitted range, press Calibrate.

6.8 Testing Devices

After mapping a device, Trio provides a testing function that enables checking the device's performance.

- Fans: Click Test to test the fan's response.

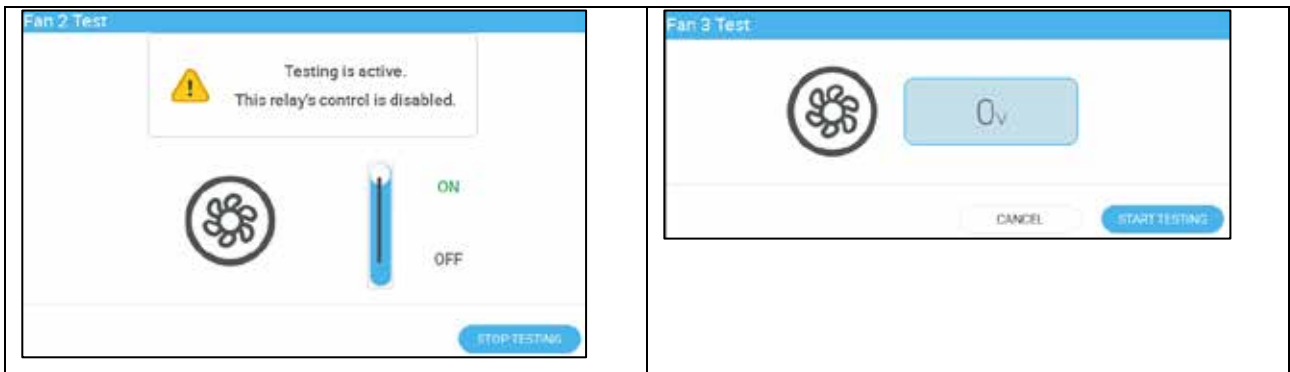

- Relay devices: Click Test > Start Testing to view the relay's status.

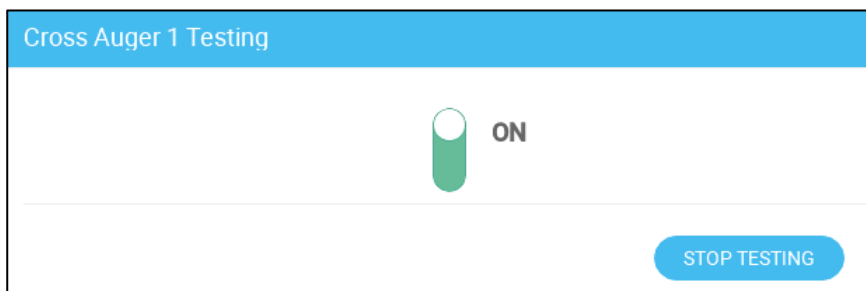

- Analog output devices: Click Test and move the voltage scale to ensure that the device operates at the proper minimum and maximum voltage levels.

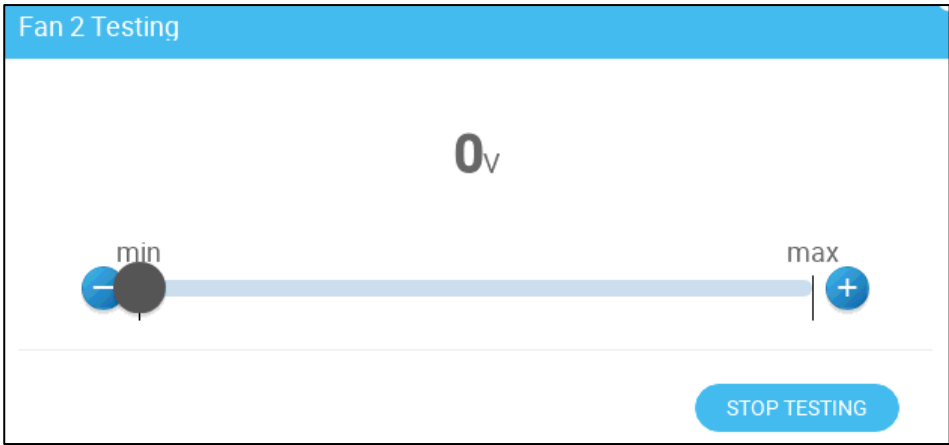

- Analog input devices: Click Test to view the current input results and A2D value. The test function also displays an error message when the input signal is weak or non-existent.

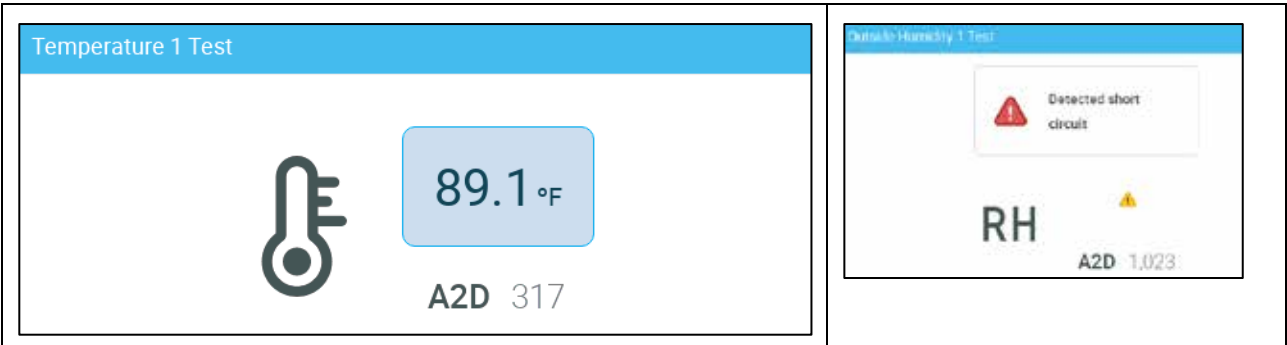

- o Acceptable ranges:
 - § RTS-2: 200 – 600.
- Digital input devices: Click Test to view the current circuit status (signal close or signal open).

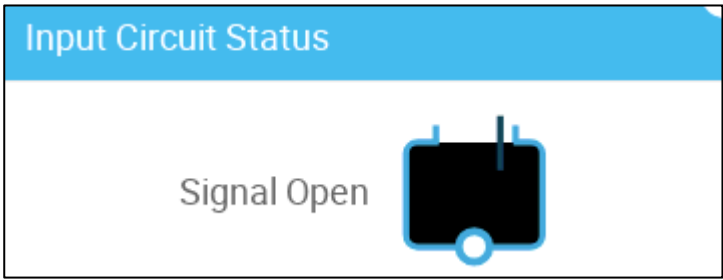

7 Switches

- Relay Types
- Moving the Toggle Switch
- Viewing the Relays' Status

7.1 Relay Types

In the Expansion 70, there are three types of relays:

- Normally Open Relay Cards. In these cards the toggle switches have three statuses:
 - On: The relay remains ON, regardless of the software.
 - Off: The relay remains OFF in any situation.
 - Auto: Trio software controls the relay.
- Normally Close Relay Cards. In these cards the toggle switches have three statuses:
 - On: The relay remains OFF, regardless of the software.
 - Off: The relay remains ON in any situation.
 - Auto: Trio software controls the relay
- Winch Cards. Winch cards drive vents (tunnel doors, inlets, outlets). Two relays are used to control each vent (OPEN and CLOSE).

7.2 Moving the Toggle Switch

In the event that a user moves a toggle switch, a confirmation screen immediately appears:

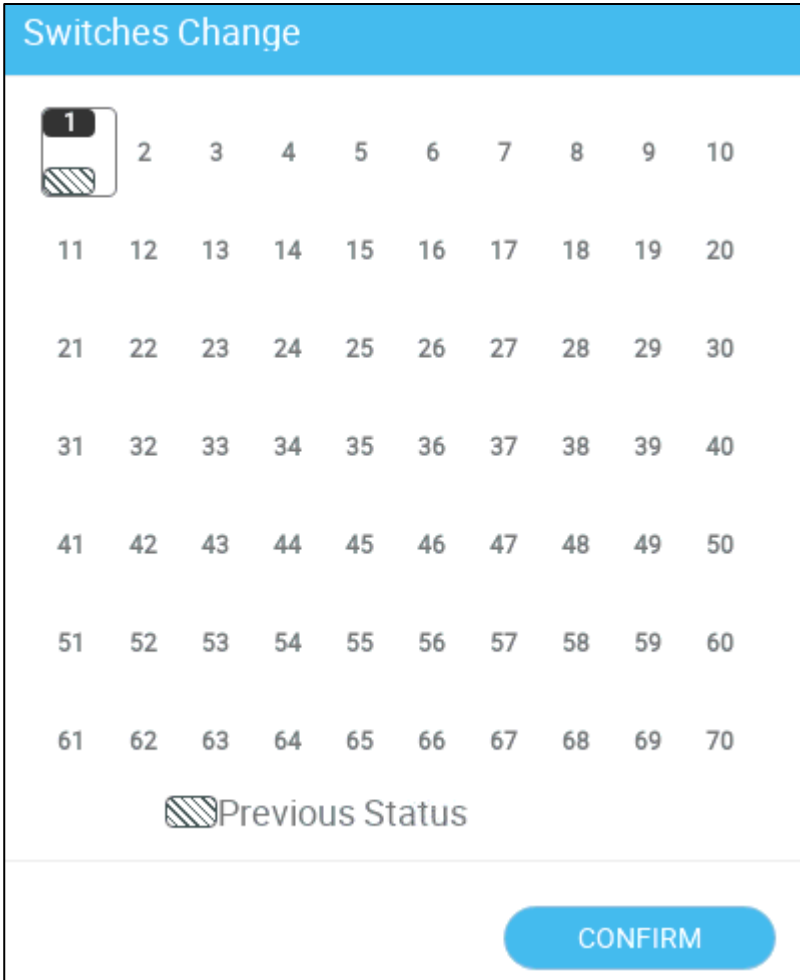

- Click Confirm or move the toggle switch to its previous position.
- If you do not confirm or move the switch within 60 seconds, an alarm is generated.

CAUTION The user needs to confirm the change.

7.3 Viewing the Relays' Status

To view the status of each relay, click the arrow in the Device Icon.

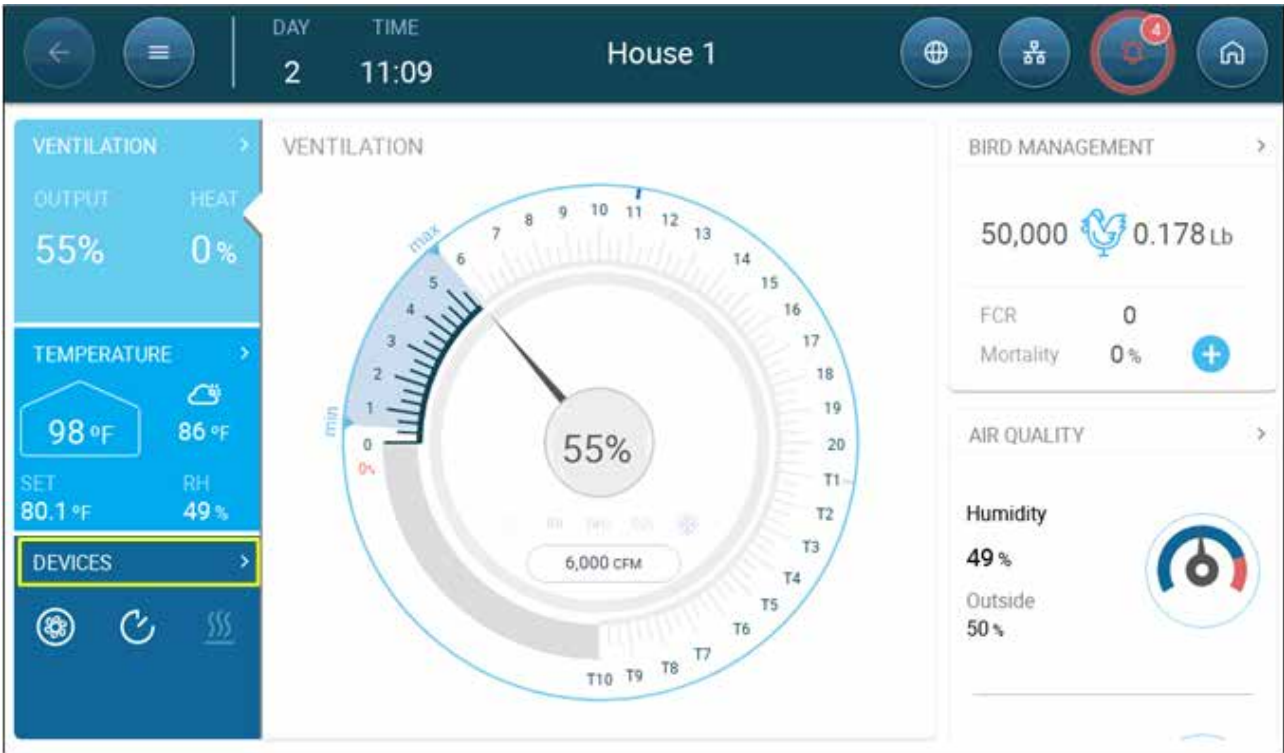

The Relay Status screen appears, showing which relays are set to On, Off, or Auto.

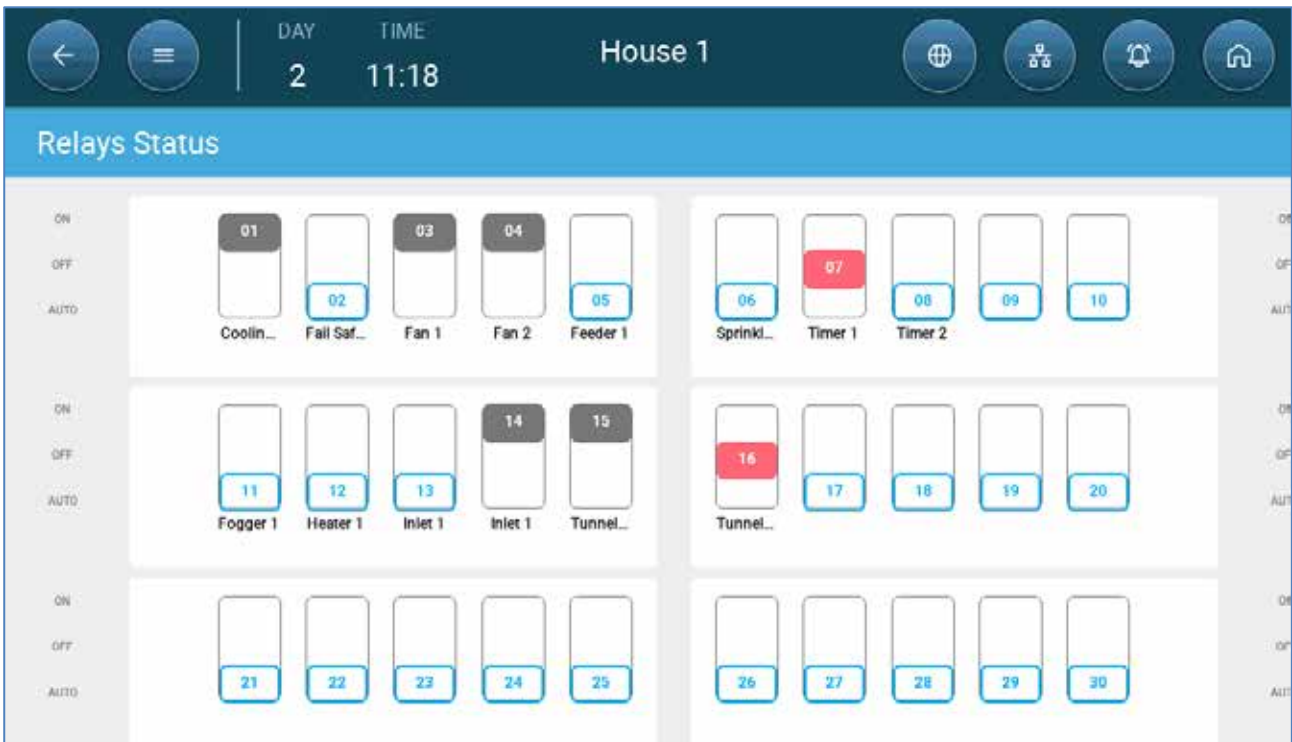

8 Appendix A: Alarm Backup Battery

8.1 General Description

As an option, the Trio Rotem can be equipped with a backup alarm battery. In the event of a power loss, all controller functionality ceases. The backup battery enables Trio to send out SMS messages to the recipients informing them of the power loss. As soon as power is restored, controller functionality restarts. In addition, the battery prevents automatic resets in the event of a very short power outage.

NOTE During a power outage, communication is via the cell modem only.

- A fully powered battery can remain active for five minutes.
- Installation:
 - If the Trio is ordered with the alarm battery, no installation or programming is required.
 - If the battery is ordered as an upgrade, install the unit as shown in Figure 75.

CAUTION Turn off the alarm battery before restarting the Trio. Switch the toggle switch to off. See Figure 75.

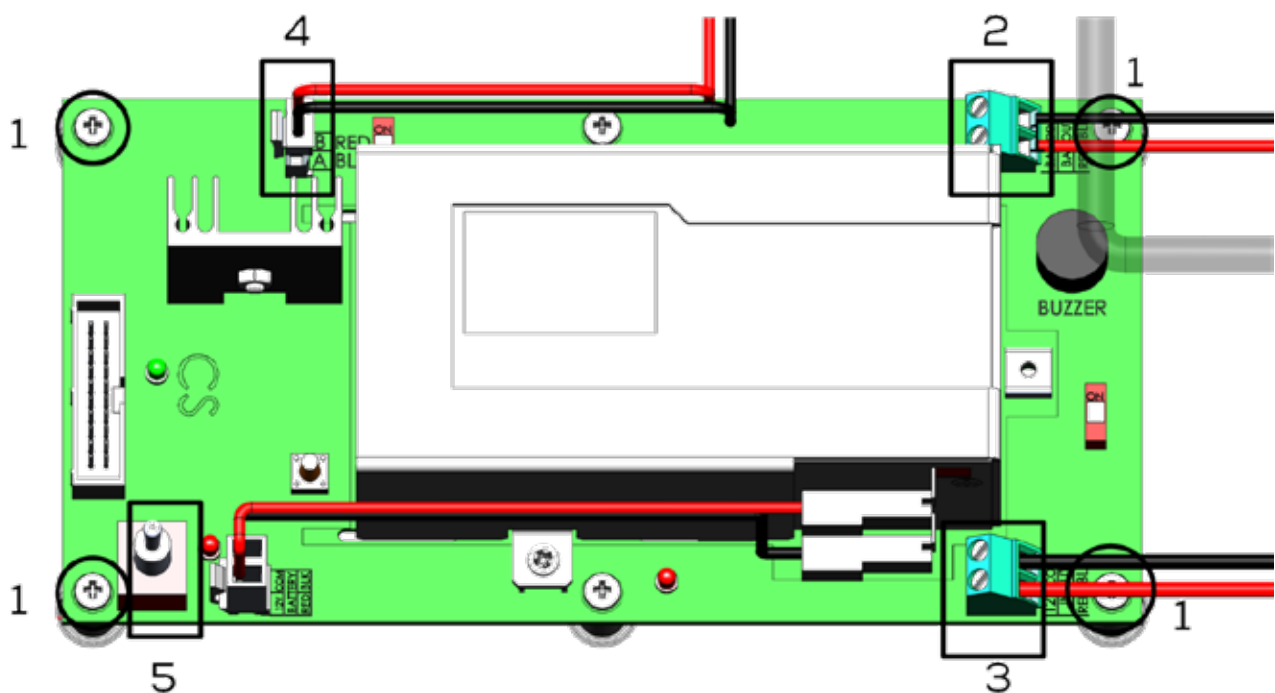

Figure 78: Trio Alarm Battery Installation, Expanded

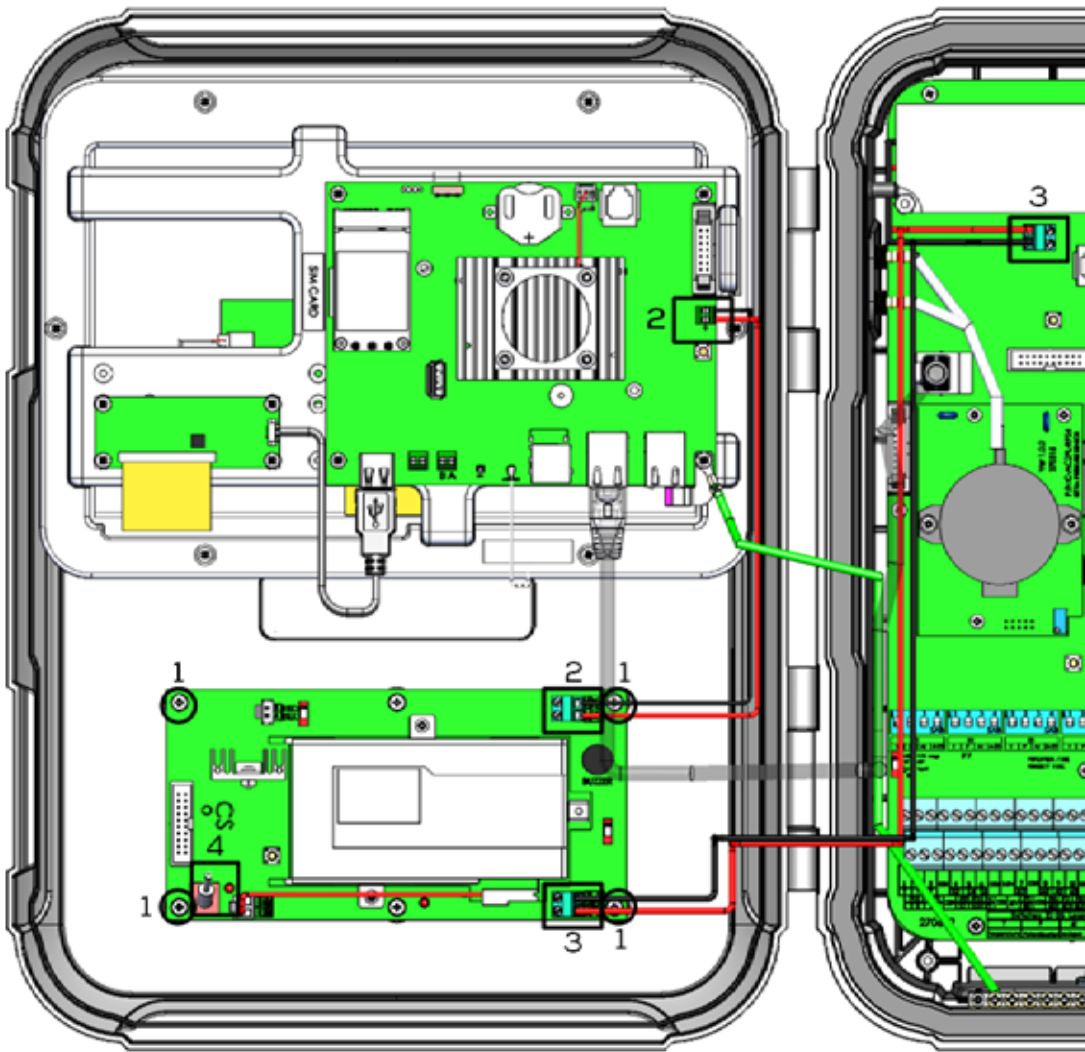

Figure 79: Trio Alarm Battery Installation

1	Attach the card with four screws
2	Attach the wires between the Trio battery and the alarm battery.
3	Attach the wires between the alarm battery and the CPU card.
4	On/off toggle switch

- The toggle switch:
 - When the switch is in the upper position, the battery delivers emergency power to the display card and cell modem when main power is lost.
 - When the switch is in the middle or bottom position, the battery is disconnected from the display card and cell modem; no power is delivered.
 - The LED next to the toggle switch is lit when the switch is in the upper position.

8.2 Detailed Description

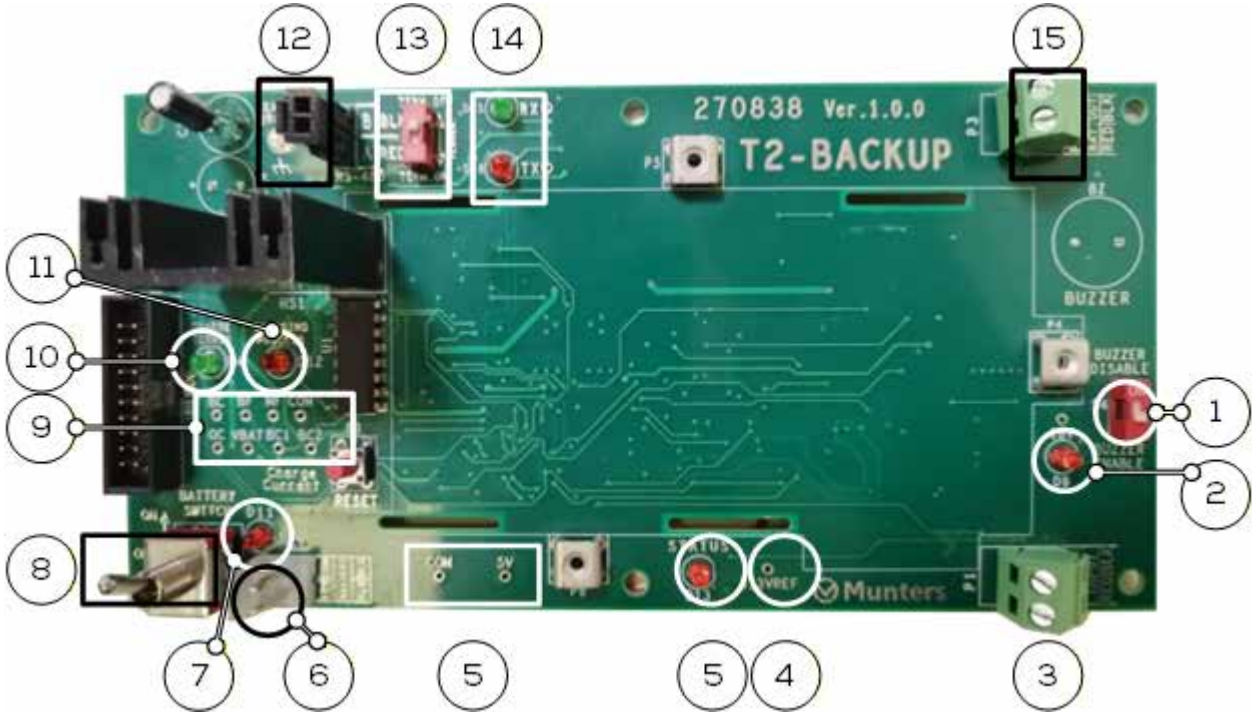

Figure 81: Battery Board Detailed Schematic

##	Component	Functionality	Note
1	Dip switch S4 "BUZZER" Disable/Enable	Restores the battery to working condition after being on a shelf or after transportation	
2	LED D9 "18V"	Indicates the presence of the charger voltage	
3	P1	Input terminal	An input terminal that receives 12V voltage from the motherboard.
4	TP2, TP3	Test points	5V, 3.3VREF (for technicians only)
5	LED D13 "Status"	Indicates the character of the application running	<ul style="list-style-type: none"> Blinks during normal application operation. Remains steadily ON or OFF if the application is stalled.
6	P2	Battery connector	
7	LED D11	Indicates that the battery is connected to the board	

##	Component	Functionality	Note
8	Toggle switch S1 "BATTERY SWITCH"	Connects the battery to the board	During transportation or being on the shelf must be in the state "OFF"
9	Measurements TP1 group	Test points	<ul style="list-style-type: none"> · BC - Battery Current, see below. · BF – Battery Fail, default Low (≤ 150 mV) · MF - Main Fail, default High (4.75-5.0V) · OC - <u>reserve</u> (the Display Card has on its input overcurrent protection device). · VBAT – Battery voltage · BC1-BC2 – Charging battery current (for technicians only)
10	LED D4 "Charge Termin"	Indicates the charging process termination	Lights up when the battery is being discharged by an artificial load and when the battery is fully charged.
11	LED D12 "Charging process"	Indicates the charge/discharge process	<ul style="list-style-type: none"> · High-speed blinking when discharging. · Low-speed blinking when charging. · Turns OFF when charging is completed
12	P8	Communication terminal	RS-485 communication with Display Card
13	DIP Switch S2	Connects termination resistor for RS-485 communication	This DIP switch must be always kept in the position marked "TERM.OFF".
14	N/A		
15	P3	Output terminal	<ul style="list-style-type: none"> · Battery voltage on it appears when a main power 12V outage occurs. · To be connected to Display Card (for technicians only)

8.3 Preparing the Battery for Operation After Transportation or Storage

NOTE Refer to Figure 81 when numbers (#) are mentioned regarding the battery board's components.

1. Apply 12V to the input terminal P1 (#3).
2. Set switch S1 (#8) to the ON position.
3. Move DIP switch S4 (#1) to the ON position.
4. Press the Reset button (refer to #8 in Figure 18: Rotem Trio Controller Display Board Layout, page 33) for 1–2 seconds.
 - LED D12 (#12) begins flashing rapidly (battery is discharging).
 - LED D4 (#10) turns on.
5. Return DIP switch S4 to the OFF position. See Note 1.
 - When the battery voltage reaches 11.9 ± 0.1 V, discharging ceases and the system automatically begins charging the battery. At this point, LED D4 turns off.
 - Charging may take several hours.
 - During charging, LED D12 flashes slowly while the green LED D4 remains off.
 - When the battery is fully charged, LED D12 (#11) turns off and LED D4 (#10) turns on.

Note 1: DIP switch S4 is used to restore batteries that have been unused for a long time (for example, during storage or transport). It works by performing a deep discharge followed by a full recharge, which helps remove buildup on the battery electrodes.

- This process may take 1–4 hours, depending on the battery's condition.
- Use the same procedure when installing a new battery.

9 Appendix B: Service Manual

- Maintenance
- Trouble Shooting
- Spare Parts

9.1 Maintenance

Perform the following steps to maintain your unit.

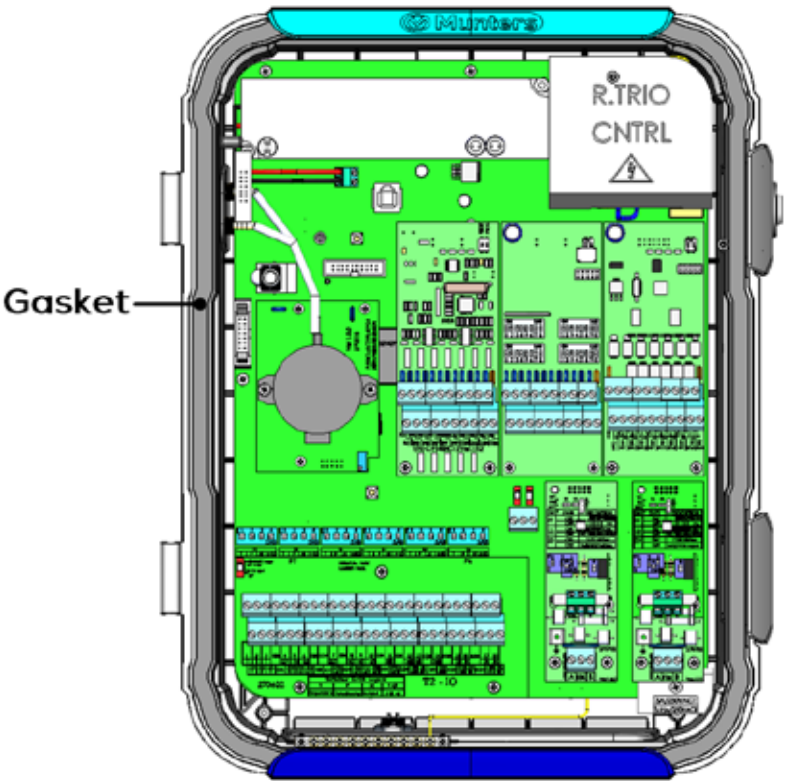
<ul style="list-style-type: none">• Checking the Battery Level: Check the battery once a year. The output must be 2.7 volts (minimum). Authorized personnel only must replace the battery if the output is below the minimum required level or every five years.	
<ul style="list-style-type: none">• Visually inspect your unit once a year. Make sure that there are no signs of corrosion or residue on the PCBs. If these issues appear, it means that:	
<ul style="list-style-type: none"><ul style="list-style-type: none">◦ the Trio is installed in an environment with high humidity, ammonia content, or some other destructive agent.	
<ul style="list-style-type: none"><ul style="list-style-type: none">◦ There is a lack of (silicon) sealing or that the sealing has degraded.	
<ul style="list-style-type: none">• Make sure that the silicon seal around the PGs installed in the knockouts is not cracked.	
<ul style="list-style-type: none">• Check that the gasket is not cracked.	 <p>The diagram shows the internal layout of a Munters Trio unit. It features a green printed circuit board (PCB) populated with various electronic components, including integrated circuits, capacitors, and connectors. A battery is visible on the left side. The PCB is labeled 'R.TRIO CNTRL' with a warning symbol. The unit is housed in a grey frame with a blue gasket around the perimeter. A label 'Gasket' points to this seal. The Munters logo is visible at the top of the frame.</p>

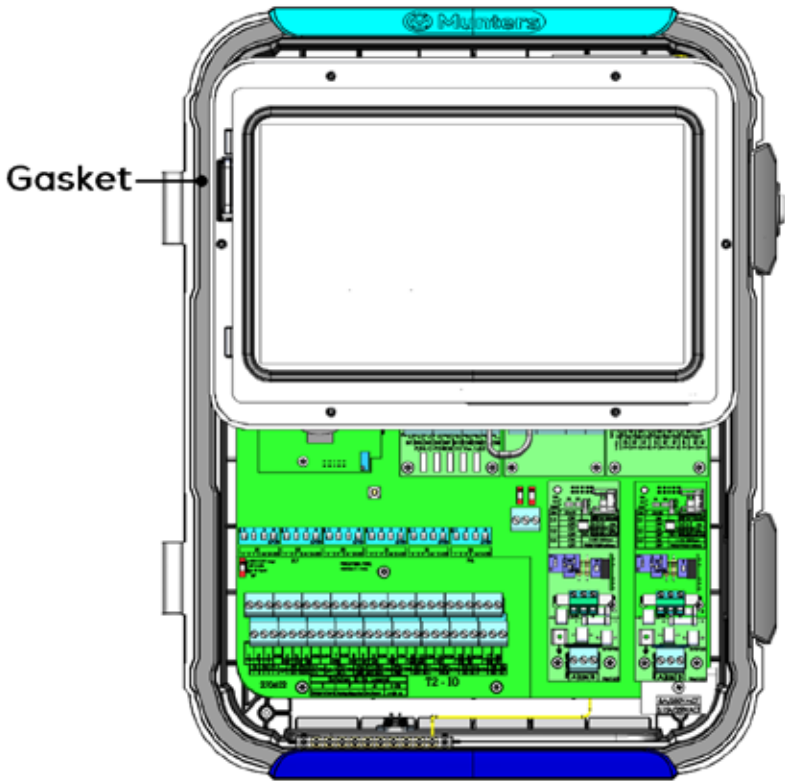
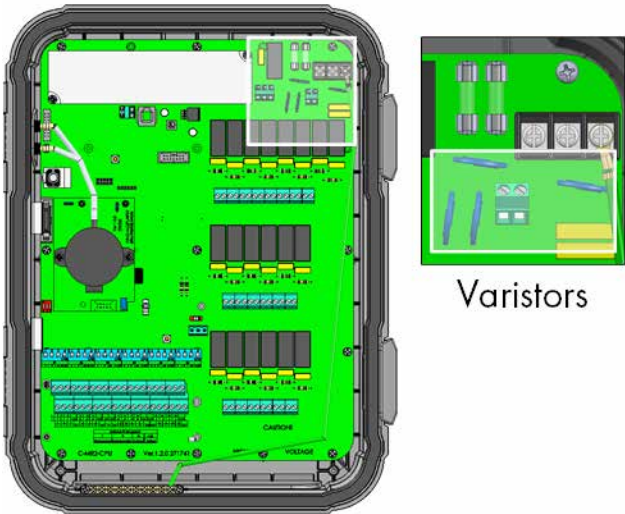
<ul style="list-style-type: none">• Check that the gasket around the touch screen is not cracked.	 <p>A technical diagram of the back cover of a rugged device. The cover is shown in a light grey color. A red rectangular area highlights the gasket around the touch screen opening. A label 'Gasket' with a pointer indicates this area. The device's internal components, including a green PCB and various connectors, are visible through the opening.</p>
<ul style="list-style-type: none">• Look for any signs of burns or browning around the varistors.	 <p>A technical diagram of the device's internal PCB. The PCB is green and populated with various components. A callout box on the right shows a close-up of several varistors, which are small, rectangular components with a yellowish-brown color. The callout is labeled 'Varistors'.</p>
<ul style="list-style-type: none">• Inspect the shield wiring and main grounding cable; ensure that they are properly connected to the proper ports.	

9.2 Trouble Shooting

- Internet
- Electronic Components

9.2.1 INTERNET

The following section describes how to trouble shoot internet problems. In the event that there is no internet connection:

1. Go to System > General Settings > Network Screen. Verify that there is an IP address.
2. Check the cable connections between the switch and the Trio.
3. Verify that the unit is powered.

NOTE If there is no internet connection, the Main Menu Internet icon is marked.



9.2.2 ELECTRONIC COMPONENTS

Problem: The touch screen doesn't turn on up after applying 115/230VAC.

Solution: Open the Trio door and:

1. Check main 115/230VAC 3A fuse F2.
 - If required, replace fuse.
2. Check the 12V terminal voltage (COM & 12V).
 - If there is no voltage, there is a problem with the Switched Power Supply. Replace the power supply.
3. Verify that the 5V and 3.3V indicative LEDs of the I/O power board are lit.
4. Verify that the flat cable connecting the I/O board and the display board is in place.
5. Verify that the Green Status LED is flashing.
6. On the Trio display board, verify that the:
 - RED Status LED is flashing
 - Display's flat cable is firmly hooked up to its connector.

Problem: The screen doesn't reflect changes made in the analog inputs.

Solution:

1. Verify that the position of Dip Switch (S1-S6) corresponds with the relevant analog input.
2. Verify that the analog input terminals' mapping corresponds to the actual wiring.
3. Check that the terminal wire connection of Analog Input of interest coincides with the analog input chosen on the touch screen.

Problem: The screen doesn't reflect the changes in digital inputs.

Solution: Verify that the digital input terminals' mapping corresponds to the actual wiring.

Problem: The Alarm Relay doesn't operate.

Solution: Check fuse F4.

- By default, alarm relay contacts "NO-COM" should be closed.

Problem: The analog output voltage doesn't correspond to the voltage defined on the corresponding analog output terminal.

Solution: Check the load value. The maximum analog output load is 15 mA.

Problem: An analog output terminal has no output voltage.

Solution: Verify that the analog output terminals' mapping corresponds to the actual wiring.

Problem: The display screen appears but does not respond to any touch.

Solution: Check the USB cable between the touch screen card and the Trio display card.

Problem: There is no 3.3V output for to power the potentiometer(s).

Solution: There is a PPTC fuse F1 on the 3.3V line. Disconnect the potentiometers and using a DVM, check the resistance on the terminal between the 12V output and common ground (COM). The reading should indicate an open circuit.

- If not, the line is damaged.

Problem: The end user doesn't see changes in the data tables.

Solution:

1. Check the Internet cable, going from RJ-45 connector (marked as Ethernet-2). Verify that the connector's LEDs are flashing.
2. Check the Internet cable, going from the power card to the Trio display's card RJ-45 connector (marked as Ethernet-1). Verify that the connector's LEDs are flashing.

9.3 Spare Parts

- Preliminary Information
- Rotem Trio Minimal Spare Parts
- Rotem Trio Controller
- Rotem Trio Expansion 70
- Additional Options
- Cards

9.3.1 PRELIMINARY INFORMATION

Table 12: Table Key

	Rotem Trio Controller	Rotem Trio Expansion 70
Container	A	E
Door Cards	B	F
Main Container Cards	C	G
Cables and Harnesses	D	H
MPN	Munters Part Number	
DPN	Distributor Part Number	

9.3.2 ROTEM TRIO MINIMAL SPARE PARTS

Munters Israel recommends that managers of farms equipped with Trio Controllers keep (as a minimum stock) the following spare parts on hand. Doing so simplifies maintenance and repairs of the Trio units.

Table 13: Parts for Rotem Trio Controller

P/N	Description
940-99-00002	TRIO-20 LCD KIT (DISPLAY + LVDS CARD + USB CABLE) (SP-250061)
999-99-00386	BAT COIN 3V FOR SOCKET (SP-450009)
940-99-00162	ROTEM TRIO-POU-EN DISPLAY CARD IMX8 NEXCOM
940-99-00177	FAN 12V 0.62W 7000RPM 8CFM (SP-240201)
940-99-00035	TRIO 20 ANTENNA WIFI MOLEX 15cm CABLE U.FL/I-PEX MHF 2.4GHz 2.8dBi 50ohm (SP-491009)
940-99-00144	ROTEM TRIO HIGH VOLTAGE POWER INPUT CARD (T2-HV)

Table 14: Parts for Rotem Trio Switch

P/N	Description
940-99-00060	ROTEM TRIO RS485 EXPANSION CARD (T2-SC-MASTER)
940-99-00151	ROTEM TRIO NO10 CURRENT SENSE SWITCH CARD
940-99-00171	ROTEM TRIO WC10 CURRENT SENSE WINCH SWITCH CARD
900-99-00227	ONE / ONE PRO - POWER SUPPLY 150W LOW VOLTAGE (P4-PS-LV)

P/N	Description
900-99-00226	ELG-150-12A 150W SINGLE OUTPUT PFC 12V 10A IP65 Mean Well (SP-370191)
900-99-00225	ONE / ONE PRO - POWER SUPPLY 150W HIGH VOLTAGE (P4-PS-HV)
940-99-00155	ROTEM TRIO NO5 30A CURRENT SENSE RELAY CARD (T2-NO5-CS-RC)
940-99-00170	ROTEM TRIO WC5 30A CURRENT SENSE WINCH RELAY CARD

9.3.3 ROTEM TRIO CONTROLLER

- Rotem Trio Controller Container Spare Parts
- Rotem Trio Controller Door Card Spare Parts
- Rotem Trio Controller Main Container Spare Parts



9.3.3.1 Rotem Trio Controller Container Spare Parts

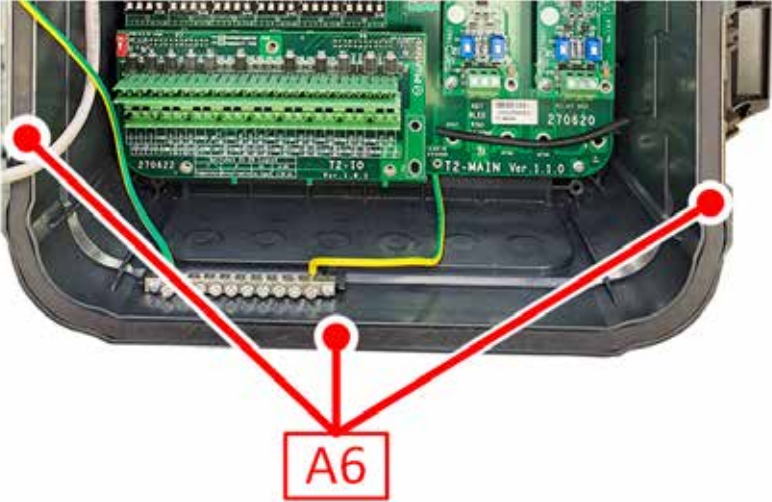

ID No.	Description	Catalog Number	Note
A1.1	TRIO-20 FRONT DOOR TOUCH PLASTIC PART	MPN: 940-99-00005	
		DPN:	
A1.2	TRIO-20 PLASTIC BOX BASE (SP – 207124)	MPN: 940-99-00112	
		DPN:	
A1.3	TRIO HINGE PLASTIC PIN V1.0.0 (SP-207128)	MPN: 940-99-00019	
		DPN:	
A2.1	TRIO-20 PANEL PLASTIC PART BLUE LOGO MUNTERS + PART BLUE	MPN: 940-99-00001	OR
		DPN:	
A2.2	TRIO PANEL PLASTIC PART RED RAL 3020 NO LOGO (SP-207138)	MPN: 940-99-00045	
		DPN:	
A3.1	ONE / ONE PRO - LATCH GENERAL LOCK PLASTIC PART + LOCK FOR LATCH	MPN: 900-99-00217	
		DPN:	
A3.2	GENERAL PLASTIC LATCH	MPN: 900-99-00216	
		DPN:	
A4	TRIO-20 LCD HOLDER V1.0.0 (SP-207125)	MPN: 940-99-00024	
		DPN:	
A5	P4 SCREEN GASKET SILICONE 35 SHORE 75CM (EXTRUSION PROCESS) (SP-204079)	MPN: 940-99-00020	
		DPN:	
A6	MID-RANGE MAIN GASKET V1.0.0 (SP-207122)	MPN: 940-99-00021	
		DPN:	

9.3.3.2 Rotem Trio Controller Door Card Spare Parts

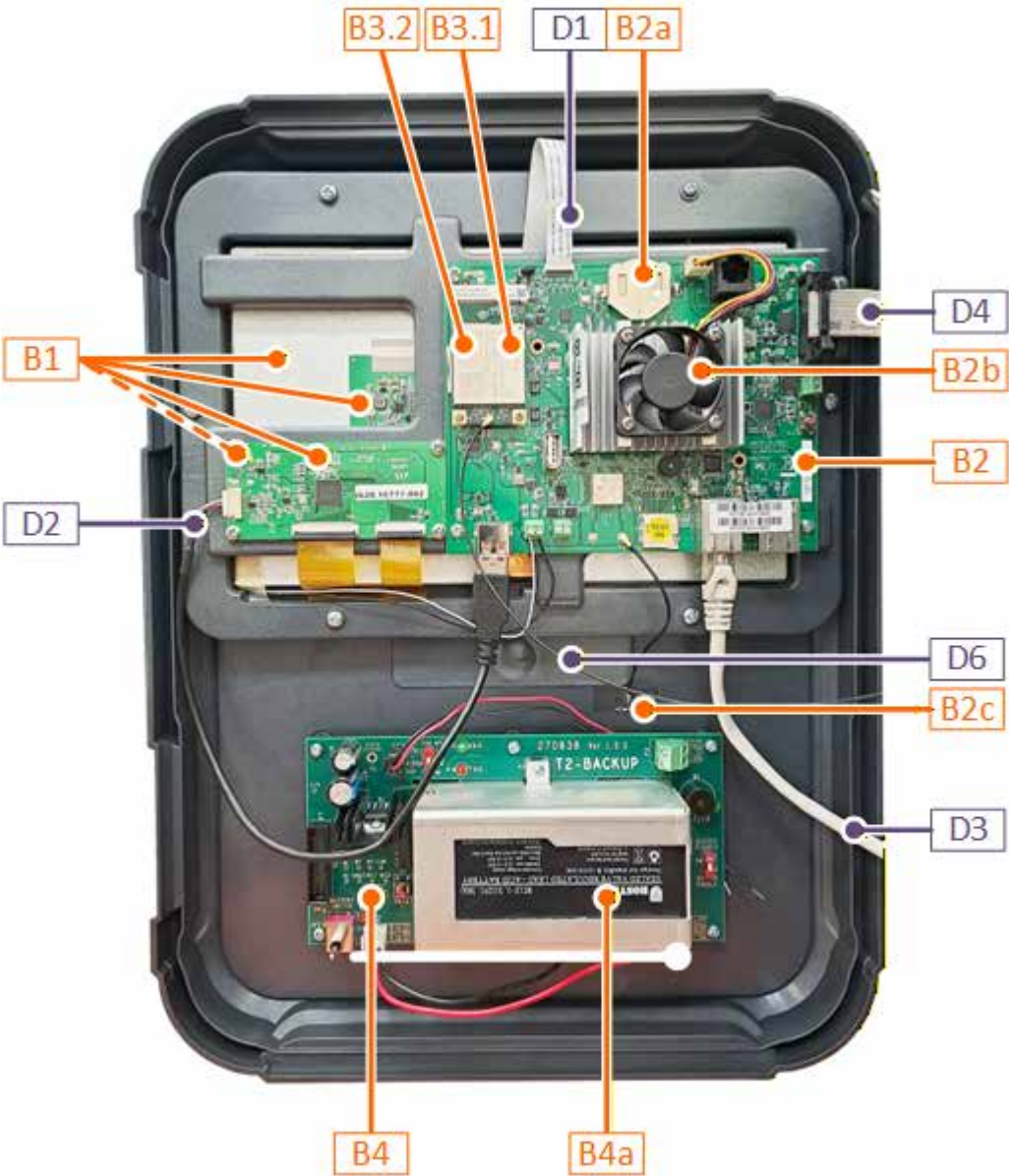

ID No.	Description	Catalog Number
B1	TRIO-20 LCD KIT (DISPLAY + LVDS CARD), [+ USB CABLE *	MPN: 940-99-00002
		DPN:
B2	ROTEM TRIO-POU-EN DISPLAY CARD IMX8 NEXCOM	MPN: 940-99-00162
		DPN:
B2a	BAT COIN 3V FOR SOCKET (SP-450009)	MPN: 999-99-00386
		DPN:
B2b	FAN 12V 0.62W 7000RPM 8CFM (SP-240201)	MPN: 940-99-00177
		DPN:
B2c	TRIO 20 ANTENNA WIFI MOLEX 15cm CABLE U.FL/I-PEX MHF 2.4GHz 2.8dBi 50ohm (SP- 491009)	MPN: 904-99-00035
		DPN:
B3.1	GLOBAL LTE CELL MODEM W/O SIM SOCKET- EG21GGB-MINIPCIE (SP-490099)	MPN: 904-99-00106
		DPN:
B3.2	Trio Cell Modem Global SIM (SP-221011)	MPN: 904-99-00118
		DPN:
B4	TRIO HIGH RANGE POWER BACKUP CARD (T2-BACKUP)	MPN: 940-99-00167
		DPN:
B4a	BAT Pb 12V 1.2AH NP12-1.2AH NPP (SP-450042)	MPN: 940-99-00178
		DPN:

ID No.	Description	Catalog Number
D1	VIDEO FLAT CABLE 0.02" (0.50 mm) Type 1,152.4 mm	MPN: 940-99-00012
		DPN:
D2	USB CABLE FOR Vitek\Ampire DISPLAY (SP- 140672)	MPN: 940-99-00027
		DPN:
D3	NETWORK CABLE RJ485 (8 WIRES, 0.5 METERS)	MPN: 940-99-00011
		DPN:
D4	FLAT FF14P 25CM F"D>_V1.0.0 (SP-141161)	MPN: 999-99-00457
		DPN:
D5	ROTEM TRIO CONTROL UNIT COMMUNICATION CABLE (SP-143123)	MPN: 940-99-00145
		DPN:

ID No.	Description	Catalog Number
D6	CABLE GSM 40cm M.SMA-UFL (SP-490008)	MPN: 940-99-00036
		DPN:

9.3.3.3 Rotem Trio Controller Main Container Spare Parts

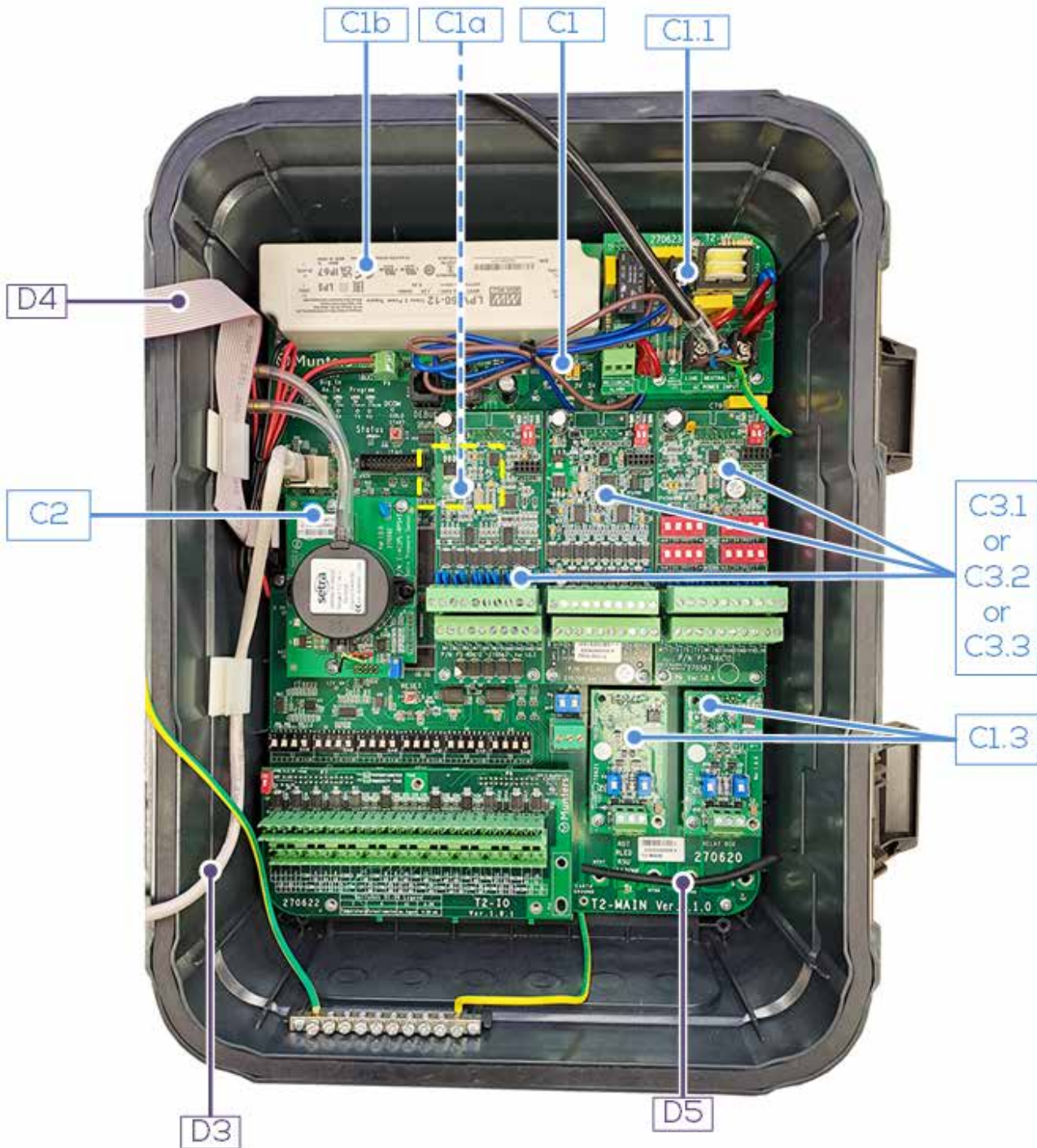

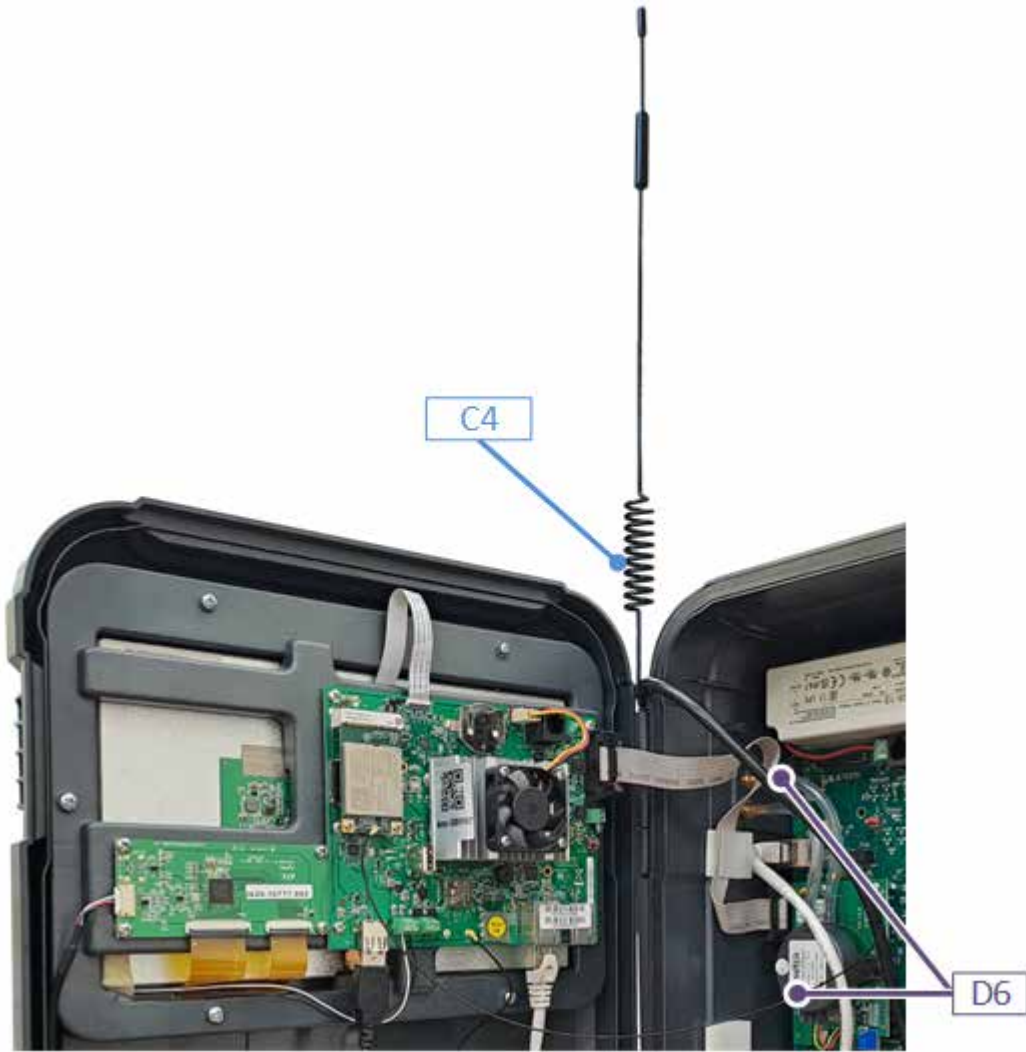

ID No.	Description	Catalog Number	Remarks
C1	ROTEM TRIO CONTROL UNIT MAIN CARD SET	MPN: 940-99-00137 DPN:	
C1a	BAT COIN 3V FOR SOCKET (SP-450009)	MPN: 999-99-00386 DPN:	
C1b	TRIO 20 POWER SUPPLY 100-240V 12V 60W (SP-370193)	MPN: 940-99-00136 DPN:	
C1.1	ROTEM TRIO HIGH VOLTAGE POWER INPUT CARD (T2-HV)	MPN: 940-99-00144 DPN:	
C1.2	ROTEM TRIO I/O CARD (T2-IO)	MPN: 940-99-00146 DPN:	
C1.3	ROTEM TRIO / OPTI-ZONE RS485 COMMUNICATION CARD (T2/OZ-RS485)	MPN: 940-99-00147 DPN:	

ID No.	Description	Catalog Number	Remarks
C2	STATIC PRESSURE SET - AC3G/SE/PL/TRIO -POU	MPN: 901-99-00025	
		DPN:	
C3.1	TRIO 20 SCALE CARD 6SCL (TRIO-RSC-6)	MPN: 940-99-00014	OR
		DPN:	
C3.2	ROTEM TRIO (T2) DIGITAL INPUT CARD (T2-RDIC12)	MPN: 940-99-00142	OR
		DPN:	
C3.3	ROTEM TRIO (T2) ANALOG INPUT CARD (T2-RAIC12)	MPN: 940-99-00143	
		DPN:	
C4	ANTENNA 699-2690MHz 3.2dBi 500HM MAGNETIC WITH MOUNTING BRACKET 2G/3G/4G (SP-491010)	MPN: 940-99-00039	
		DPN:	

9.3.4 ROTEM TRIO EXPANSION 70

- Rotem Trio Expansion 70 Container Spare Parts
- Rotem Trio Expansion 70 Cards Spare Parts
- Rotem Trio Expansion 70 Main Container Cards Spare Parts



9.3.4.1 Rotem Trio Expansion 70 Container Spare Parts

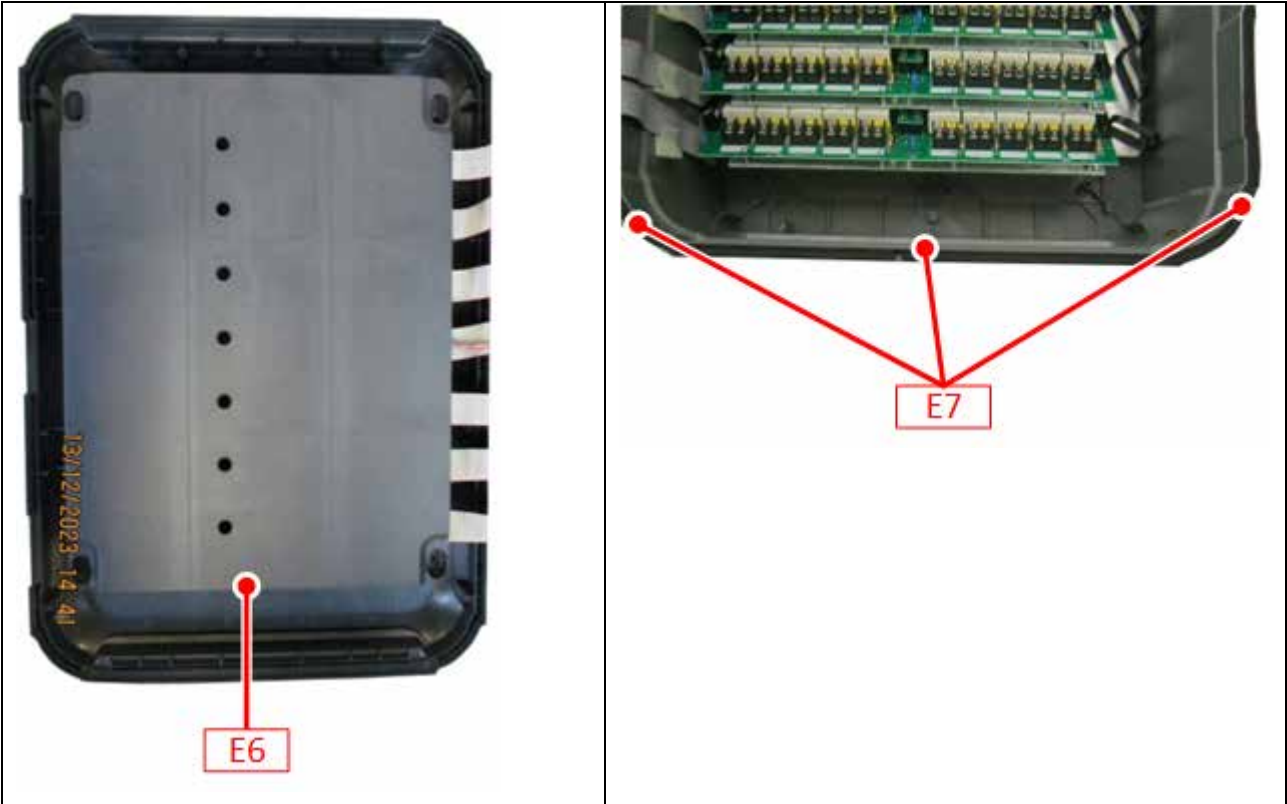

ID No.	Description	Catalog Number
E1.1	FRONT DOOR TRIO HIGH-RANGE T2	MPN: 940-99-00148
		DPN:
E1.2	ONE / ONE PRO - BOX BASE PLASTIC PART (SP-207111)	MPN: 900-99-00212
		DPN:
E1.3	ONE / ONE PRO - HINGE PIN MAIN (SP-204085)	MPN: 900-99-00213
		DPN:
E2	PLASTIC TRANSPARENT DOOR + TWO HINGE PINS	MPN: 940-99-00149
		DPN:
E3	ONE / ONE PRO - PANEL PLASTIC PART BLUE LOGO MUNTERS + PART BLUE	MPN: 900-99-00215
		DPN:
E4	ONE / ONE PRO - LATCH GENERAL PLASTIC PART (SP-207112)	MPN: 900-99-00216
		DPN:
E5	ONE / ONE PRO - LATCH GENERAL LOCK PLASTIC PART + LOCK FOR LATCH	MPN: 900-99-00217
		DPN:
E6	PLASTIC COVER FOR SWITCH CARDS (SP-207148)	MPN: 940-99-00150
		DPN:
E7	P4 MAIN GASKET SPONGE EPDM 50 SHORE (PRESSING PROCESS) (SP-203013)	MPN: 900-99-00370
		DPN:

9.3.4.2 Rotem Trio Expansion 70 Cards Spare Parts



ID No.	Description	Catalog Number	Remarks
F1.1	ROTEM TRIO NO10 CURRENT SENSE SWITCH CARD	MPN: 940-99-00151	OR
		DPN:	
F1.2	ROTEM TRIO WC10 CURRENT SENSE WINCH SWITCH CARD	MPN: 940-99-00171	
		DPN:	
F2	ROTEM TRIO SWITCH BUS (T2-SW-BUS)	MPN: 940-99-00061	
		DPN:	
F3	ROTEM TRIO RS485 EXPANSION CARD (T2-SC-MASTER)	MPN: 940-99-00060	
		DPN:	

ID No.	Description	Catalog Number	Remarks
H1	FLAT FF24P 30cm V1.0.0 (SP-141008)	MPN: 940-99-00152	
		DPN:	
H2	FLAT FF14P 31CM(DU1)<F"D_F"D> (SP-141157)	MPN: 999-99-00536	
		DPN:	
H3	ONE / ONE PRO - MULTI CABLE 45CM 4X18 AWG-90 (SP-143081)	MPN: 900-99-00222	
		DPN:	
H4	CABLE TRIO SWITCH UNIT WEIPU M-SP1312-52CM (SP-143124)	MPN: 940-99-00153	
		DPN:	
H5	CABLE ROTEM TRIO L=1M WEIPU M-SP1310-100CM (SP-143125)	MPN: 940-99-00154	Not shown in picture above
		DPN:	

9.3.4.3 Rotem Trio Expansion 70 Main Container Cards Spare Parts

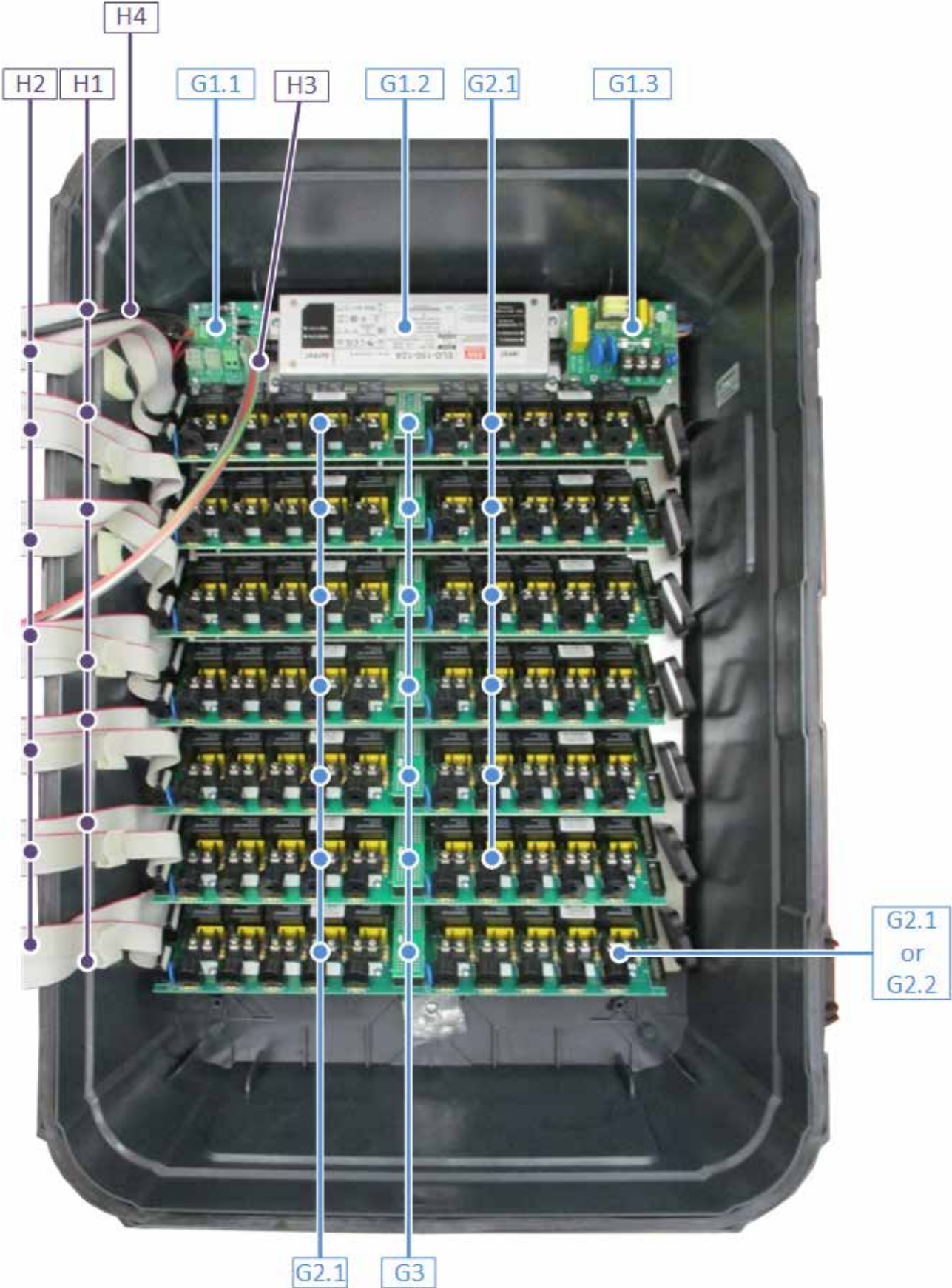

ID No.	Description	Catalog Number	Remarks
G1.1	ONE / ONE PRO - POWER SUPPLY 150W LOW VOLTAGE (P4-PS-LV)	MPN: 900-99-00227	
		DPN:	
G1.2	ELG-150-12A 150W SINGLE OUTPUT PFC 12V 10A IP65 Mean Well (SP-370191)	MPN: 900-99-00226	
		DPN:	
G1.3	ONE / ONE PRO - POWER SUPPLY 150W HIGH VOLTAGE (P4-PS-HV)	MPN: 900-99-00225	
		DPN:	
G2.1	ROTEM TRIO NO5 30A CURRENT SENSE RELAY CARD (T2-NO5-CS- RC)	MPN: 940-99-00155	OR
		DPN:	
G2.2	ROTEM TRIO WC5 30A CURRENT SENSE WINCH RELAY CARD	MPN: 940-99-00170	
		DPN:	
G3	ROTEM TRIO RELAY JUMPER CARD (T2-RC-JMP)	MPN: 940-99-00156	
		DPN:	

9.3.5 ADDITIONAL OPTIONS

ID No.	Description	Catalog Number	Remarks
ADO 1	ROTEM TRIO N.O CURRENT SENSE SWITCH & RELAY CARDS SET	MPN: 940-99-00059	
		DPN:	
ADO 2	ROTEM TRIO SWITCH PANEL CURRENT SENSE WINCH RELAY & SWITCHES SET	MPN: 940-99-00172	
		DPN:	
ADO 3	TRIO GLOCAL LTE CELL MODEM & EXTERNAL ANTENNA SET	MPN: 940-99-00049	
		DPN:	
ADO 4	TRIO DISPLAY CARD BACKUP BATTERY KIT	MPN: 940-99-00176	
		DPN:	
ADO 5	RTS 2 - TEMPERATURE SENSOR - TYPE 2 BLACK CVILUX	MPN: 918-01-00001	
		DPN:	
ADO 6.1a	RHS10 HUMIDITY SENSING TIP SE (SP- RHS10-TIP-SE)	MPN: 999-99-00214	For +/-SE Sensor
		DPN:	
ADO 6.2	HUMIDITY SENSOR-RHS-PRO-POU-MUR	MPN: 917-04-10001	
		DPN:	

ID No.	Description	Catalog Number	Remarks
ADO 6.2a	HUMIDITY SENSOR PRO TIP - (RHS-PRO-TIP)	MPN: 917-99-10002	For Pro Sensor
		DPN:	
ADO 7	STATIC PRESSURE SET - AC3G / SE / PL / TRIO - POU (WITH EXTERNAL TUBE)	MPN: 901-99-00025	
		DPN:	
ADO 7a	TUBES AND FILTERS FOR RPS (NO RPS CARD)	MPN: 999-99-00503	
		DPN:	
ADO 8	CO2-POU-EN-MUR	MPN: 919-03-10001	
		DPN:	
ADO 9.1	TRIO 20 SCALE CARD 2SCL WITH 230V POWER SUPPLY	MPN: 940-99-00015	OR
		DPN:	
ADO 9.2	TRIO 20 SCALE CARD 6SCL WITH 230V POWER SUPPLY	MPN: 940-99-00016	OR
		DPN:	
ADO 9.3	TRIO 20 SCALE CARD 2SCL WITH 115V POWER SUPPLY	MPN: 940-99-00017	OR
		DPN:	
ADO 9.4	TRIO 20 SCALE CARD 6SCL WITH 115V POWER SUPPLY	MPN: 940-99-00018	
		DPN:	
ADO 10	AMMONIA-POU-MUN	MPN: 929-01-00002	
		DPN:	
ADO 11	LIGHT SENSOR-RLS-1-40 LUX-POU	MPN: 928-01-00002	
		DPN:	





9.3.6 CARDS





- Rotem Trio Controller Cards & Accessories
- Rotem Trio Expansion 70 Cards and Accessories

9.3.6.1 Rotem Trio Controller Cards & Accessories



- Door Cards
- Main Container Cards
- Cables and Harnesses





9.3.6.1.1 Door Cards

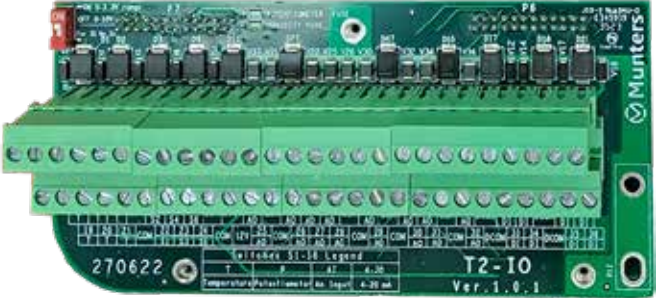

Card	Description	Catalog Number
	<p>250061: LCD TFT 10.1' VT101C-KC17- B07A Vitek</p>	<p>940-99-00002</p>
	<p>140672: CABLE USB FOR APEX\VITEK (250061) DISPLAY</p>	<p>940-99-00027</p>
	<p>208027:TRIO- DISPLAY PC BOARD IMX8 NEXCOM</p>	<p>940-99-00162</p>
	<p>491009: ANTENNA WIFI MOLEX 15cm CABLE U.FL/I-PEX MHF 2.4GHz 2.8dBi 50ohm/YFO026AA Quectel</p>	<p>940-99-00035</p>

Card	Description	Catalog Number
 <p>QUECTEL EG21-G Q1-A5967 GB EG21GGB-128-SGNS CE TA-2019-985 APPROVED R-C-DUT-EG21-G ANATEL 02028-19-07960 INTEL RT Q1-EG18-0427-A1 TCC 17XMP201806E021G C-103946-201806E021G S-110-Q32A-00700-8318 M-110-11041-458941</p>	<p>490099: QUECTEL GLOBAL LTE CELL MOD EM W/O SIM SOCKET- EG21GGB- MINIPCIE</p>	<p>904-99-00106</p>
 <p>WEBBING Streaming global data connectivity webbingpou.com</p>	<p>221011: TRIO CELL MODEM GLOBAL SIM</p>	<p>904-99-00118</p>
 <p>ROSTEC SEALD VALVE REGULATED LEAD-ACID BATTERY Design for standby & cycle use Capacity: 1.2Ah (20°C) Voltage: 12V (20°C) Cycle life: 1000 cycles Max. discharge rate: 0.2C Caution: Do not short-circuit terminals</p>	<p>TRIO HIGH RANGE POWER BACKUP CARD (T2-BACKUP)</p>	<p>940-99-00167</p>
 <p>ROSTEC SEALD VALVE REGULATED LEAD-ACID BATTERY Design for standby & cycle use Capacity: 1.2Ah (20°C) Voltage: 12V (20°C) Cycle life: 1000 cycles Max. discharge rate: 0.2C Caution: Do not short-circuit terminals</p>	<p>450042: BAT Pb 12V 1.2AH NP12- 1.2AH NPP</p>	<p>940-99-00178</p>





9.3.6.1.2 Main Container Cards

Card	Description	Catalog Number
 <p>The image shows a green printed circuit board (PCB) for a control unit. At the top left, there is a white power supply unit labeled 'LPV-60-12'. The board is populated with various electronic components, including integrated circuits, capacitors, and resistors. Two circular potentiometers are visible in the center. On the right side, there are two sets of terminal blocks labeled 'SCALE DIG. INPUT' and 'SCALE AN. INPUT'. At the bottom, there is a large multi-pin connector. The board is marked with 'T2-10 Ver. 1.1.0' and 'T2-MAIN Ver. 1.1.0'.</p>	<p>ROTEM TRIO CONTROL UNIT MAIN CARD SET</p>	<p>940-99-00137</p>
 <p>The image shows a white rectangular power supply unit. The label on the front reads 'LPV-60-12 Class 2 Power Supply' and '100-240V 12V 60W'. It features several safety and compliance logos, including CE, IP67, and LPS. Red, black, and blue wires are connected to the terminals on the right side.</p>	<p>370193: -60-12 Mean Well 100-240V 12V 60W</p>	<p>940-99-00136</p>
 <p>The image shows a green PCB labeled 'T2-HV'. It features a large yellow toroidal transformer in the center. Below the transformer are several terminal blocks for 'AC POWER INPUT', with labels for 'LINE', 'NEUTRAL', and 'GND'. There are also terminals for 'LINE', 'NEUTRAL', and 'GND' on the left side. A red terminal block is labeled 'NO COMMON ALARM'. The board is marked with '270623' and 'Munters'.</p>	<p>R-T2-HV: ROTEM TRIO HIGH VOLTAGE POWER INPUT CARD</p>	<p>940-99-00144</p>

Card	Description	Catalog Number
 <p>A green printed circuit board (PCB) with a Munters logo on the right side. It features a long green terminal block with 24 pins. The board is labeled '270622', 'T2-IO', and 'Ver. 1.0.1'.</p>	R-T2-IO: ROTEM TRIO I/O CARD	940-99-00146
 <p>A green PCB with a green terminal block on the left. It has several electronic components, including a red component and a black component. The board is labeled '270621 T2-RS485'.</p>	R-T2/OZ- RS485: ROTEM TRIO / OPTI- ZONE RS485 COMMUNICAT ION CARD	940-99-00147
 <p>A green PCB with a circular sensor component labeled 'setra'. A long, clear plastic tube is connected to the sensor. Below the PCB is a coiled clear plastic tube with a black tie-wrap.</p>	STATIC PRESSURE SET - AC3G/SE/PL/T RIO-POU	901-99-00025
 <p>A coiled clear plastic tube with a black tie-wrap, similar to the one in the previous row.</p>	TUBES AND FILTERS FOR RPS (NO RPS CARD)	999-99-00503
 <p>A green PCB with a green terminal block on the left. It has several electronic components, including a black component and a red component. The board is labeled 'P/N: C-03-RSC', '270709', and 'Ver.10.1'.</p>	R-TRIO-RSC-6: TRIO 20 SCALE CARD 6CH	940-99-00014

Card	Description	Catalog Number
	R-T2-: ROTEM TRIO (T2) DIGITAL INPUT CARD	940-99-00142
	R-T2-RAIC12: ROTEM TRIO (T2) ANALOG INPUT CARD	940-99-00143
	ANTENNA 699-2690MHz 3.2dBi 50OHM MAGNETIC 2G/3G/4G (SP-491010)	940-99-00039





9.3.6.1.3 Cables and Harnesses

Card	Description	Catalog Number
	141182: FLAT 20 Position FFC Cable 0.02"(0.50mm),Type 1,152.4mm UP-DOWN CONNECTOR SIDE	940-99-00012
	140195: NETWORK CABLE RJ45 8 WIRES CAT5E 0.5 METERS	940-99-00011
	141161: FLAT FF14P 25CM F"D>_F"D> V1.0.0	999-99-00457
	143123: CABLE ROTEM TRIO CONTROL UNIT WEIPU M-SP1312-22CM	940-99-00145
	490008: CABLE GSM 40CM M.SMA-UFL	940-99-00036



9.3.6.2 Rotem Trio Expansion 70 Cards and Accessories



- Door Cards
- Main Container Cards
- Cables and Harnesses

9.3.6.2.1 Door Cards

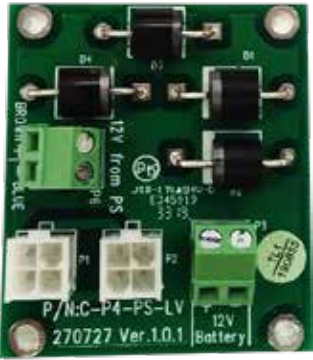
Card	Description	Catalog Number
	R-T2-NO10-CS-SC: ROTEM TRIO NO10 CURRENT SENSE SWITCH CARD	940-99-00151
	ROTEM TRIO WC10 CURRENT SENSE WINCH SWITCH CARD	940-99-00171
	R-T2-SW-BUS: ROTEM TRIO SWITCH BUS CARD	940-99-00061
	R-T2-SC-MASTER: ROTEM TRIO SWITCH MASTER CARD	940-99-00060

9.3.6.2.2 Main Container Cards

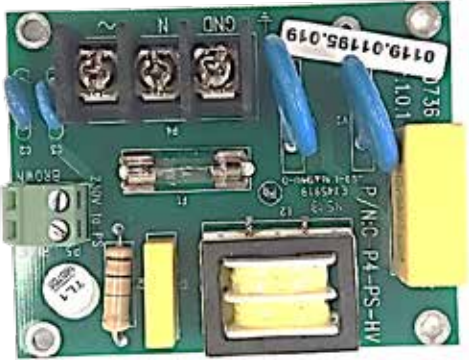
Card	Description	Catalog Number
	R-P4-PS-LV: P4 POWER SUPPLY 150W LOW VOLTAGE	900-99-00227
	SWPS ELG-150-12A 150W SINGLE OUTPUT 12V 10A	900-99-00226

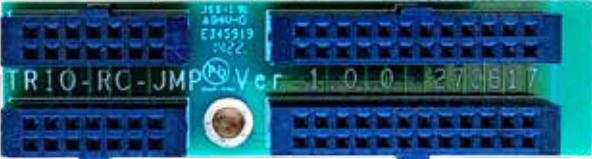
Card	Description	Catalog Number
	R-P4-PS-HV: P4 POWER SUPPLY 150W HIGH VOLTAGE	900-99-00225
	R-T2-NO5-CS-RC: ROTEM TRIO N.O CURRENT SENSE SWITCH CARD	940-99-00155
	ROTEM TRIO WC5 30A CURRENT SENSE WINCH RELAY CARD	940-99-00170
	R-T2-RC-JMP: ROTEM TRIO RELAY JUMPER CARD	940-99-00156

9.3.6.2.3 Cables and Harnesses

Card	Description	Catalog Number
	141008: FLAT FF24P 30cm V1.0.0	940-99-00152
	141157: FLAT FF14P 31CM(DU1)<F"D_F"D> V1.0.0	999-99-00536
	143081: MULTI CABLE (P4T&PRO) CVILUX CP- 01104010 CVILUX CP-01104010 45CM 4X18AWG-90 V1.0.2	900-99-00222
	143124: CABLE TRIO SWITCH UNIT WEIPU M-SP1312- 52CM	940-99-00153
	143125: CABLE ROTEM TRIO L=1M WEIPU M-SP1310- 100CM	940-99-00154

10 Appendix C: Trio Cell Modem Installation

This document details how to install and configure a cell modem in a Trio unit lacking this device.

- Prerequisites
- Installation

10.1 Prerequisites

- Supported Devices
- Required Software
- Internet Access

10.1.1 SUPPORTED DEVICES

Trio Display Card Version 1.1.0 or above supports the modem.

- Order: 940-99-00049 Trio GLOBAL LTE CELL MODEM & EXTERNAL ANTENNA.
- For Trio Display Board versions 1.0 or lower, contact Customer Success.



Figure 82: SIM 940-99-00049 Front and Back

10.1.2 REQUIRED SOFTWARE

Trio cell modem requires the following software installations:

- Image Version 1.5. Consult with a Munters technician on how to install the image.
- Software Version 5.0 or higher. Upgrade this software via the Trio Software Upgrade screen.

10.1.3 INTERNET ACCESS

Trio has a priority system for internet access:

1. LAN connection
2. WIFI
3. Cell modem

If a LAN connection is available, Trio automatically connects to the web via the LAN only, even if the unit supports WIFI or a cell modem connection. If there is no LAN, Trio uses WIFI. Trio will only use the cell modem when the first two options are not available.

10.2 Installation

- Physical Installation
- Configuration

10.2.1 PHYSICAL INSTALLATION

- Modem and SIM Card
- Drilling

10.2.1.1 Modem and SIM Card

1. Locate the designated spot for the modem.
2. Insert the modem into the connector and secure it using the two screws supplied.

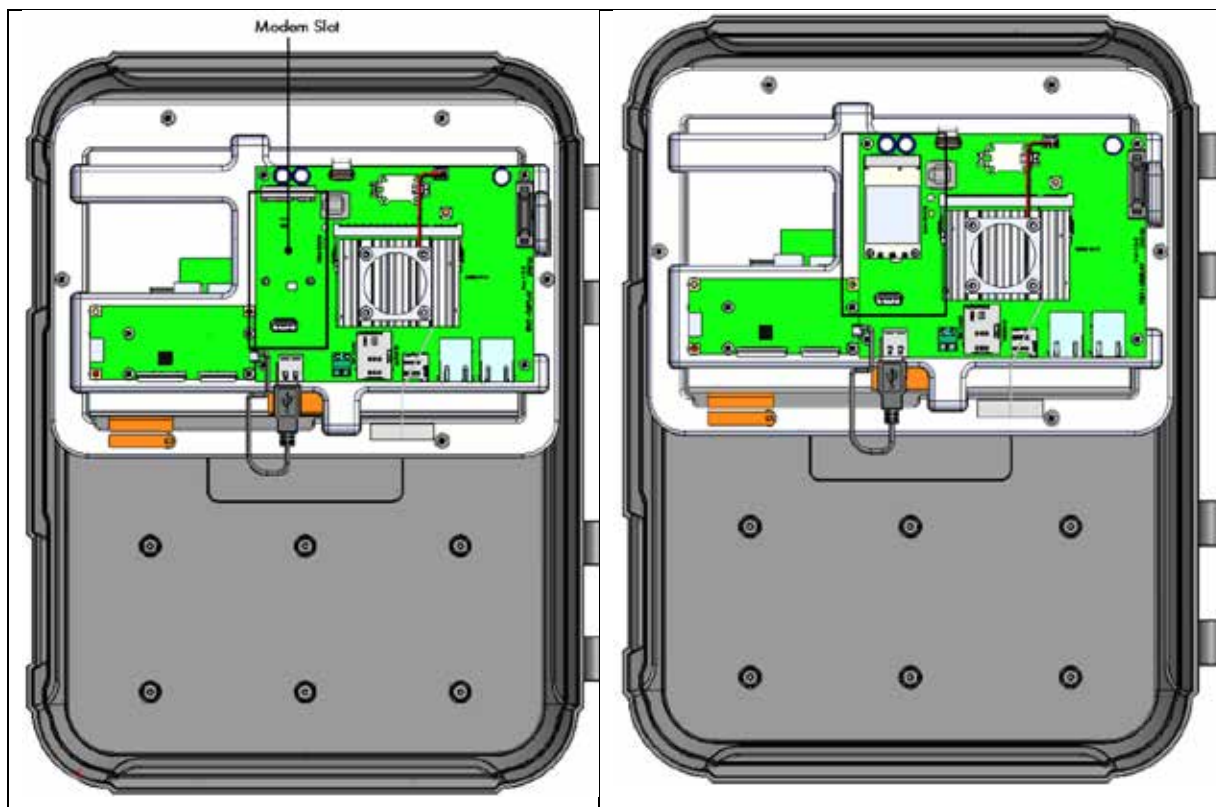

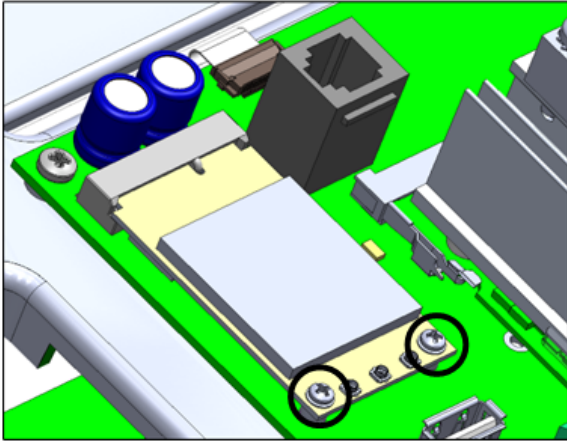

3. Insert the SIM card into the SIM port.

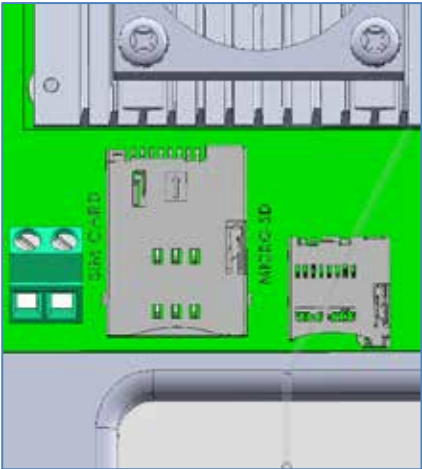

4. Gently press the cable connector onto the modem.

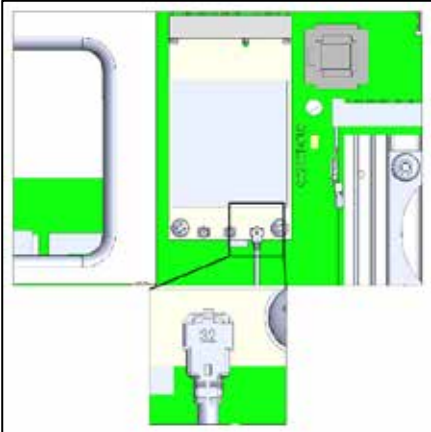

5. Thread the modem cable to the connector as shown below.

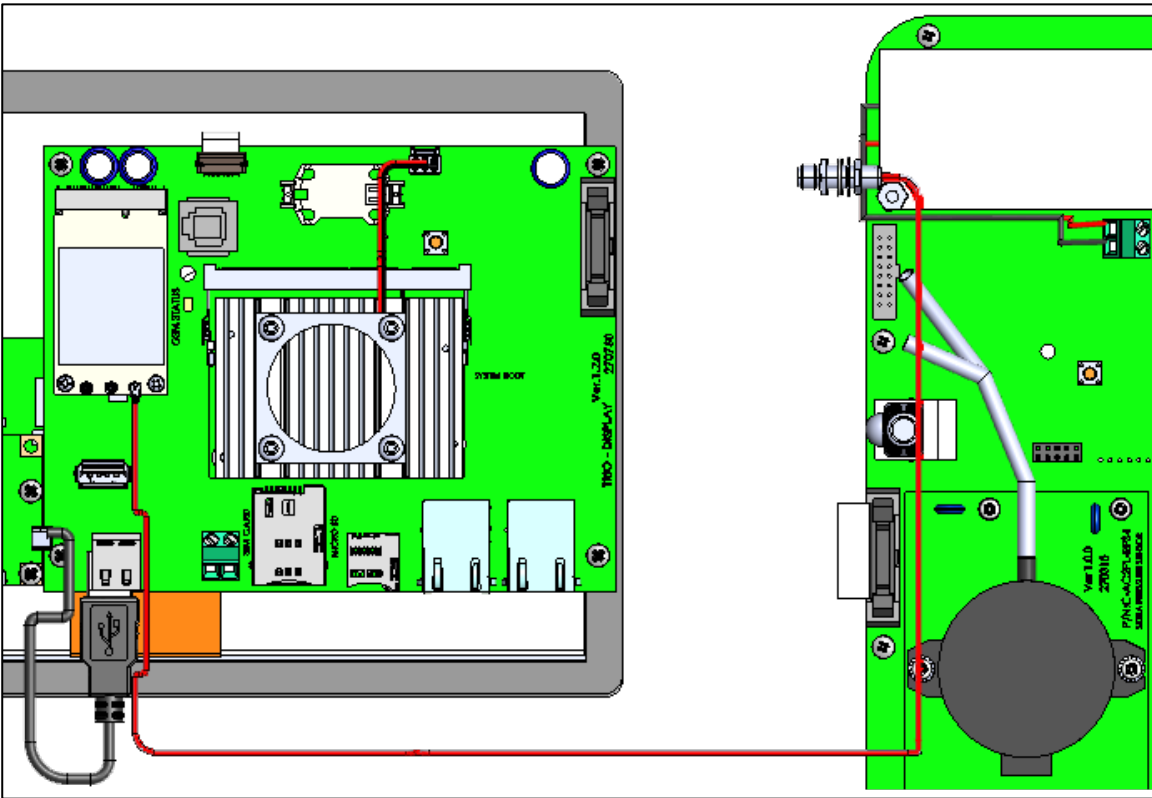
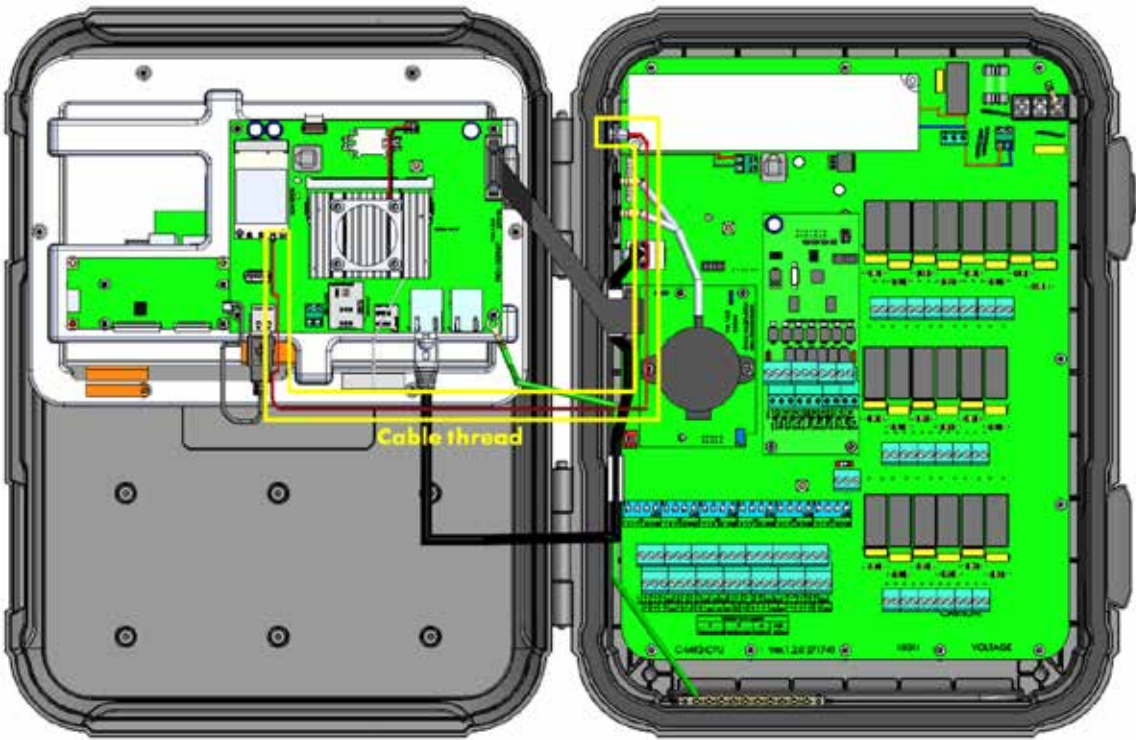

6. Remove the plug in the spot designated for the SMA connector.

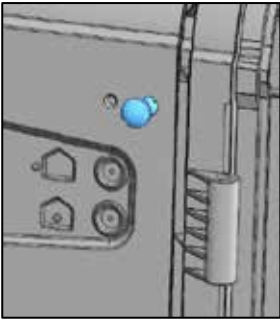

7. Remove the sealing cap and attach the antenna. (For older units, refer to the next section.)

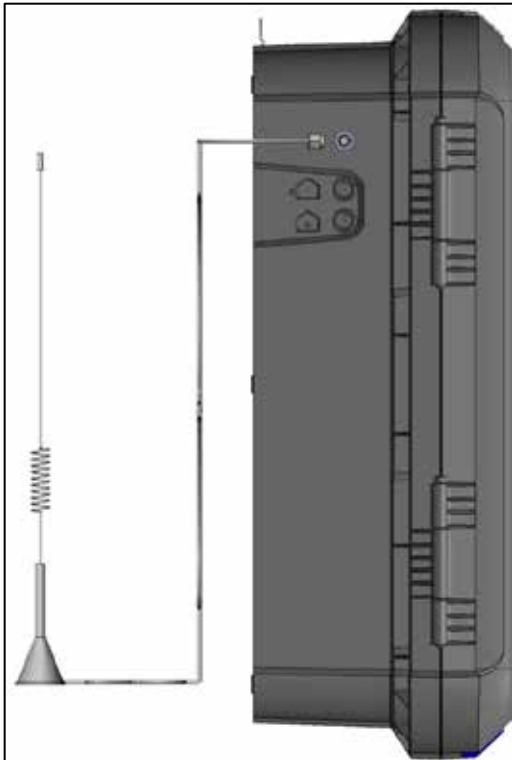

8. Secure the antenna using the brace provided.

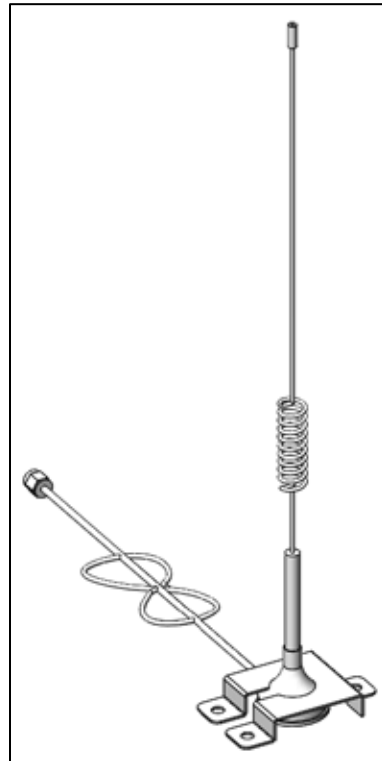

10.2.1.2 Drilling

In the event that the Trio unit was shipped before 08/2022, a hole must be drilled for the SMA connector.

- 1. Drill a 6.5-millimeter hole in the spot shown below.

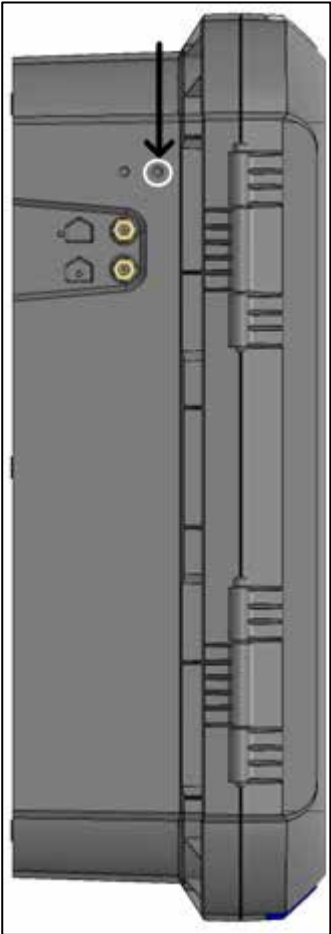

- 2. Insert and secure the SMA connector.

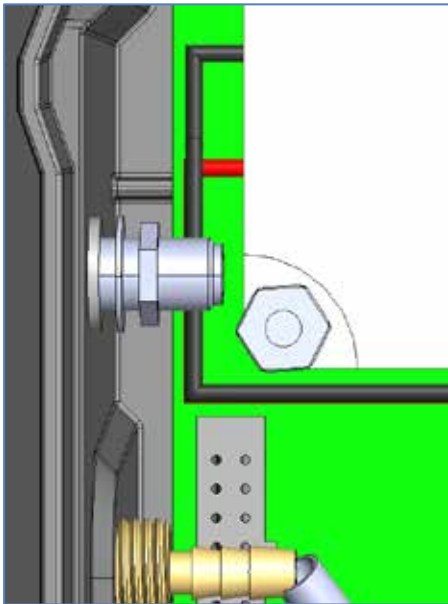
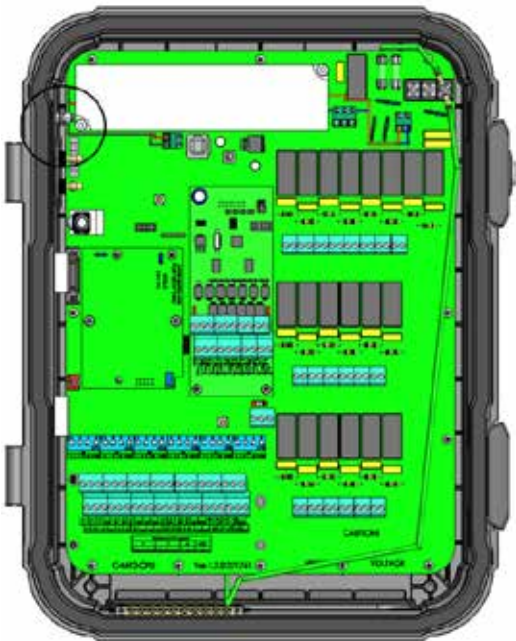

3. Thread the modem cable to the connector as shown below.

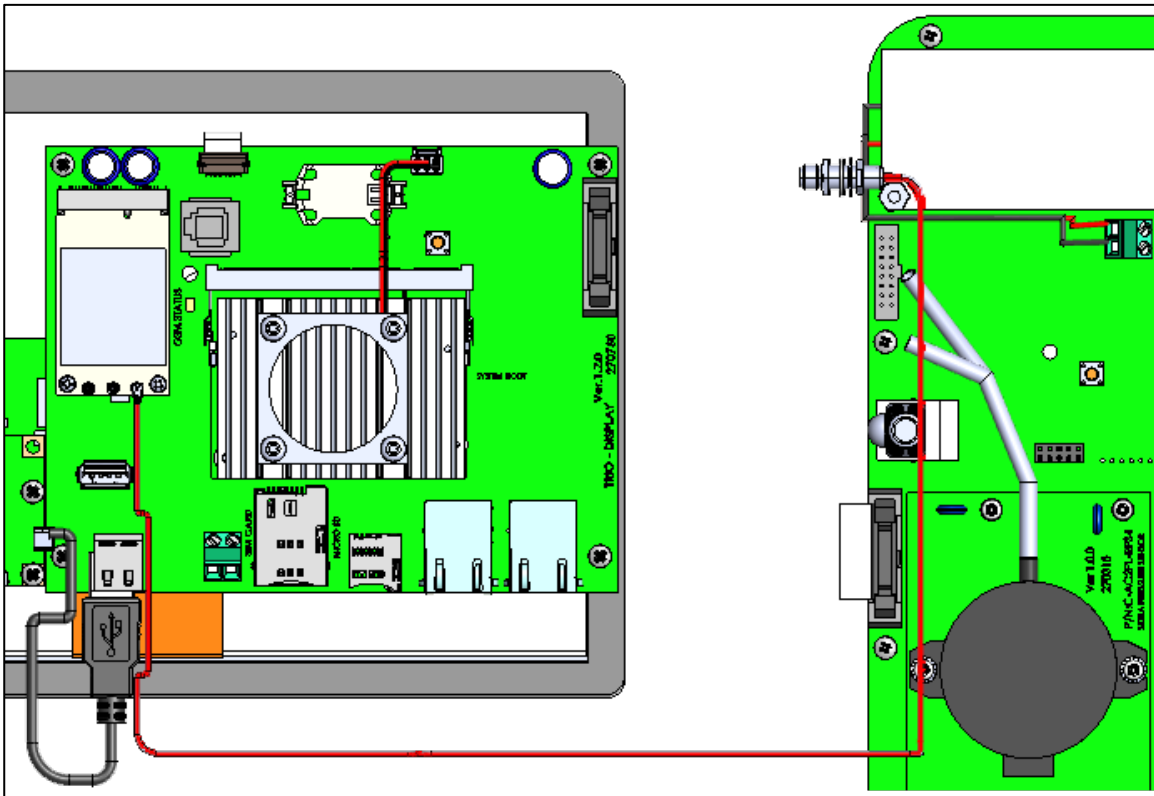
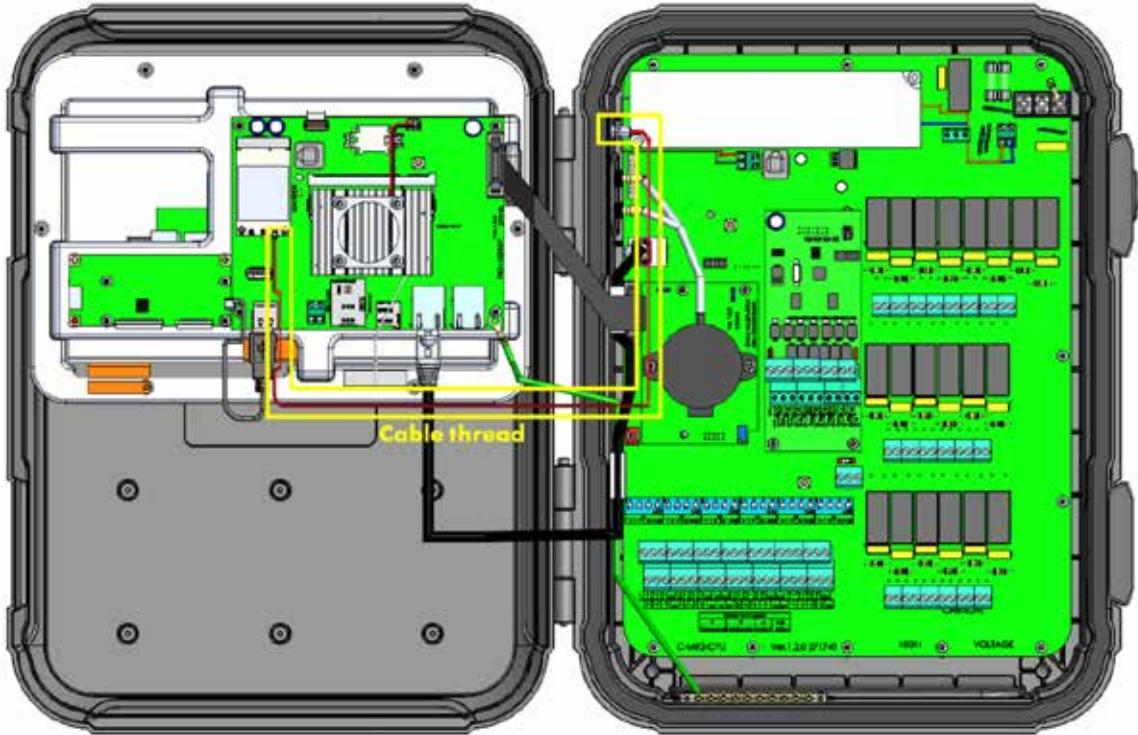

10.2.2 CONFIGURATION

NOTE The cellular Modem function appears only if a modem is installed with a working SIM card.

To configure the cell modem:

1. Go to System > General Settings > Network.

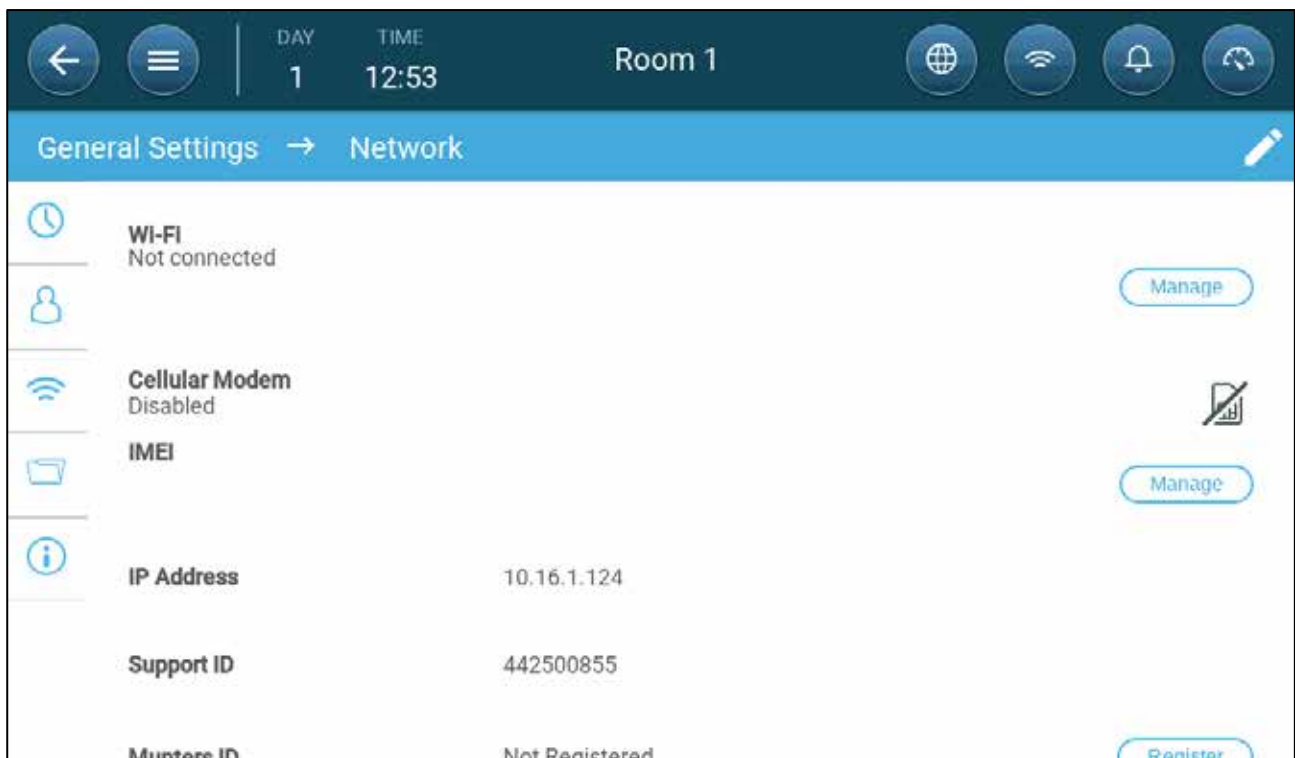

2. Under Cellular Modem, click Manage.

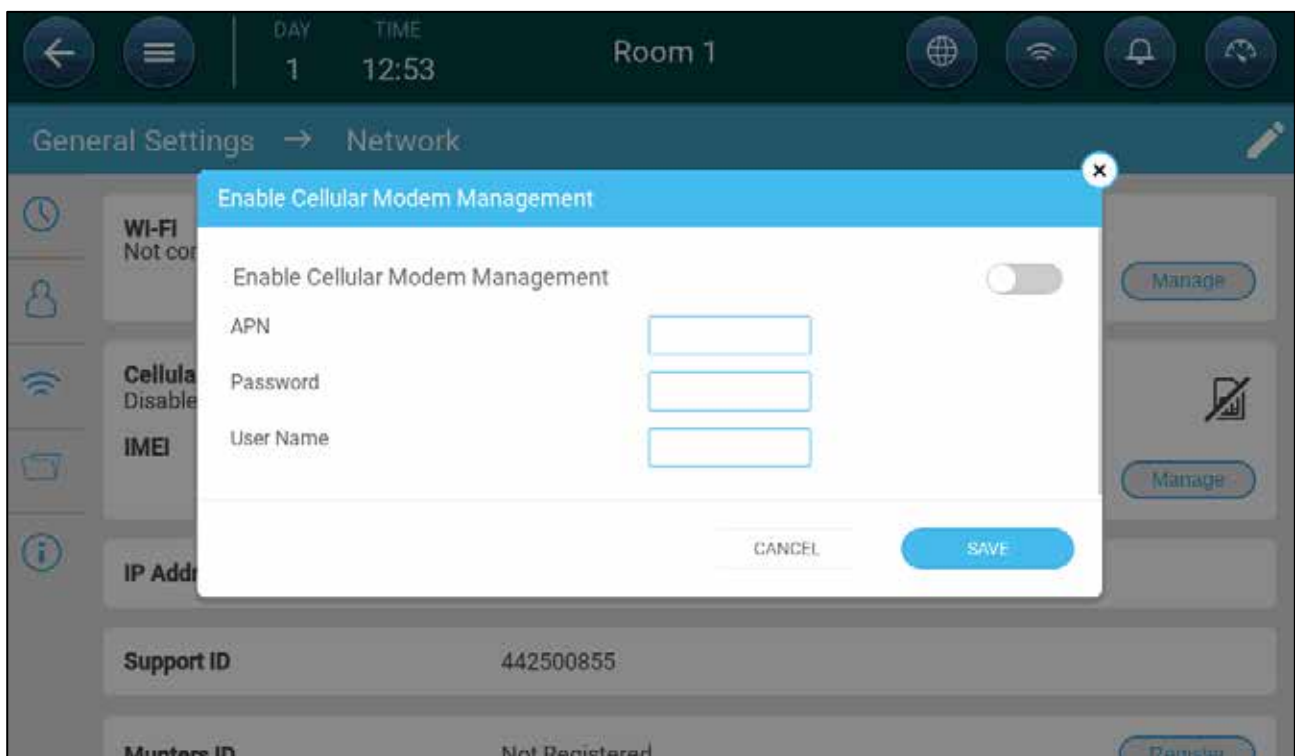

3. Under Cellular Modem, click Manage.

4. Final steps:

- a. Enable the modem.
- b. Using data provided by your service provider, enter the data in the fields.
- c. Click Save.

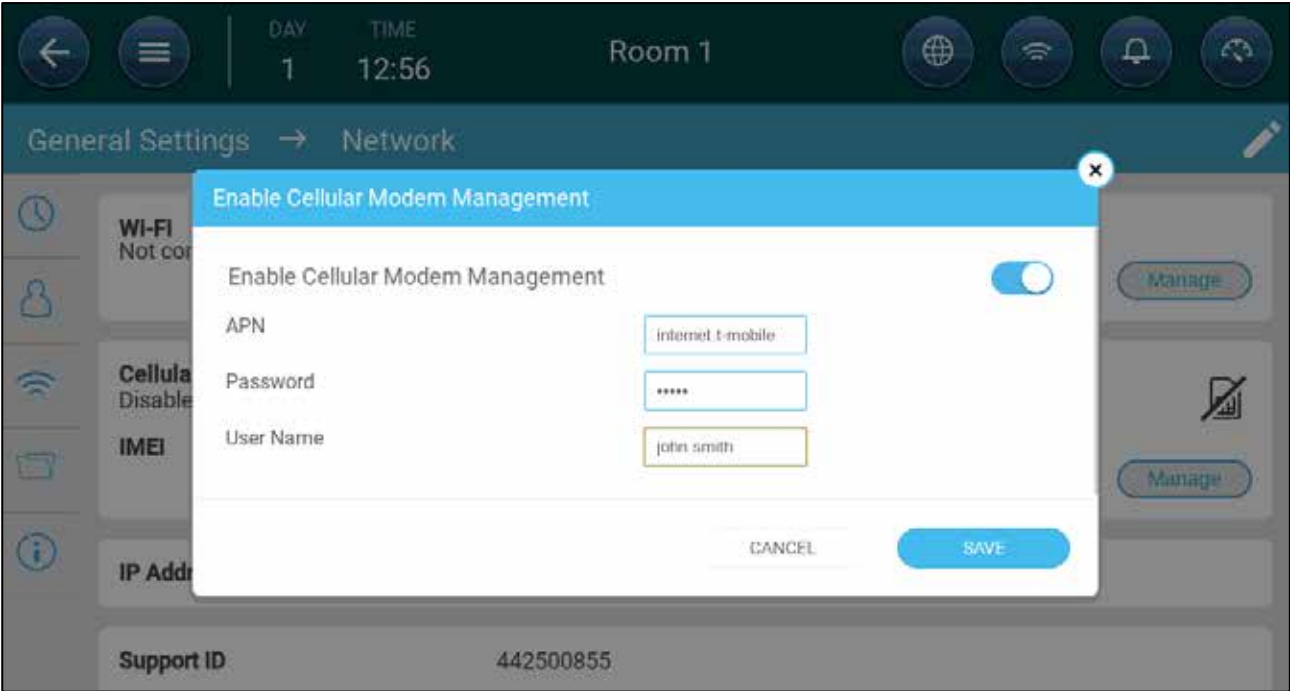

(example only!)

11 Appendix D: IT Setup

The following information is intended for the IT specialist/ISP personnel setting up the internet LAN network between the Communicator 2.0 and Trio Controllers.

- IT Setup
- Subnet Setup
- LAN Cable Information
- Typical Setups

11.1 IT Setup

- Communicator 2.0 for Trio and Trio controllers must be on same subnet LAN.

WARNING! *In order to ensure continual communication, the Communicator 2.0 and Trio LAN must be an independent dedicated subnet.*

- Employ a standard home router, using the default settings, and all devices on the same router.
- On the local network, Communicator 2.0 and Trio must have same the subnet mask (subnet mask must be **255.255.255.0**).
- Three first sections of the Communicator 2.0 and Trio IP address must have the same numbers (for example **192.168.1.x**).
- Network must be IPv4.

NOTE *Munters recommends have a dedicated subnet for the Communicator 2.0/Trio network.*

- The local network can employ a firewall on condition that the following ports are open:

○ Zero-configuration networking (zeroconf)	○ RabbitMQ
○ MQTT	○ AMQPT
○ 15672	○ 1883
○ 4200	○ UDP port 5353
○ UDP port 1900	○ TCP port 3689
○ 5355	○ 1883 MQTT
- Communicator 2.0 has a built-in firewall; all outgoing ports are closed. Incoming ports 8- and 443 are open.

11.2 Subnet Setup

To create a subnet within an industrial network that uses its own DHCP server with the range 192.168.1.1 - 192.168.1.255 or 192.168.2.1 - 192.168.2.255, you need networking equipment capable of isolating and managing traffic.

- Required Equipment
- Procedure

CAUTION *Only Communicator 2.0 for Trio and Trio Controllers can be part of this subnet.*

11.2.1 REQUIRED EQUIPMENT

- Router or Layer 3 Switch:
 - § Capable of creating and managing subnets
 - § Allows routing between subnets if required
 - § Example: Cisco ISR, Ubiquiti EdgeRouter, or MikroTik
- Managed Switch (Optional):
 - § If you need to segment traffic further with VLANs
 - § Example: Cisco Catalyst, TP-Link JetStream, or similar
- DHCP Server or Router with DHCP Capabilities:
 - § Configure a separate DHCP scope for the new subnet
 - § Many modern routers support multiple DHCP scopes
- Firewall (Optional, for added security): To enforce rules between the industrial network and the new subnet

11.2.2 PROCEDURE

1. Define the Subnet: Choose a new IP range (e.g., 192.168.2.0/24)
2. Set Up the Router:
 - Configure a new interface or sub-interface for the new subnet
 - Assign an IP address (e.g., 192.168.2.1) to this interface
3. Configure DHCP for the New Subnet: On the router or a dedicated DHCP server, set a DHCP scope (e.g., 192.168.2.2 - 192.168.2.254)
4. Isolate Traffic:
 - Ensure the industrial network (192.168.1.0/24) and the new subnet (e.g., 192.168.2.0/24) are isolated
 - Use VLANs or routing rules to control traffic flow
5. Connect Devices: Connect devices in the new subnet to the appropriate port on the router/switch

11.3 LAN Cable Information

- Wire/Optical Ethernet Infrastructure Basics
- Trio Connectivity: 100/1000 GBPS Ethernet Switch

11.3.1 WIRE/OPTICAL ETHERNET INFRASTRUCTURE BASICS

- Wire Ethernet 1000/1000 BaseT Copper
 - Media – CAT5E or CAT6 Cable with maximum segment length of 100 meters
- Optical Ethernet 1000Base-X Optical
 - 1000Base-SX Media: Short Haul multi-mode optic fiber (MMF) with maximum segment length of 220 meters (62.5/125 μ m type) or 550 meters (50/125 μ m type)
 - 1000Base-LX Media: Long Haul single-mode optic fiber (SMF) with maximum segment length of 10000 meters
- Connectivity
 - Connectivity is Point-to-Point using 100/1000 Switches
 - Low latency network. If the DHCP takes too long (over 3 minutes) to assign IP addresses to controls, it may cause lost communication alarms when controls reset.
- Equipment
 - Wire Switch serves for Ethernet switching over wire connectivity
 - § Could be with preinstalled specific Optic Transceiver (short or long haul)
 - § Could be with the SFP port, serving for pluggable SFP Optic Transceiver
 - SFP Transceiver pluggable device serving to transmit data over optic fiber
 - § 1000Base-SX SFP serves for multi-mode optic fiber (MMF) of
 - § 62.5/125 μ m type or 50/125 μ m type
 - § 1000Base-LX SFP serves for single-mode optic fiber (SMF)
 - Media Converters server for converting from optics to wire and vice versa. This is used for segments over 100 meters / 330 feet.

11.3.2 TRIO CONNECTIVITY: 100/1000 GBPS ETHERNET SWITCH

- The switch is wired to the router and modem to access the Internet.
- Switches can be wired to each other by Ethernet cables, each one splitting off to other devices.
- Gigabit switches support 100 and 1,000 Mbps.

11.4 Typical Setups

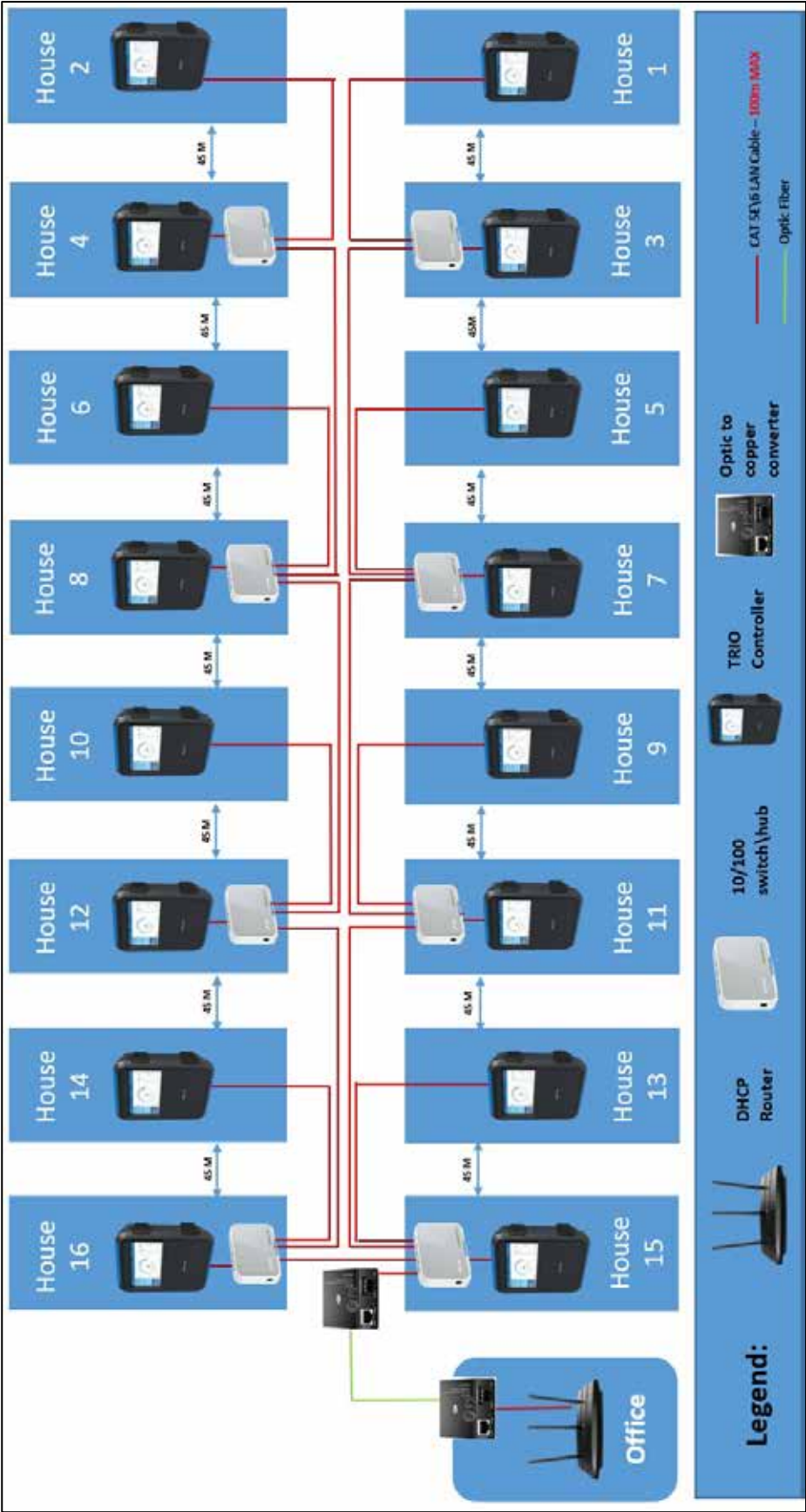

Figure 83: Typical Poultry Installation 1

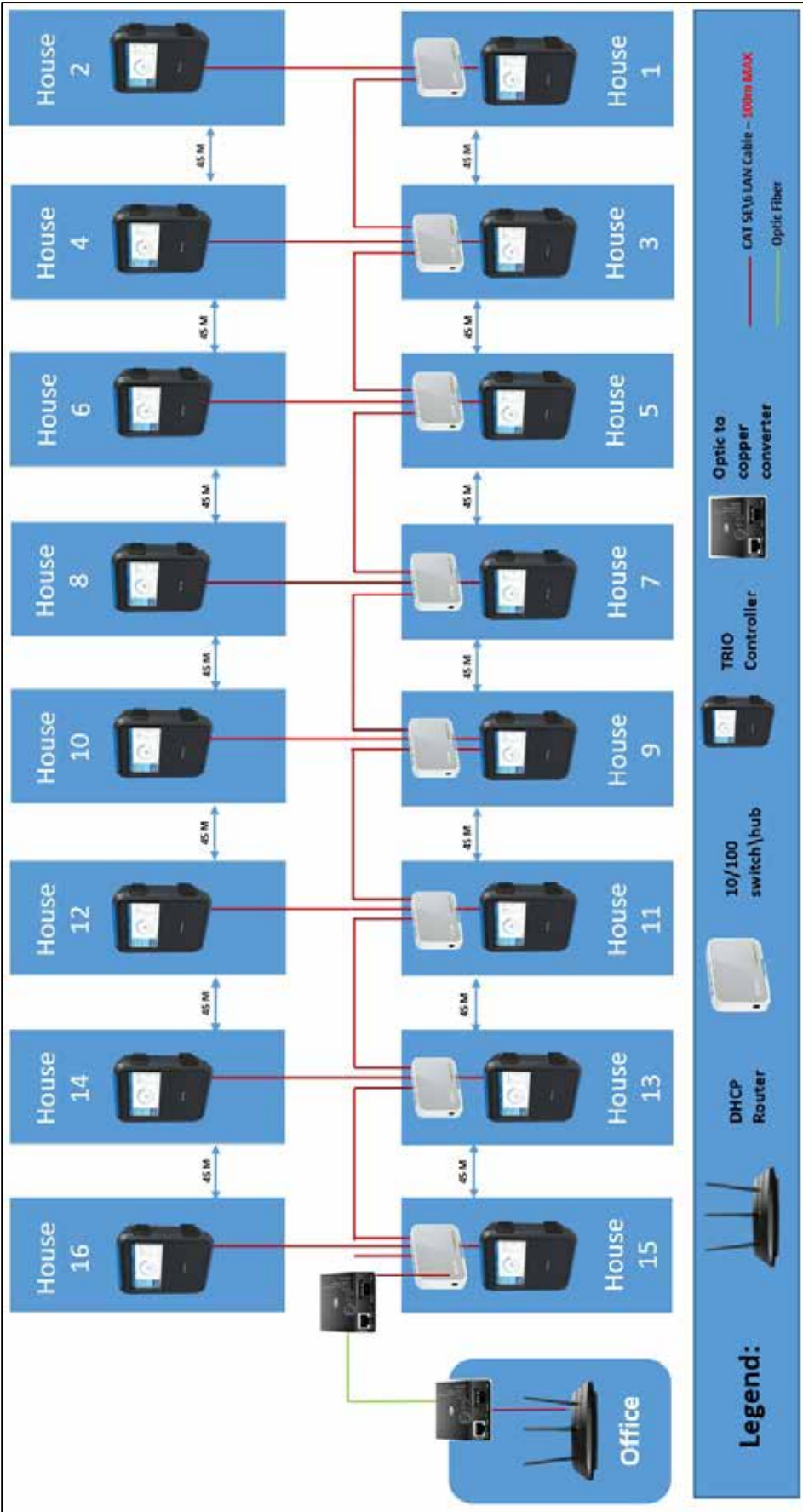

Figure 84: Typical Poultry Installation 2

12 Warranty

Warranty and technical assistance

Munters products are designed and built to provide reliable and satisfactory performance but cannot be guaranteed free of faults; although they are reliable products they can develop unforeseeable defects and the user must take this into account and arrange adequate emergency or alarm systems if failure to operate could cause damage to the articles for which the Munters plant was required: if this is not done, the user is fully responsible for the damage which they could suffer.

Munters extends this limited warranty to the first purchaser and guarantees its products to be free from defects originating in manufacture or materials for one year from the date of delivery, provided that suitable transport, storage, installation and maintenance terms are complied with. The warranty does not apply if the products have been repaired without express authorisation from Munters, or repaired in such a way that, in Munters' judgement, their performance and reliability have been impaired, or incorrectly installed, or subjected to improper use. The user accepts total responsibility for incorrect use of the products.

The warranty on products from outside suppliers fitted to Trio Rotem, (for example antennas, power supplies, cables, etc.) is limited to the conditions stated by the supplier: all claims must be made in writing within eight days of the discovery of the defect and within 12 months of the delivery of the defective product. Munters has thirty days from the date of receipt in which to take action, and has the right to examine the product at the customer's premises or at its own plant (carriage cost to be borne by the customer).

Munters at its sole discretion has the option of replacing or repairing, free of charge, products which it considers defective, and will arrange for their despatch back to the customer carriage paid. In the case of faulty parts of small commercial value which are widely available (such as bolts, etc.) for urgent despatch, where the cost of carriage would exceed the value of the parts, Munters may authorise the customer exclusively to purchase the replacement parts locally; Munters will reimburse the value of the product at its cost price.

Munters will not be liable for costs incurred in demounting the defective part, or the time required to travel to site and the associated travel costs. No agent, employee or dealer is authorised to give any further guarantees or to accept any other liability on Munters' behalf in connection with other Munters products, except in writing with the signature of one of the Company's Managers.

WARNING: In the interests of improving the quality of its products and services, Munters reserves the right at any time and without prior notice to alter the specifications in this manual.

The liability of the manufacturer Munters ceases in the event of:

- dismantling the safety devices;
- use of unauthorised materials;
- inadequate maintenance;
- use of non-original spare parts and accessories.

Barring specific contractual terms, the following are directly at the user's expense:

- preparing installation sites;
- providing an electricity supply (including the protective equipotential bonding (PE) conductor, in accordance with CEI EN 60204-1, paragraph 8.2), for correctly connecting the equipment to the mains electricity supply;
- providing ancillary services appropriate to the requirements of the plant on the basis of the information supplied with regard to installation;
- tools and consumables required for fitting and installation;
- lubricants necessary for commissioning and maintenance.

It is mandatory to purchase and use only original spare parts or those recommended by the manufacturer.

Dismantling and assembly must be performed by qualified technicians and according to the manufacturer's instructions.

The use of non-original spare parts or incorrect assembly exonerates the manufacturer from all liability.

Requests for technical assistance and spare parts can be made directly to the nearest [Munters office](#).

