

# Installation Manual

Trio 20  
Swine  
Controller



# Trio 20

## Swine Controller

Ag/MIS/ImGB-2845-10/22 Rev 4.3  
P/N: 116874



# Trio 20 Swine Controller

## Installation Manual

Rev 4.3, 03/2026

Software Ver: 9.1.10

This manual for use and maintenance is an integral part of the apparatus together with the attached technical documentation.

This document is destined for the user of the apparatus: it may not be reproduced in whole or in part, committed to computer memory as a file or delivered to third parties without the prior authorization of the assembler of the system.

Munters reserves the right to effect modifications to the apparatus in accordance with technical and legal developments.

# Index

<i>Chapter</i>	<i>page</i>
<b>1 INTRODUCTION.....</b>	<b>11</b>
1.1 Disclaimer .....	11
1.2 Introduction .....	11
1.3 Notes .....	11
<b>2 PRECAUTIONS.....</b>	<b>12</b>
2.1 English.....	12
2.1.1 Infrastructure Protection and Backup .....	12
2.1.1.1 RPLP Power Line Protection.....	13
2.1.1.2 RIT-100 Isolated Transformer .....	13
2.1.1.3 TS-02 Timer.....	13
2.1.1.4 Controller Backup .....	14
2.1.2 Protection Against Corrosion.....	14
2.1.3 Electrical Guidelines.....	14
2.1.4 Grounding Sensors.....	14
2.1.5 Reducing Interference .....	14
2.1.6 Filtering.....	15
2.1.7 Checking the CMOS RTC Batteries Level .....	16
2.1.7.1 Display Board Battery .....	16
2.1.7.2 Main Board Battery .....	16
2.1.8 Safety Precautions - Details.....	16
2.1.9 Grounding the Controller.....	17
2.1.9.1 Ground Rods.....	17
2.1.9.2 Ground Wire.....	17
2.1.9.3 Ground Clamps.....	18
2.1.9.4 What Should Be Grounded?.....	18
2.2 Français.....	18
2.2.1 Protection et Redondance de L'infrastructure .....	18
2.2.1.1 Protection de la Ligne D'alimentation RPLP.....	19
2.2.1.2 Transformateur D'isolement RIT-100.....	19
2.2.1.3 Temporisateur TS-02.....	19
2.2.1.4 Contrôleur de Secours .....	20
2.2.2 Protection Contre la Corrosion .....	20
2.2.3 Directives Électriques .....	20
2.2.4 Raccord à la Terre (Sensores).....	21

2.2.5	Réduire les Interférences .....	21
2.2.6	Filtrage.....	21
2.2.7	Vérification du Niveau des piles CMOS RTC .....	22
2.2.7.1	Pile de la Carte D'affichage .....	22
2.2.7.2	Batterie de la Carte Mère.....	22
2.2.8	Précautions de Sécurité - Détails .....	22
2.2.9	Mise à la Terre du Contrôleur .....	23
2.2.9.1	Piquets de Prise de Terre .....	23
2.2.9.2	Fil de Garde.....	23
2.2.9.3	Colliers de Mise à la Terre .....	24
2.2.9.4	Quels Elements Doivent Etre Mis a la Terre?.....	24
2.3	Locking the Trio .....	24
2.4	Product Symbols.....	25
<b>3</b>	<b>UNIT INSTALLATION .....</b>	<b>26</b>
3.1	What Comes in the Package.....	26
3.2	Mounting the Unit.....	26
3.2.1	Knockouts.....	26
3.2.2	Hanging the Unit.....	27
3.3	Board Layout.....	28
3.4	Wiring Diagrams .....	31
3.4.1	High Voltage Relays.....	31
3.4.2	Alarms and Power .....	33
3.4.3	Internet Connection .....	34
3.4.4	Analog Output Devices .....	35
3.4.5	Digital Devices.....	36
3.4.6	Analog Input Devices.....	37
3.4.6.1	CO2 Sensor Wiring.....	37
3.4.6.2	Temperature Sensor Wiring.....	40
3.4.6.3	Humidity Sensor Wiring.....	42
3.4.6.4	Potentiometer Device Wiring .....	44
3.4.6.5	Ammonia Sensor Wiring .....	45
3.4.7	TRIO RPS .....	47
3.4.8	Silo Wiring.....	49
3.4.9	RSU Wiring.....	51
3.5	Termination.....	52
3.6	Pressure Sensor Hoses.....	53
3.7	Tech Support/Wi-Fi .....	53
3.8	SIM Card Configuration .....	54
<b>4</b>	<b>TRIOAIR .....</b>	<b>55</b>
4.1	Access the App.....	55

4.2	Sign Up.....	55
4.3	Adding a Controller to a Farm During Installation .....	56
4.4	Offline Registration .....	58
<b>5</b>	<b>SPECIFICATIONS.....</b>	<b>60</b>
5.1	Trio Specifications.....	60
5.2	Specification Details .....	61
5.3	External Devices Specifications.....	61
<b>6</b>	<b>USING THE TRIO TOUCH SCREEN .....</b>	<b>63</b>
<b>7</b>	<b>MAPPING AND DEFINING THE INPUT OUTPUT DEVICES.....</b>	<b>65</b>
7.1	Using the Mapping Screen .....	65
7.2	Editing the Relays and Sensors.....	68
7.3	Defining Sensors .....	68
7.3.1	Defining Analog Sensor.....	68
7.3.1.1	Enabling/Disabling Analog Input Sensors.....	69
7.3.1.2	Temperature Sensors.....	70
7.3.1.2.1	Defining the Temperature Sensors.....	70
7.3.1.2.2	Mapping the Temperature Sensors.....	70
7.3.1.2.3	Enabling a Weather Station.....	71
7.3.1.3	Defining the Ammonia Sensor .....	72
7.3.1.4	Defining the CO2 Sensor .....	72
7.3.1.5	Defining the Humidity Sensor.....	73
7.3.2	Defining Digital Sensors .....	73
7.3.2.1	Defining the Water Meter Sensors.....	74
7.3.2.2	Defining the Gas Meter Sensors.....	74
7.3.2.3	Defining the Power Meter Sensors.....	75
7.3.2.4	Defining the Feeder Active Sensor .....	75
7.3.2.5	Defining the Feeder Line Sensor .....	76
7.3.2.6	Defining the Auxiliary Input .....	76
7.3.2.7	Defining the Measuring Fan.....	77
7.4	Defining Devices.....	77
7.4.1	0 – 10 Volt Analog Output Devices.....	78
7.4.2	Defining the Fans.....	78
7.4.2.1	On-Off Fans.....	78
7.4.2.2	0 – 10 Volt Fans .....	79
7.4.3	Defining the Stir Fan .....	79
7.4.3.1	On Off Stir Fan.....	79
7.4.3.2	0 – 10 Volt Stir Fan .....	80
7.4.4	Defining the Blowback Fan.....	80
7.4.5	Defining Heating Devices.....	81
7.4.5.1	Defining the On/Off Heaters.....	81

7.4.5.2	Defining the Variable Heaters.....	81
7.4.5.3	Defining the High Heaters .....	82
7.4.6	Defining the Cooling Devices .....	82
7.4.7	Defining the Foggers .....	83
7.4.8	Mapping the Potentiometers, Inlets, Tunnel Doors, Outlets.....	84
7.4.8.1	Mapping the Potentiometers.....	84
7.4.8.2	Defining the Inlets/Tunnel Doors.....	85
7.4.8.2.1	Potentiometer Calibration .....	85
7.4.8.2.2	Calibrating the Inlets/Tunnel Door .....	86
7.4.8.3	Defining the Outlet.....	87
7.4.9	Defining the Sprinkler .....	88
7.4.10	Defining the Same As Relays .....	88
7.4.11	Defining the Same As Analog Ports .....	89
7.4.12	Defining the Timers .....	90
7.4.13	Defining the Feeder Relay.....	90
7.4.14	Defining Fail Safe Devices.....	91
7.5	Mapping the Weighing Devices .....	92
7.5.1	Defining the Silos.....	92
7.5.1.1	Mapping the Silo Scales .....	92
7.5.1.2	Configuring the Silo Scale.....	93
7.5.1.3	Testing the Silo.....	97
7.5.2	Defining the RSU.....	98
7.6	Trio RPS.....	99
7.6.1	Defining the Sensor.....	99
7.6.2	Static Pressure Calibration .....	99
7.7	Testing Devices.....	101
<b>8</b>	<b>APPENDIX A: ALARM BACKUP BATTERY .....</b>	<b>104</b>
8.1	General Description.....	104
8.2	Detailed Description.....	106
8.3	Preparing the Battery for Operation After Transportation or Storage.....	108
<b>9</b>	<b>APPENDIX B: EXTERNAL DEVICE (PREVIOUS VERSIONS) .....</b>	<b>109</b>
<b>10</b>	<b>APPENDIX C: SERVICE MANUAL .....</b>	<b>113</b>
10.1	Maintenance.....	113
10.2	Trouble Shooting .....	114
10.2.1	Internet .....	114
10.2.2	Electronic Components .....	115
10.3	Spare Parts .....	116
10.3.1	Preliminary Information .....	116
10.3.2	Trio Minimal Spare Parts .....	117
10.3.2.1	Global Customers .....	117

10.3.2.2	Chinese Customers .....	117
10.3.3	Trio 20 Container Spare Parts .....	118
10.3.4	Trio 20 Door Card Spare Parts .....	120
10.3.5	Trio 20 Main Container Spare Parts .....	122
10.3.6	Additional Options .....	123
10.3.7	Cards .....	123
10.3.7.1	Door Cards .....	124
10.3.7.2	Main Container Cards .....	125
<b>11</b>	<b>APPENDIX D: TRIO EXPANSION .....</b>	<b>127</b>
11.1	Introduction .....	127
11.2	Expansion 10 .....	127
11.2.1	Expansion Layout.....	128
11.2.2	TRIO to TRIO 10 Expansion Wiring.....	128
11.2.2.1	Wiring.....	129
11.2.2.2	Address .....	130
11.2.2.3	Restart.....	130
11.2.3	High Voltage Relays.....	131
11.2.4	Power .....	132
11.3	Expansion 20.....	133
11.3.1	Expansion Layout.....	133
11.3.2	Expansion Wiring Diagrams .....	134
11.3.2.1	TRIO to TRIO 20 Expansion Wiring .....	134
11.3.2.2	Wiring.....	134
11.3.2.3	Address .....	135
11.3.2.4	Restart.....	135
11.3.3	High Voltage Relays.....	136
11.3.4	Power .....	137
11.4	Mapping Devices in Expansion.....	138
11.5	Expansion Specifications .....	139
11.5.1	Expansion 10 Specifications.....	139
11.5.2	Expansion 20 Specifications .....	140
11.5.3	Expansion Specification Details .....	140
11.6	Expansion Spare Parts .....	141
11.6.1	Preliminary Information .....	141
11.6.2	Trio Expansion 10 Spare Parts.....	141
11.6.2.1	Trio Expansion 10 Container Spare Parts .....	142
11.6.2.2	Trio Expansion 10 Main Container Spare Parts .....	144
11.6.3	Trio Expansion 20 Spare Parts .....	144
11.6.3.1	Trio Expansion 20 Container Spare Parts.....	145
11.6.3.2	Trio Expansion 20 Main Container Spare Parts .....	147
11.6.4	Additional Options .....	148

- 11.6.5 Cards ..... 148
- 12 APPENDIX E: IT SETUP ..... 149**
- 12.1 IT Setup ..... 149
- 12.2 Subnet Setup ..... 150
  - 12.2.1 Required Equipment ..... 150
  - 12.2.2 Procedure ..... 150
- 12.3 LAN Cable Information ..... 151
  - 12.3.1 Wire/Optical Ethernet Infrastructure Basics ..... 151
  - 12.3.2 Trio Connectivity: 100/1000 GBPS Ethernet Switch ..... 151
- 12.4 Typical Setup ..... 152
- 13 INDEX ..... 153**
- 14 WARRANTY ..... 155**

# 1 Introduction

## 1.1 Disclaimer

Munters reserves the right to make alterations to specifications, quantities, dimensions etc. for production or other reasons, subsequent to publication. The information contained herein has been prepared by qualified experts within Munters. While we believe the information is accurate and complete, we make no warranty or representation for any particular purposes. The information is offered in good faith and with the understanding that any use of the units or accessories in breach of the directions and warnings in this document is at the sole discretion and risk of the user.

## 1.2 Introduction

Congratulations on your excellent choice of purchasing a TRIO Swine Controller!

In order to realize the full benefit from this product it is important that it is installed, commissioned and operated correctly. Before installation or using the controller, this manual should be studied carefully. It is also recommended that it is kept safely for future reference. The manual is intended as a reference for installation, commissioning and day-to-day operation of the Munters Controllers.

## 1.3 Notes

Date of release: Jan 2020

Munters cannot guarantee to inform users about the changes or to distribute new manuals to them.

All rights reserved. No part of this manual may be reproduced in any manner whatsoever without the expressed written permission of Munters. The contents of this manual are subject to change without notice.

# 2 Precautions

- English
- Français
- Locking the Trio
- Product Symbols

## 2.1 English

**CAUTION** *Protection provided by the equipment can be impaired if the equipment is used in a manner not specified by the manufacturer!*

**CAUTION** *There is a risk of explosion if the controller's lithium battery is replaced with an incorrect type. Replace the battery using the same type and manufacturer only.*

- Infrastructure Protection and Backup
- Protection Against Corrosion
- Electrical Guidelines
- Grounding Sensors
- Reducing Interference
- Filtering
- Checking the CMOS RTC Batteries Level
- Safety Precautions - Details
- Grounding the Controller

### 2.1.1 INFRASTRUCTURE PROTECTION AND BACKUP

Electrical grid disturbances—including voltage spikes, transient power drops, line fluctuations, and instability—may result in physical damage to controllers if not adequately mitigated.

To prevent controller damage, in areas having known, repeated issues with electrical supply stability Munters requires installing a protection infrastructure consisting of the Munters RPLP, Munters RIT-100, and a Trumeter TS-02 timer. Installing these products are best industrial practice.

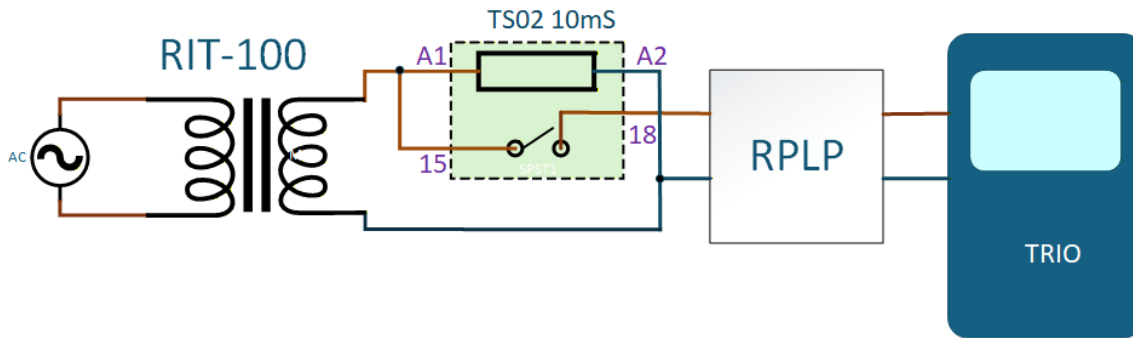

Figure 1: Electrical Protection Setup

- RPLP Power Line Protection
- RIT-100 Isolated Transformer
- TS-02 Timer
- Controller Backup

### 2.1.1.1 RPLP Power Line Protection

Install an RPLP-1 to provide lightning protection to the controllers as well as reducing noise. While no lightning protection is perfect, the RPLP-1 significantly enhances the reliability of built-in lightning protection. Refer to the RPLP-1 documentation for detailed wiring instructions and specifications.

*NOTE Common surge protectors provide little additional protection and may trip unnecessarily.*

- RPLP-1-V2 (230 Volt): P/N: 922-01-00006

### 2.1.1.2 RIT-100 Isolated Transformer

Electronic controllers can be damaged by disturbances in the power supply. Examples of disturbances include:

- Lightning strikes
- Power line spikes

Munters RIT-100 stabilizes incoming power, preventing spikes (very short (microseconds to milliseconds), sharp changes (positive or negative) in voltage). In addition, RIT-100 defends the controller against power surges or lightning strikes that run through a power line. Refer to the RIT-100 documentation for detailed wiring instructions and specifications.

- P/N: 922-02-00006 (RIT100-POU-230V-TO-230V-100VA or 115V-TO-115V-50VA)

### 2.1.1.3 TS-02 Timer

The Trumeter TS-02 timer blocks electrical input when the voltage drops below 120 VAC. After a delay of 10 seconds, the TS-02 reconnects the electrical system once the voltage rises above 150 VAC.

- P/N: TS02 – 240V AC / 24V AC/DC, ON-Delay, 1 C/O

### 2.1.1.4 Controller Backup

Munters strongly recommends that all controllers have a backup controller that operates during a primary controller failure or during extreme temperatures. The backup ensures animal survival in cases of extreme temperatures or power disruptions. The backup controller comes into play when:

- A general controller failure occurs, in this case the controller functions at the current operating temperature.
- House temperatures readings are higher than what is set for the thermostat.

In both situations, the backup controller sends out alarms and/or takes over basic operations.

Munters provides two different backup systems:

- USA/Canada: [RBU-27](#) and [RDT-5](#) (Double Phase)
- EMEA/Asia: [RBU-5](#) (Triple Phase)

### 2.1.2 PROTECTION AGAINST CORROSION

To prevent against corrosion of electrical components:

- Installation location: If possible, install the Trio in a well-ventilated area.
- Keep the Trio closed at all times when a litter or passel is present in the building. In situations where maintenance or repairs are required, close the controller when you finish the work.
- After running the cables through the knockouts, seal the holes with a silicon sealant. If you use silicon sealant with acetic acid cure, keep the controller open and ventilated until cured. Otherwise, the acetic acid will attack metal components, including circuitry.
- When splicing sensors to longer wires, ensure that the splice is **waterproof**. Use adhesive lined heat shrink (marine grade) to make waterproof connections.
- Use shielded wiring for low level signals. For buried wiring (building to building runs) use high grade jell filled cables that are impervious to moisture.

### 2.1.3 ELECTRICAL GUIDELINES

- If this unit is installed in an electrical closet, ensure that no contactors are in that closet. Placing this unit in proximity (50 centimeters/1.5 feet or less) to contactors results in severe signal interference.
- Review the guidelines given in the Precautions and Safety Precautions sections. These are vital to ensuring both personal safety and proper controller functioning.

### 2.1.4 GROUNDING SENSORS

- Every low power device (digital, analog, or communication) must have a shield cable connected to the unit ground strip.

### 2.1.5 REDUCING INTERFERENCE

- Avoid mixing high voltage wiring with sensor and low voltage wiring. There should be at least 3 feet/1 meter between sensor and electrical cables.

- Keep the controller as far as possible from heavy contactor boxes and other sources of electrical interference.
- Do not connect communication wire shields, which go from one house to another at both ends. Connect them at one end only. Connection at both ends can cause ground loop currents to flow, which reduce reliability.
- The communication COM wiring is not the shield wire! The COM, RX and TX wires must connect to each other at all controllers.
- Refer to Safety Precautions - Details, page 16 for more information.

## 2.1.6 FILTERING

If this installation includes a power inverter to drive variable speed fans, RLD, RVS-2, or any device that switches high electrical current, install an EMI filter in front of the device. Refer to the inverter documentation.

Frequency inverters can cause severe electrical and electromagnetic interference. Therefore, when employing a frequency inverter, it is critical that you carefully follow the manufacturer's installation instructions.

In particular verify:

- That the cable shielding between the inverter and any motor meets industry standards
- Proper grounding of the inverter's chassis and motor power cable
- Proper grounding of low voltage cable shield wire
- That the controller and inverter cables are kept in separate conduits or wire bundles

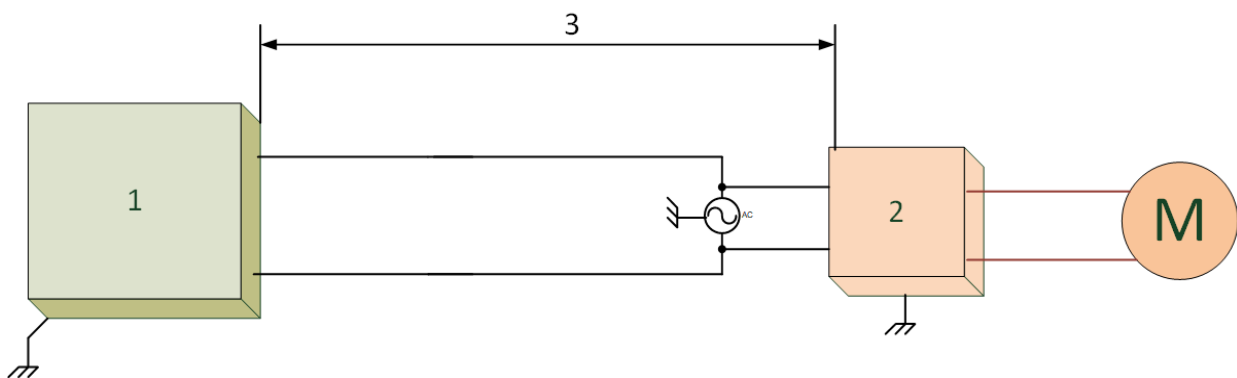

Figure 2: Inverter setup

1. Controller
2. Inverter
3. Place the controller at least 1.5 feet/50 centimeters from the inverter.

## 2.1.7 CHECKING THE CMOS RTC BATTERIES LEVEL

- Display Board Battery
- Main Board Battery

### 2.1.7.1 Display Board Battery

On the Trio Controller Display Board (refer to Figure 11) is a CMOS Battery. This CMOS battery keeps the CPU's real-time clock running when the power is off.

Check the battery once a year. The output must be 2.7 volts (minimum). Authorized personnel only must replace the battery if the output is below the minimum required level or every five years. Use a RENATA-CR2450N battery only.

If the CMOS battery output is below the required minimum, an icon  appears on the touch screen and on the TrioAir app.

**CAUTION** *If the CMOS battery output is below the required minimum, in the event of a power failure the user will have to reset the time and date when power is reapplied.*

### 2.1.7.2 Main Board Battery

On the Trio Controller Main Board is a CMOS Battery. This battery is located behind the Scale Card (refer to Figure 9). This CMOS battery keeps the board's real-time clock running when the power is off.

Do not test this battery. If the CMOS battery output is below the required minimum, Trio sends an alarm to everyone on the contact list. In this event, an authorized technician must replace the battery with a RENATA-CR2450N battery only.

**CAUTION** *If the CMOS battery output is below the required minimum, in the event of a power failure the user will have to reset the time and date when power is reapplied.*

**Warning:** *It is very important to reset the growth date to the required day.*

## 2.1.8 SAFETY PRECAUTIONS - DETAILS

**CAUTION** *An authorized electrician must install these units. Disconnect the power to avoid electrical shock and damage.*

**NOTE** *Installation Category (Over voltage Category) II*

- The power supply to the controller should be protected by a 10 amp circuit breaker.
- All electrical connections should comply with National Electrical code (NEC).

## 2.1.9 GROUNDING THE CONTROLLER

- Ground Rods
- Ground Wire
- Ground Clamps
- What Should Be Grounded?

### 2.1.9.1 Ground Rods

Ground rods are used to efficiently connect the system to earth where current may be dissipated in the soil.

1. Material: Ground rods should be copper clad or galvanized steel.
2. Diameter: Minimum 5/8", preferably 3/4". Generally the larger the rod diameter, the lower it's resistance to current flow.
3. Length: Minimum 2.5 meters (8 feet), preferably 3-meter (10-foot). A longer ground rod will reach a soil with higher moisture content. Moist soil carries current much better than drier soil.
4. Single grounding: It is important that there is only one grounding location where a rod or series of rods are connected to each other using a ground wire.
5. Independent ground rods will increase the risk of current, from a lightning strike for example, being dissipated through one rod and reentering the system through an adjacent rod.
6. Location: Close to the main circuit breaker panel and in moist soil. For example in an area that is usually wet from a drip or a low spot where water drains. Make sure the area is well protected from damage by lawnmowers, tractors, etc.'
7. Rod installation: Drive the rod into the earth until about 10 cm (4 inches) is left above grade. If it is impossible to drive the rod to the proper depth, it is acceptable to lay the rod horizontally, 80 cm (2.5 feet) below grade.
8. In case the rod is exposed to damage, for example by lawnmowers or tractors it can be installed in a hole, about 20 cm (8 inches) deep so that the rod is about 10 cm under grade and 10 cm above hole level.

*NOTE The National Electric Code (NEC) mandates two ground rods unless you can show less than 10 ohms resistance with one rod.*

### 2.1.9.2 Ground Wire

The ground wire is a large copper wire that connects the main circuit breaker panel to the ground rod.

1. Material: Ground rods should be copper clad or galvanized steel.
2. Diameter: Typically, 16 mm (6-gauge) copper wire is sufficient. If the wire run is greater than 20 feet, 20 mm (4-gauge) wire should be used.
3. Length: Minimum 2.5 meters (8 feet), preferably 3-meter (10-foot). A longer ground rod will reach a soil with higher moisture content. Moist soil carries current much better than drier soil.
4. The ground wire should be protected from damage by lawnmowers, tractors, etc. It should be buried at a minimum of 15 cm (6 inches) under grade for protection and

enter the house as soon as possible. It is important that the wire not be cut; it should remain continuous.

### 2.1.9.3 Ground Clamps

Ground wires should not be merely wrapped around a ground rod. Ground clamps are used to attach a ground wire to a ground rod. The most common clamp is known as an acorn clamp. Make sure the ground clamps you select are rated for outdoor use. Do not use pipe clamps rated for inside water lines or hose clamps to attach the ground wire.

### 2.1.9.4 What Should Be Grounded?

Any equipment that is or could become energized, even accidentally, should be grounded. Current from lightning, strikes objects in a random fashion. Accounts of lightning strikes reveal scenarios most of us could not predict.

Electric circuits should be wired with a 3-wire conductor consisting of hot, neutral, and grounding wires. The grounding wire should be attached cleanly and securely to devices or systems to be grounded. The other end of the grounding wire should be attached to the ground bus on the main panel.

## 2.2 Français

- Protection et Redondance de L'infrastructure
- Protection Contre la Corrosion
- Directives Électriques
- Raccord à la Terre (Sensores)
- Réduire les Interférences
- Filtrage
- Vérification du Niveau des piles CMOS RTC
- Précautions de Sécurité - Détails
- Mise à la Terre du Contrôleur

**CAUTION** *La protection fournie par l'équipement peut être compromise si l'équipement est utilisé d'une façon non spécifiée par le fabricant !*

**CAUTION** *Risque d'explosion si la batterie au lithium du contrôleur est remplacée par un modèle inapproprié. Remplacez la batterie uniquement par une batterie du même type et du même fabricant.*

### 2.2.1 PROTECTION ET REDONDANCE DE L'INFRASTRUCTURE

Les perturbations du réseau électrique – y compris les surtensions, les chutes transitoires de tension, les fluctuations de ligne et l'instabilité – peuvent provoquer des dommages physiques aux contrôleurs si elles ne sont pas correctement atténuées.

Pour prévenir les dommages aux contrôleurs, dans les zones où la stabilité de l'alimentation électrique est connue pour poser des problèmes récurrents, Munters exige l'installation d'une infrastructure de protection composée du Munters RPLP, du Munters RIT-100 et d'un temporisateur Trumeter TS-02. L'installation de ces produits constitue une bonne pratique industrielle.

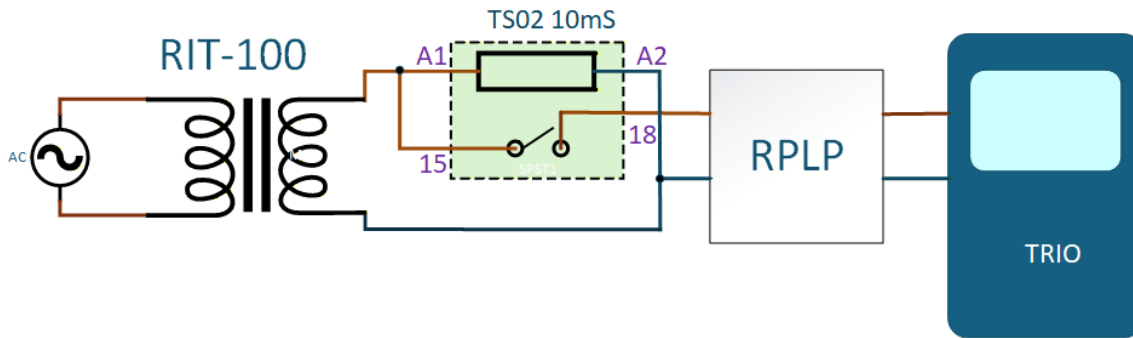

Illustration 3: Configuration de la protection électrique

- Protection de la Ligne D'alimentation RPLP
- Transformateur D'isolement RIT-100
- Temporisateur TS-02
- Contrôleur de Secours

### 2.2.1.1 Protection de la Ligne D'alimentation RPLP

Installez un RPLP-1 pour assurer une protection contre la foudre des contrôleurs ainsi que pour réduire les parasites. Bien qu'aucune protection contre la foudre ne soit parfaite, le RPLP-1 améliore considérablement la fiabilité de la protection intégrée. Reportez-vous à la documentation du RPLP-1 pour les instructions de câblage détaillées et les spécifications.

REMARQUE Les parasurtenseurs courants offrent peu de protection supplémentaire et peuvent se déclencher inutilement.

- RPLP-1-V2 (230 V): P/N: 922-01-00006

### 2.2.1.2 Transformateur D'isolement RIT-100

Les contrôleurs électroniques peuvent être endommagés par des perturbations de l'alimentation électrique. Exemples de perturbations:

- Impacts de foudre
- Pics de tension sur la ligne d'alimentation

Le Munters RIT-100 stabilise l'alimentation entrante, en empêchant les pics (variations très brèves – microsecondes à millisecondes – et abruptes, positives ou négatives, de la tension). En outre, le RIT-100 protège le contrôleur contre les surtensions ou les impacts de foudre se propageant via la ligne d'alimentation. Reportez-vous à la documentation du RIT-100 pour les instructions de câblage détaillées et les spécifications.

- P/N: 922-02-00006 (RIT100-POU-230V-TO-230V-100VA ou 115V-TO-115V-50VA)

### 2.2.1.3 Temporisateur TS-02

Le temporisateur Trumeter TS-02 bloque l'entrée électrique lorsque la tension chute en dessous de 120 VAC. Après un délai de 10 secondes, le TS-02 rétablit l'alimentation une fois la tension remontée au-dessus de 150 VAC.

- P/N: TS02 – 240 V AC / 24 V AC/DC, retard à l'enclenchement (ON-Delay), 1 contact inverseur (1 C/O)

### 2.2.1.4 Contrôleur de Secours

Munters recommande fortement que tous les contrôleurs disposent d'un contrôleur de secours qui prenne le relais en cas de défaillance du contrôleur principal ou de températures extrêmes. Le système de secours garantit la survie des porcs en cas de températures extrêmes ou de perturbations de l'alimentation électrique. Le contrôleur de secours intervient lorsque:

- Une défaillance générale du contrôleur se produit ; dans ce cas, le contrôleur fonctionne à la température de fonctionnement actuelle.
- Les relevés de température du bâtiment sont supérieurs à la consigne du thermostat.

Dans les deux cas, le contrôleur de secours émet des alarmes et/ou prend en charge les opérations de base.

Munters propose deux systèmes de secours différents:

- USA/Canada: [RBU-27](#) et [RDT-5](#)
- EMEA/Asie: [RBU-5](#)

### 2.2.2 PROTECTION CONTRE LA CORROSION

Pour éviter la corrosion des composants électriques:

- Installez les commandes électroniques dans une salle de commande ventilée séparée, à l'abri des températures extrêmes et des environnements sales. Placer les commandes de façon à ce que les opérateurs puissent facilement les utiliser et lire les indicateurs et les affichages.
- Gardez le contrôleur fermé à tout moment lorsqu'il y a de la poubelle ou un passage dans le bâtiment. Dans les situations nécessitant une maintenance ou des réparations, fermez le contrôleur lorsque vous avez terminé le travail.
- Après avoir acheminé les câbles à travers les ouvertures, scellez les trous avec un produit d'étanchéité au silicone. Si vous utilisez un mastic de silicone avec durcissement à l'acide acétique, maintenez le contrôleur ouvert et ventilé jusqu'à ce qu'il durcisse. Sinon, l'acide acétique attaquera les composants métalliques, y compris les circuits.
- Lors du raccordement de capteurs à des câbles plus longs, assurez-vous que le raccordement est étanche. Utilisez une gaine thermorétractable adhésive (qualité marine) pour réaliser des connexions étanches.
- Utilisez un câblage blindé pour les signaux de faible niveau. Pour les câbles enterrés (d'un bâtiment à l'autre), utilisez des câbles remplis de gel de haute qualité, imperméables à l'humidité.

### 2.2.3 DIRECTIVES ÉLECTRIQUES

- Munters recommande vivement que seuls les contrôleurs montés sur panneau soient installés directement dans une armoire électrique.
- Placer cette unité à proximité (50 centimètres/1,5 pieds maximum) de tout appareil électrique transmettant 10 ampères ou plus de courant peut entraîner de graves interférences de signal.

- Consulter les consignes données dans Précautions de Sécurité - Détails, page 22 pour plus de détails. Elles sont essentielles pour garantir à la fois la sécurité personnelle et le bon fonctionnement du contrôleur.

## 2.2.4 RACCORD À LA TERRE (SENSORES)

- Chaque appareil à faible puissance (numérique, analogique ou de communication) doit être équipé d'un câble blindé raccordé à la barrette de mise à la terre de l'unité.

## 2.2.5 RÉDUIRE LES INTERFÉRENCES

- Maintenez les câbles basse tension séparés des câbles haute tension. Il doit y avoir au moins un mètre entre le capteur et les câbles électriques.
- Maintenez le contrôleur aussi loin que possible du boîtier lourd de contacteur et des autres sources d'interférences électriques.
- Ne connectez les protections des fils de communication, allant d'une maison à une autre aux deux extrémités. Connectez-les à une seule extrémité uniquement. La connexion aux deux extrémités peut entraîner la circulation de courants dans la boucle de terre, et risquer ainsi de réduire la fiabilité.
- La connexion COM pour les communications n'est pas le fil blindé. Les fils COM, RX et TX doivent être connectés les uns aux autres au niveau de tous les contrôleurs.

## 2.2.6 FILTRAGE

Si cette installation comprend un onduleur pour entraîner des ventilateurs à vitesse variable, RLD, RVS-2 ou tout autre dispositif qui commute un courant électrique élevé, installez un filtre EMI devant l'appareil. Reportez-vous à la documentation de l'appareil.

- Que le blindage du câble entre l'appareil et tout moteur est conforme aux normes industrielles
- Mise à la terre correcte du châssis de l'appareil et du câble d'alimentation du moteur
- Mise à la terre correcte du fil blindé du câble basse tension
- Que les câbles du contrôleur et de l'appareil sont conservés dans des conduits ou faisceaux de câbles séparés

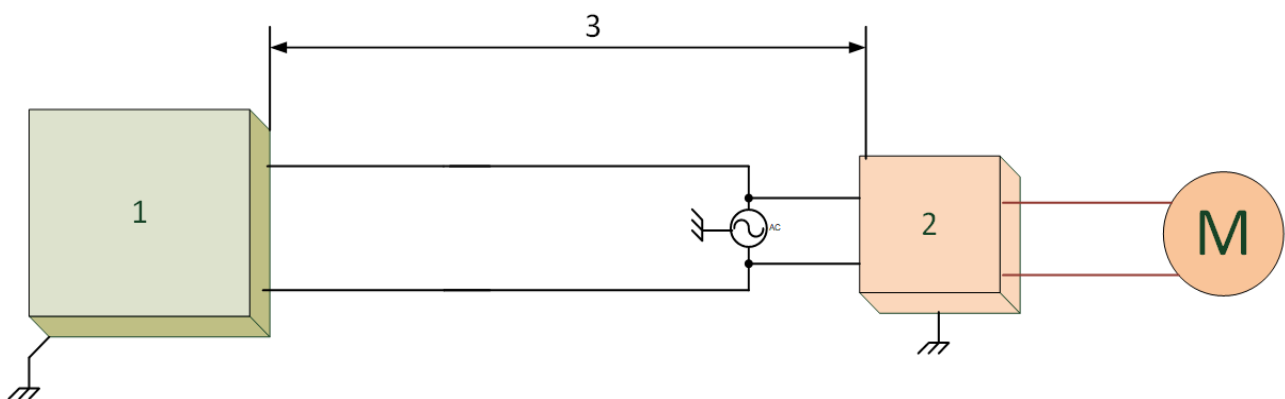

Illustration 4: Emplacement de l'onduleur

1. Contrôleur
2. Dispositif de courant électrique élevé
3. Placez le contrôleur à au moins 50 centimètres de l'appareil

## 2.2.7 VÉRIFICATION DU NIVEAU DES PILES CMOS RTC

- Pile de la Carte D'affichage
- Batterie de la Carte Mère

### 2.2.7.1 Pile de la Carte D'affichage

La carte d'affichage Trio (voir Utilisation de l'écran tactile Trio) est équipée d'une pile CMOS. Cette pile CMOS permet à l'horloge temps réel du processeur de continuer à fonctionner lorsque l'appareil est hors tension.

Vérifiez la batterie une fois par an. La tension doit être de 2,7 volts (minimum). Seul le personnel autorisé doit remplacer la batterie si la tension est inférieure au niveau minimum requis ou tous les cinq ans. Utilisez uniquement une batterie RENATA-CR2450N.

Si la tension de la batterie CMOS est inférieure au minimum requis, une icône  apparaît sur l'écran tactile et dans l'application TrioAir.

**CAUTION** *ATTENTION Si la tension de la batterie CMOS est inférieure au minimum requis, en cas de panne de courant, l'utilisateur devra réinitialiser l'heure et la date lorsque le courant sera rétabli.*

### 2.2.7.2 Batterie de la Carte Mère

La carte mère Trio est équipée d'une batterie CMOS. Cette batterie est située derrière la carte de pesée (voir figure 7). Cette batterie CMOS permet à l'horloge en temps réel de la carte de continuer à fonctionner lorsque l'appareil est hors tension.

Ne testez pas cette batterie. Si la sortie de la batterie CMOS est inférieure au minimum requis, Trio envoie une alarme à toutes les personnes figurant sur la liste de contacts. Dans ce cas, un technicien agréé doit remplacer la batterie par une batterie RENATA-CR2450N uniquement.

**CAUTION** *ATTENTION Si la tension de la batterie CMOS est inférieure au minimum requis, en cas de panne de courant, l'utilisateur devra réinitialiser l'heure et la date lorsque le courant sera rétabli.*

**WARNING!** *Avertissement: il est très important de réinitialiser la date de croissance au jour requis.*

## 2.2.8 PRÉCAUTIONS DE SÉCURITÉ - DÉTAILS

**NOTE** *Catégorie d'installation (catégorie de surtension) II*

- L'alimentation électrique du contrôleur doit être protégée par un disjoncteur de 10 A.
- Tous les raccordements électriques doivent être conformes au National Electrical Code (NEC)

## 2.2.9 MISE À LA TERRE DU CONTRÔLEUR

- Piquets de Prise de Terre
- Fil de Garde
- Colliers de Mise à la Terre
- Quels Elements Doivent Etre Mis a la Terre?

### 2.2.9.1 Piquets de Prise de Terre

Les piquets de prise de terre sont utilisés pour connecter efficacement le système à la terre, lorsque le courant peut être dissipé dans le sol.

1. Matériel: Les piquets de prise de terre doivent être plaqués cuivre ou en acier galvanisé.
2. Diamètre: Minimum 12,5/20,3 cm, de préférence 7,6/10,16 cm. Généralement, plus le diamètre du piquet est gros, moindre sera sa résistance à la circulation du courant.
3. Longueur: Au minimum 2,5 mètres, de préférence 3 mètres. Un piquet de prise de terre plus long atteindra un sol avec une humidité plus élevée. Des sols humides portent beaucoup mieux le courant que des sols plus secs.
4. Mise à la terre unique: Il est essentiel qu'il n'y ait qu'un seul emplacement de mise à la terre auquel un piquet ou une série de piquets sont connectés les uns aux autres à l'aide d'un fil de garde.
5. Des piquets de prise de terre indépendants augmenteraient le risque de courant, provenant par exemple d'un éclair, dissipé par un piquet et réintégrant le système par un piquet adjacent.
6. Emplacement: Prêt du panneau de panneau du disjoncteur principal et dans un sol humide. Par exemple, dans une zone qui est habituellement humide provenant de précipitation, ou un point bas où l'eau est drainée. Assurez-vous que la zone est bien protégée des dommages pouvant être causés par des tondeuses à gazon, des tracteurs, etc.
7. Installation du piquet: Enfoncez le piquet dans le sol jusqu'à ce qu'il reste 10 cm au dessus du niveau du sol. S'il est impossible d'enfoncer le piquet à une profondeur correcte, vous pouvez poser le piquet horizontalement, 80 cm en dessous du niveau du sol.
8. Dans le cas où le piquet risque d'être endommagé, par exemple, par des tondeuses à gazon ou des tracteurs, il peut être installé dans un trou, à une profondeur d'environ 20 cm pour que le piquet soit environ 10 cm en dessous du niveau du sol et 10 cm au dessus du niveau du trou.

*NOTE Le National Electric Code (NEC) a comme impératif l'utilisation de deux piquets de prise de terre, à moins que vous puissiez montrer que la résistance est inférieure à 10 ohms avec un piquet.*

### 2.2.9.2 Fil de Garde

Le fil de garde est un fil cuivré long et épais qui connecte le panneau du disjoncteur principal au piquet de prise de terre.

1. Matériel: Les piquets de prise de terre doivent être plaqués cuivre ou en acier galvanisé.

2. Diamètre: Généralement un fil cuivré de 16 mm (de calibre no. 6) suffit. Si le fil doit parcourir plus de 7m, un fil de 20 mm (de calibre no.4) devrait être utilisé.
3. Longueur: Au minimum 2,5 mètre, de préférence 3 mètres. Un piquet de prise de terre plus long atteindra un sol avec une humidité plus élevée. Des sols humides portent beaucoup mieux le courant que des sols plus secs.
4. Le fil de garde devrait être protégé des dommages pouvant être provoqués par des tondeuses à gazon, des tracteurs, etc. Il devrait être enterré au moins à 15 cm sous le sol pour protection, et être inséré dans la maison aussi vite que possible. Il est important que le fil ne soit pas coupé, il devrait rester entier.

### 2.2.9.3 Colliers de Mise à la Terre

Des fils de gardes ne devraient pas simplement revêtir un piquet de prise de terre. Des colliers de mise à terre sont utilisés pour attacher un fil de garde au piquet de prise de terre. Le collier le plus ordinaire est un collier ocre. Assurez-vous que les colliers de mise à terre que vous sélectionnez sont adaptés à une utilisation à l'extérieur. N'utilisez pas de collier de serrage adapté pour des conduites d'eau intérieures ou colliers de serrage pour tuyaux flexibles pour rattacher le fil de garde.

### 2.2.9.4 Quels Elements Doivent Etre Mis a la Terre?

Tout équipement qui est ou pourrait être sous tension, même accidentellement, devrait être mis à la terre. Les objets qui pourraient être aléatoirement porteurs de la foudre y sont inclus. Des récits de foudre ont montré des cas imprévisibles.

Les circuits électriques devraient être câblés avec un conducteur à 3 fils, constitué d'un fil de garde, d'un fil conducteur neutre et d'un fil chaud. Le fil de garde devrait être rattaché nettement et sûrement aux dispositifs ou aux systèmes à mettre à la terre. L'autre extrémité du fil de garde devrait être rattachée au collecteur de terre sur le panneau principal.

## 2.3 Locking the Trio

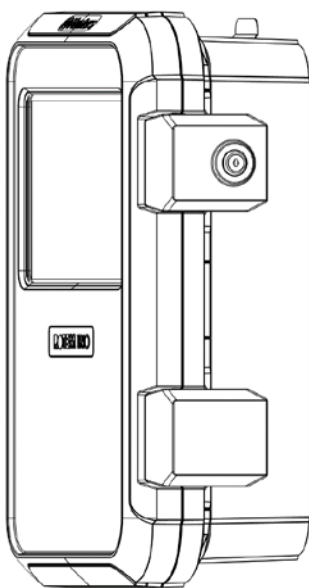

Ensure that the units remains locked to prevent unauthorized access to internal components.

Figure 5: Trio Lock

## 2.4 Product Symbols

The following labels appear on your controller:



: Caution! Hazardous voltage



: Caution: Refer to the manual



: Main Protective Earthing Terminal

**CAUTION** IF THE UNIT IS USED IN A MANNER NOT SPECIFIED BY THE MANUFACTURER, THE PROTECTION PROVIDED BY THE EQUIPMENT MAY BE IMPAIRED.

# 3 Unit Installation

The following sections detail how to mount and wire the TRIO.

*NOTE Munters recommends that a trained technician perform the following operations.*

- What Comes in the Package
- Mounting the Unit
- Board Layout
- Wiring Diagrams
- Termination
- Pressure Sensor Hoses
- Tech Support/Wi-Fi
- SIM Card Configuration

## 3.1 What Comes in the Package

- One Trio unit
- One hanging bracket and screws
- Two keys
- RTS-2 sensors (number depending on order)

## 3.2 Mounting the Unit

- Knockouts
- Hanging the Unit

### 3.2.1 KNOCKOUTS

1. On the bottom the TRIO are knockouts used to route the low and high voltage cables.

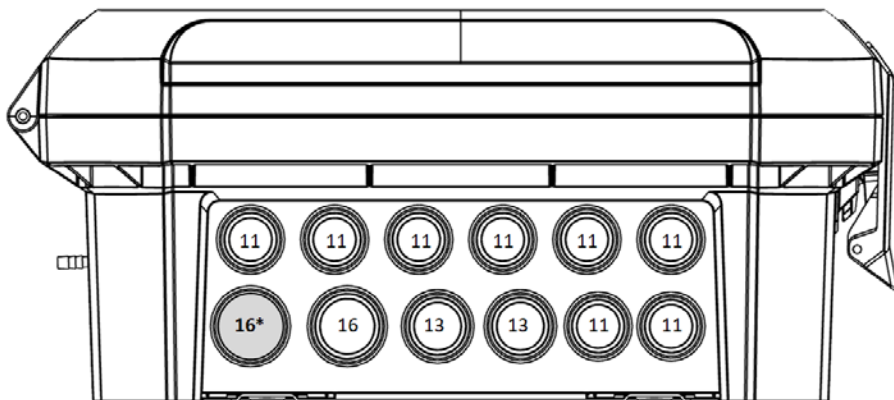

Figure 6: TRIO Knockouts and PG Size

- Using a screwdriver and a hammer, gently apply pressure to the knockouts.
- **Only open the holes that you require.**
- Munters recommends removing the knockouts before mounting the unit.
- 16\*: Use this knockout for the Ethernet cable. .

2. Place the required cables through the cable holders at the bottom of the unit.

**CAUTION** Run low voltage cables through one knockout and high voltage relay cables through a separate knockout. Do not place them in the same knockout!

### 3.2.2 HANGING THE UNIT

1. Using the supplied screws, attach the bracket to the wall.

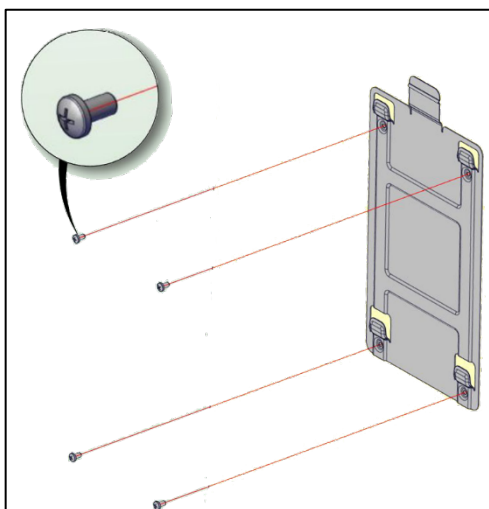

Figure 7: Hang the Bracket

2. Hang the TRIO on the bracket.

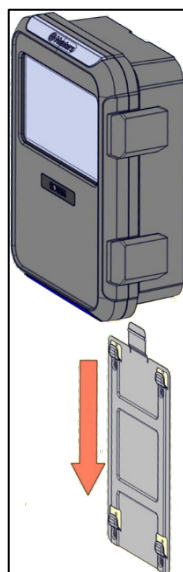

Figure 8: Hanging the Unit

3. Close the TRIO enclosure lid carefully and tightly. Use RTV silicon or equivalent sealant to seal the cable holders.

**CAUTION** Munters strongly recommends that you seal all entry spots with RTV silicon. Failure to do so can lead to damage to the unit.

4. After installation is completed, operate the TRIO for a few hours and re- check for proper operation.

### 3.3 Board Layout

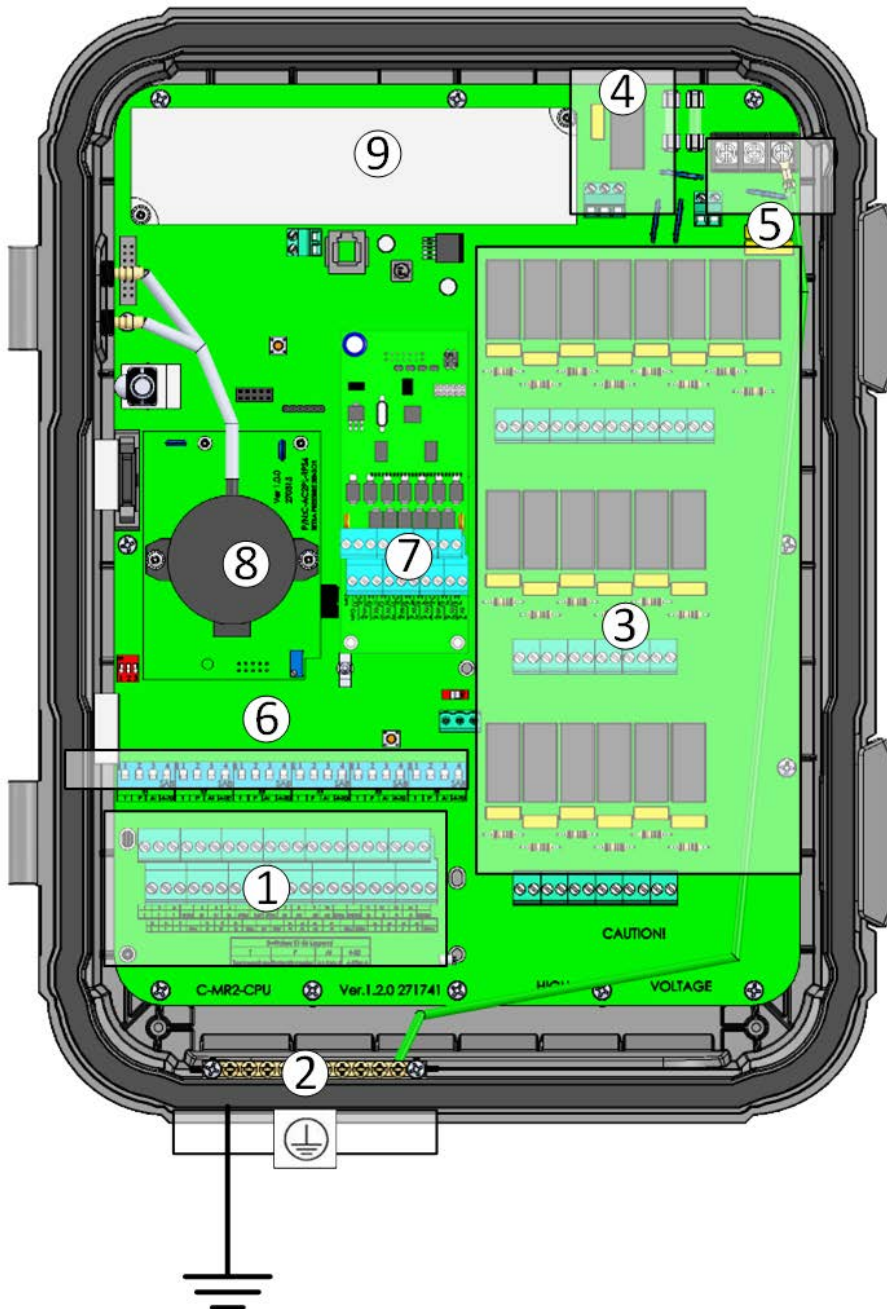

Figure 9: Main Board layout

1	Analog/digital ports	6	Dipswitches
2	Ground strip	7	Scale Card (option) (CMOS battery is under the card)
3	20 relays	8	Pressure Sensor
4	Alarm relay	9	Power Supply
5	Power ports		



Figure 10: Dipswitches, expanded

- One dipswitch only in each set is raised.
- Only raise a dipswitch if a device is wired to an S port.

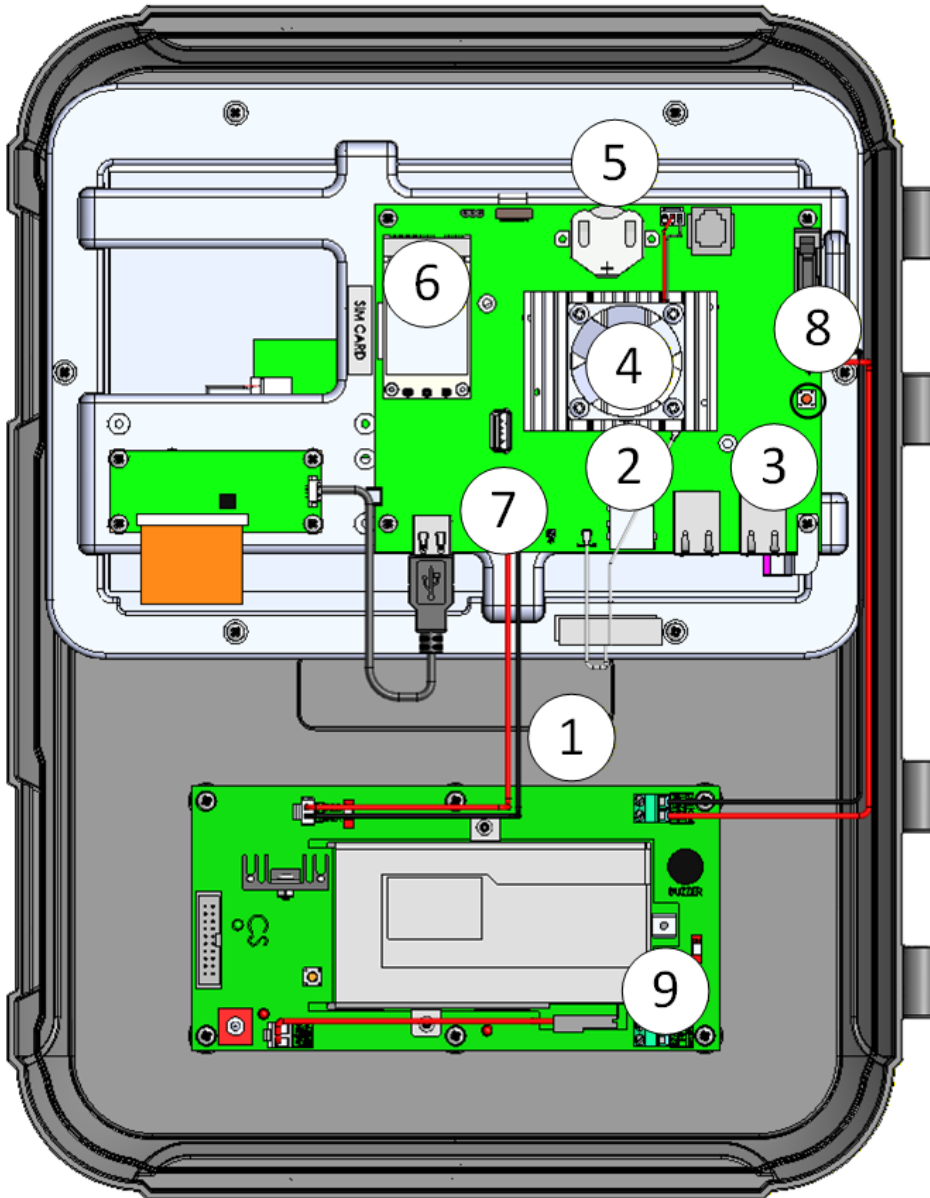

Figure 11: Display Board layout, Display Card Version 1.1.0

1	Wireless antenna
2	SD Port
3	Ethernet Port
4	Heat Sink
5	3V Battery
6	Modem
7	USB Port
8	Reset Button
9	Backup Battery (refer to Appendix A: Alarm Backup Battery, page 104)

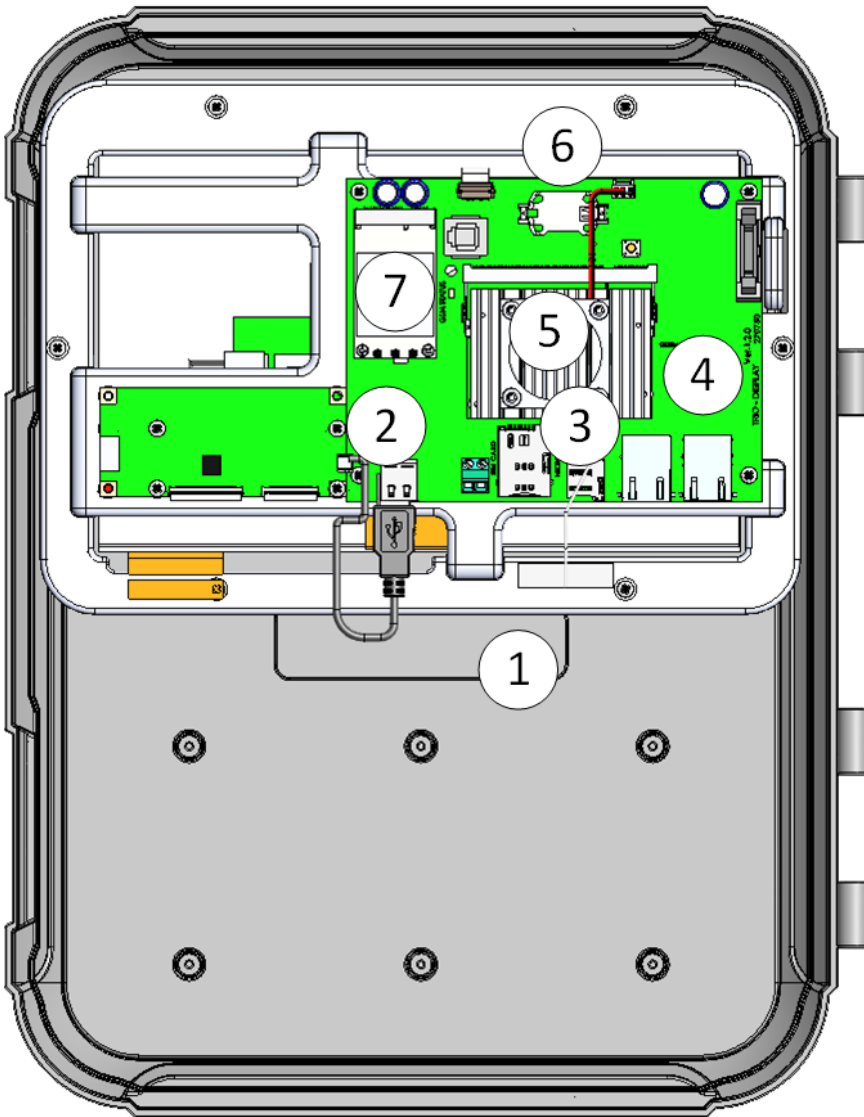

Figure 12: Display Board layout, Display Card Version 1.0.4

1	Wireless antenna
2	SIM Port
3	SD Port
4	Ethernet Port
5	Heat Sink
6	3V Battery
7	Modem

*NOTE There is no functional difference between Versions 1.0.4 and 1.1.0. All future versions will support both cards.*

### 3.4 Wiring Diagrams

- High Voltage Relays
- Alarms and Power
- Internet Connection
- Analog Output Devices
- Digital Devices
- Analog Input Devices
- TRIO RPS
- Silo Wiring
- RSU Wiring

*NOTE* After physically installing and connecting the external input/output devices, perform a Cold Start (System > General Settings > About > Reset Factory Default). Only after the Cold Start do you map the devices.

#### 3.4.1 HIGH VOLTAGE RELAYS

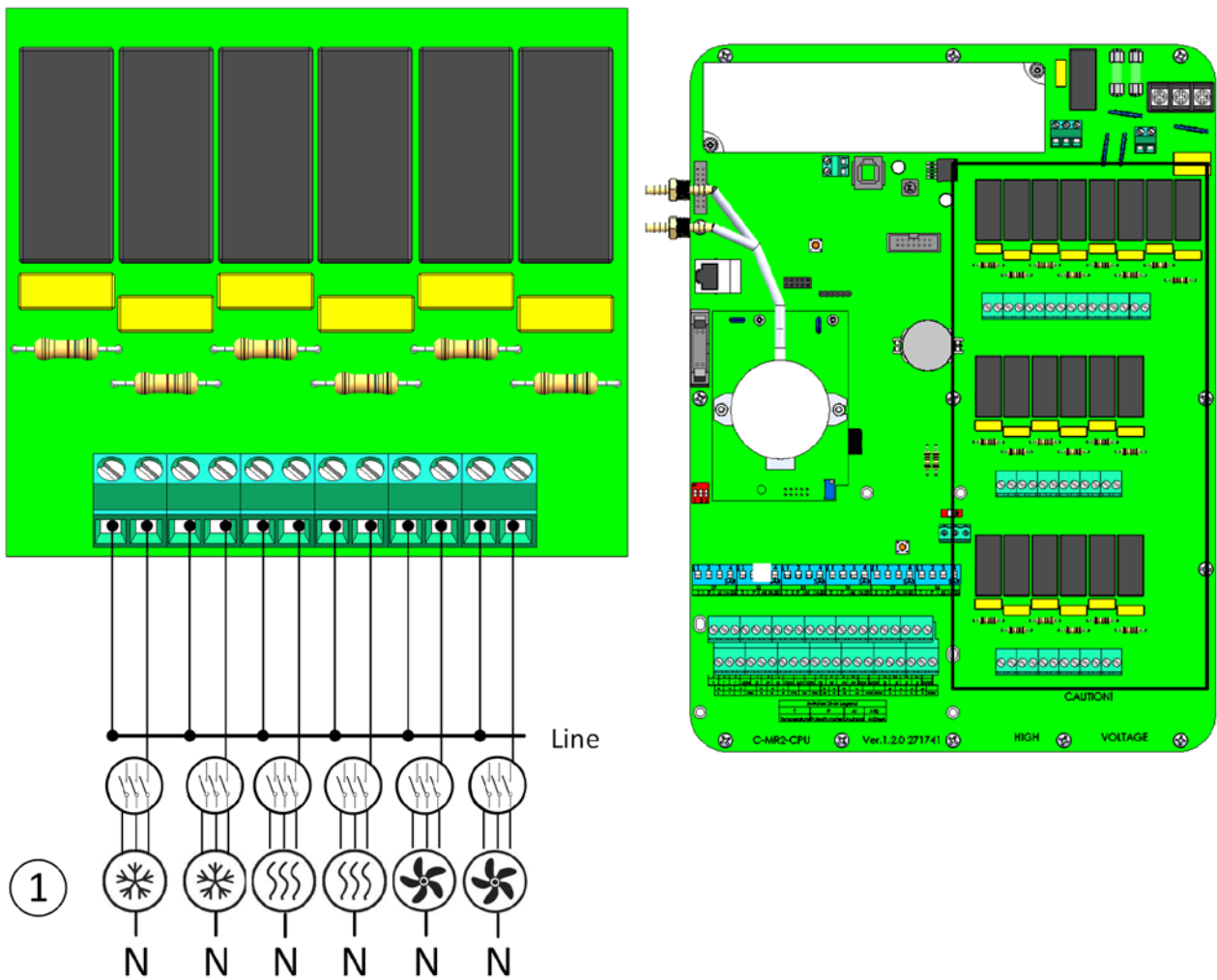

Figure 13: High voltage devices (examples)

1	Example of devices
---	--------------------

NOTE The relays control motors and heating devices via contactors, not directly.

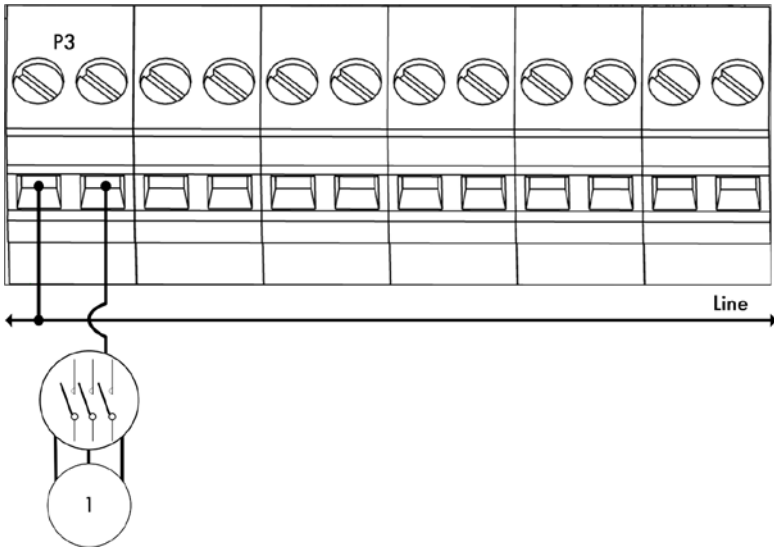

Figure 14: Relay wiring detailed view

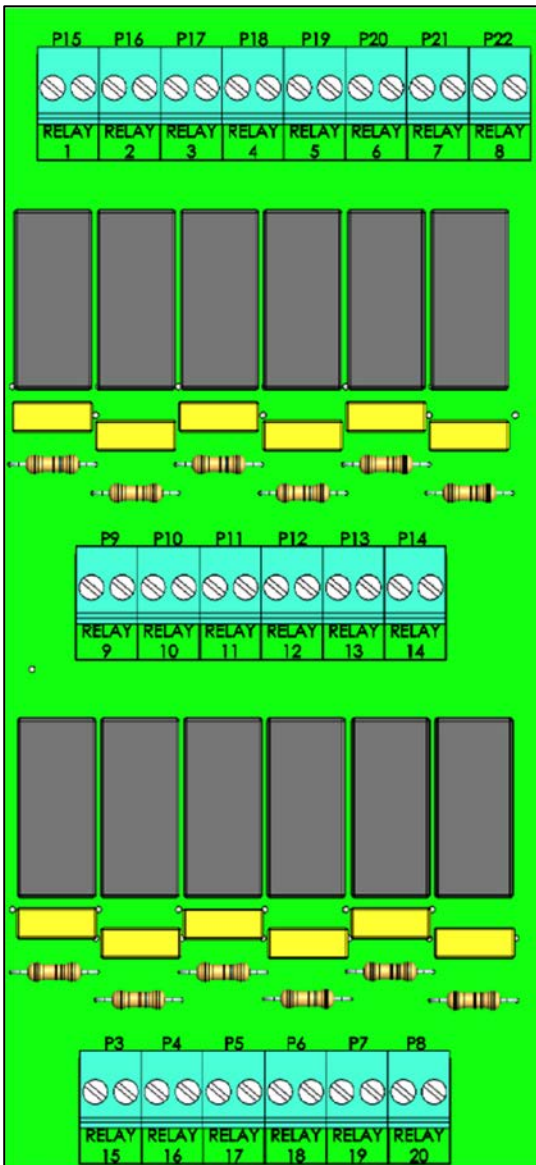

Figure 15: Relay and port numbering

### 3.4.2 ALARMS AND POWER

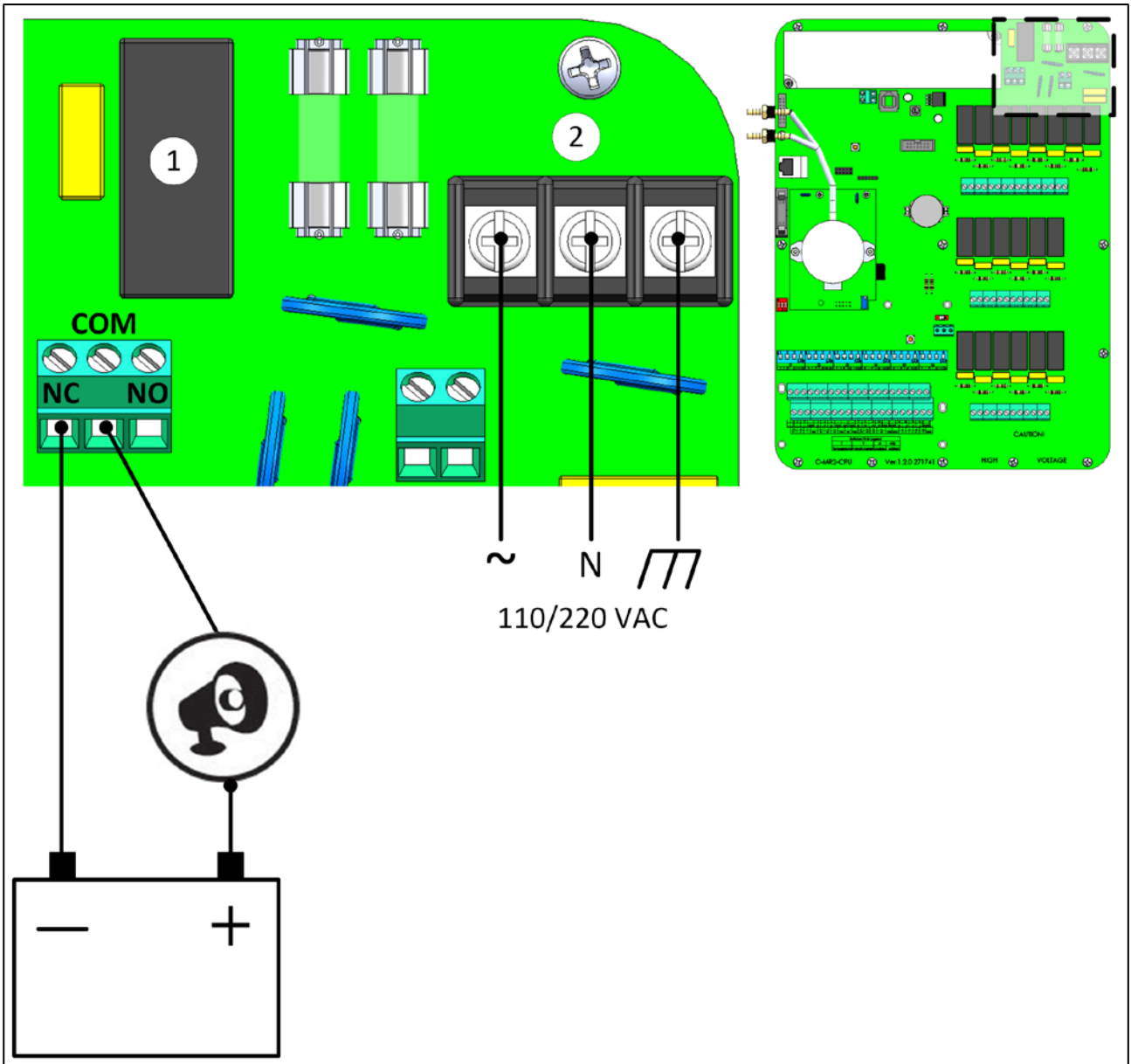

Figure 16: Alarm relay and power ports

1	Alarm relay
2	Power ports

- Connect the light or siren device to the alarm relay.
- Input power can be up to one (1) amp/240 VAC.

NOTE The alarm power source can be AC or DC. The above illustration is an example only.

### 3.4.3 INTERNET CONNECTION

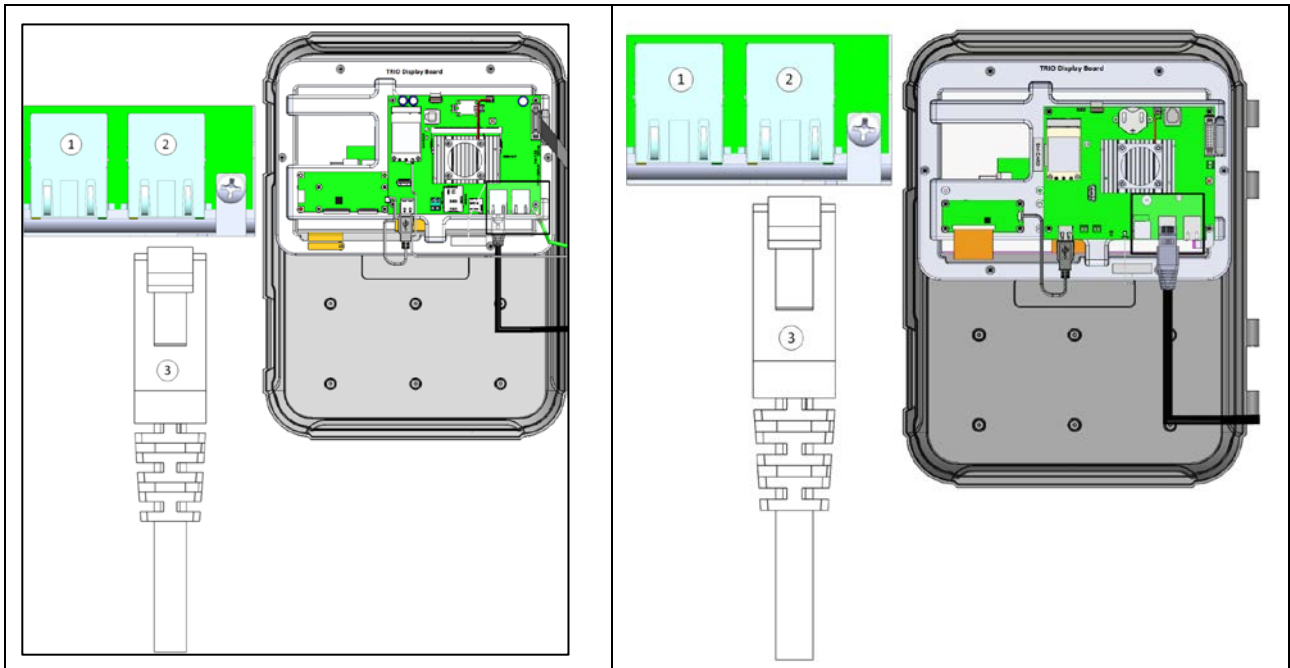

Figure 17: Ethernet port, Display Card Versions 1.0.4 and 1.1.0, Display Card Versions 1.0.4 and 1.1.0

**CAUTION** Connect the internet cable to port 2. Do not connect the cable to port 1.

1	Internal port (do not use this port)
2	Ethernet port
3	RJ-45 cable

### 3.4.4 ANALOG OUTPUT DEVICES

TRIO supports analog control over a variety of devices.

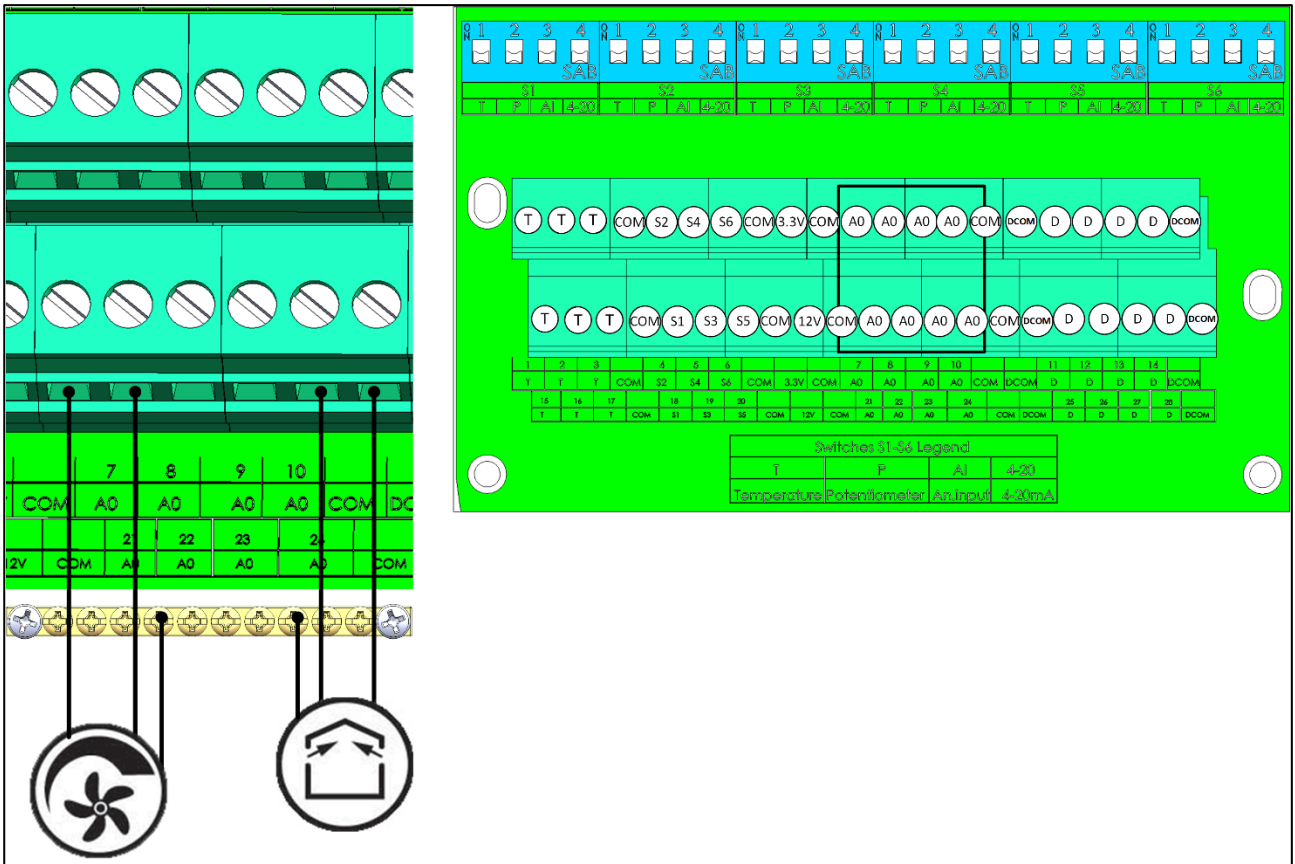

Figure 18: Analog Output devices (examples)

Connect analog output devices to an AO and a COM port. Ground these devices!

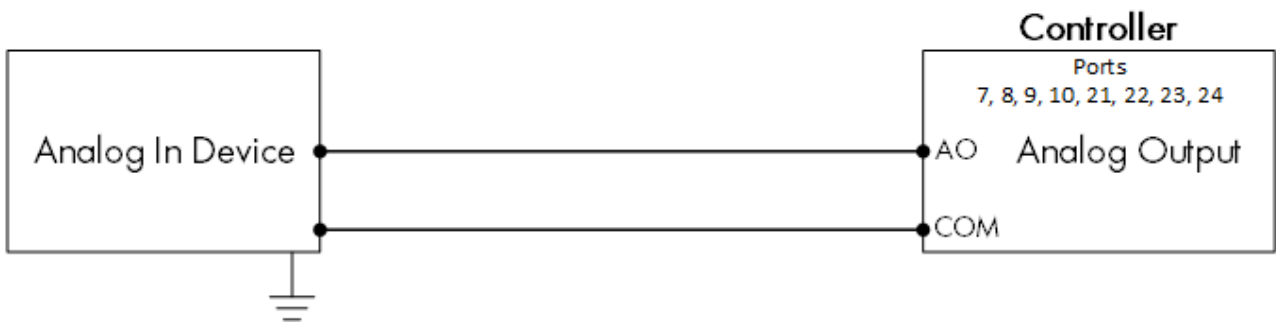

Figure 19: Analog Device Wiring Schematic

**CAUTION** These devices must be wired to a COM port, not a DCOM port.

### 3.4.5 DIGITAL DEVICES

Trio supports power meters, gas meters, water meters, auxiliary inputs, and feeder line sensors.

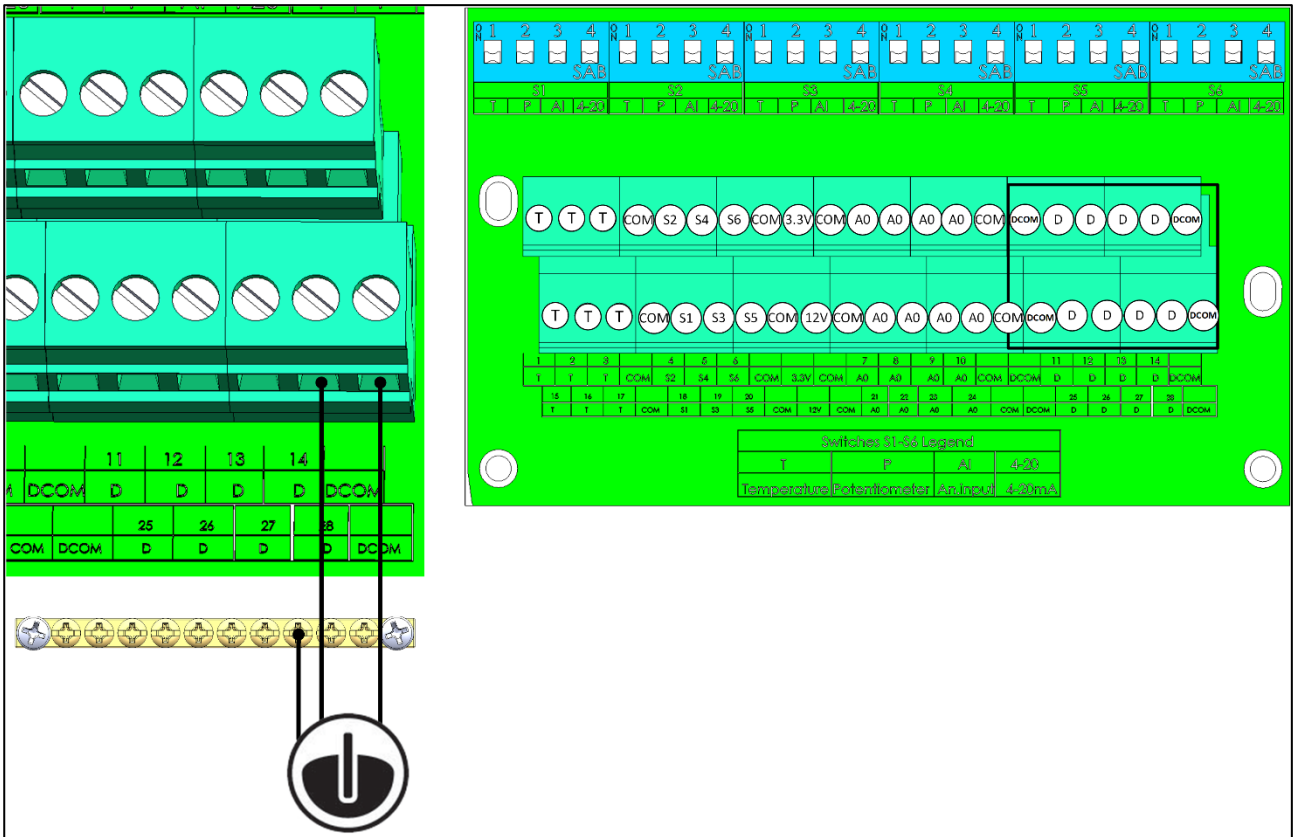

Figure 20: Digital Input devices (examples)

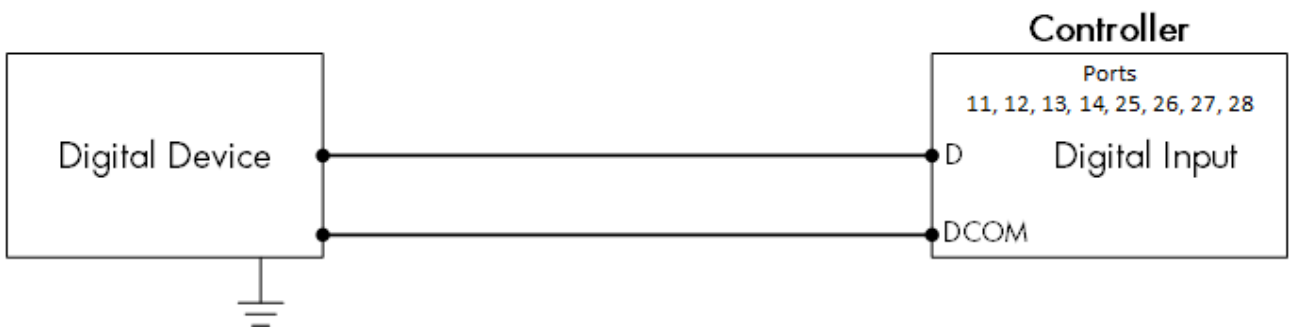

Figure 21: Digital Device Wiring Schematic

- Connect digital devices to a D port and a DCOM port.

**CAUTION** These devices must be wired to a DCOM port, not a COM port.





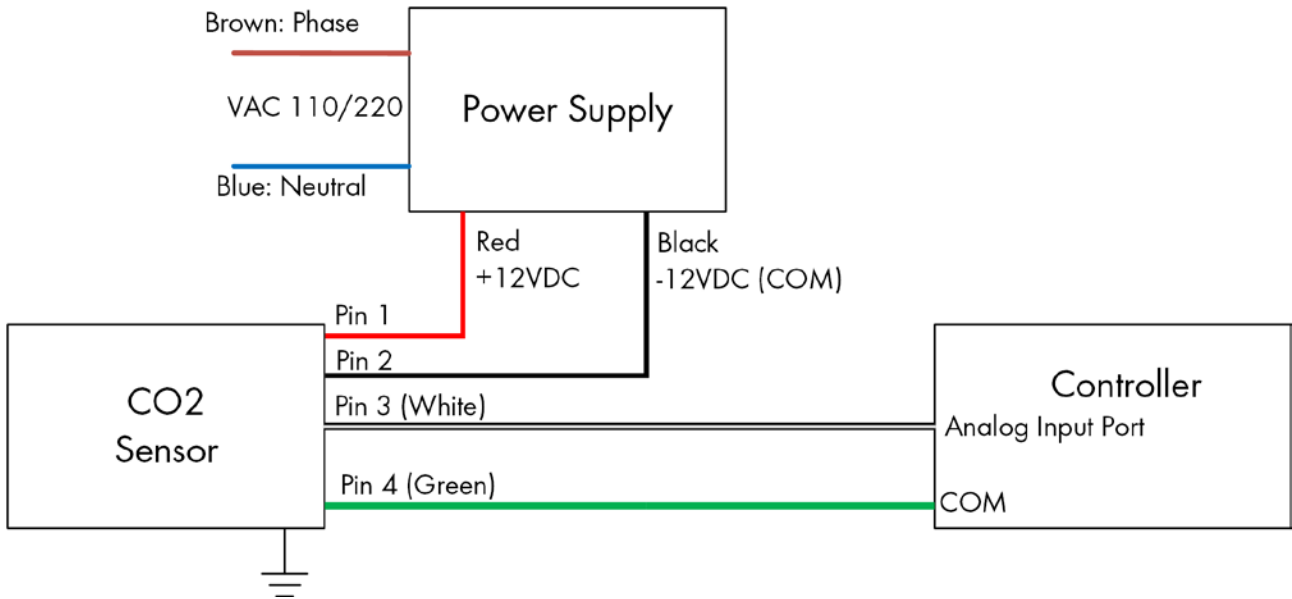

Figure 24: CO2 Sensor Wiring Schematic

- Connect the CO2 device to:
  - Controller:
    - S port. In the corresponding dipswitch, raise dipswitch 4 (4-20 mA).
    - COM port
  - Power supply
    - +12V
    - -12V

### 3.4.6.2 Temperature Sensor Wiring

Refer to the [RTS-2 Manual](#) for details on this sensor.

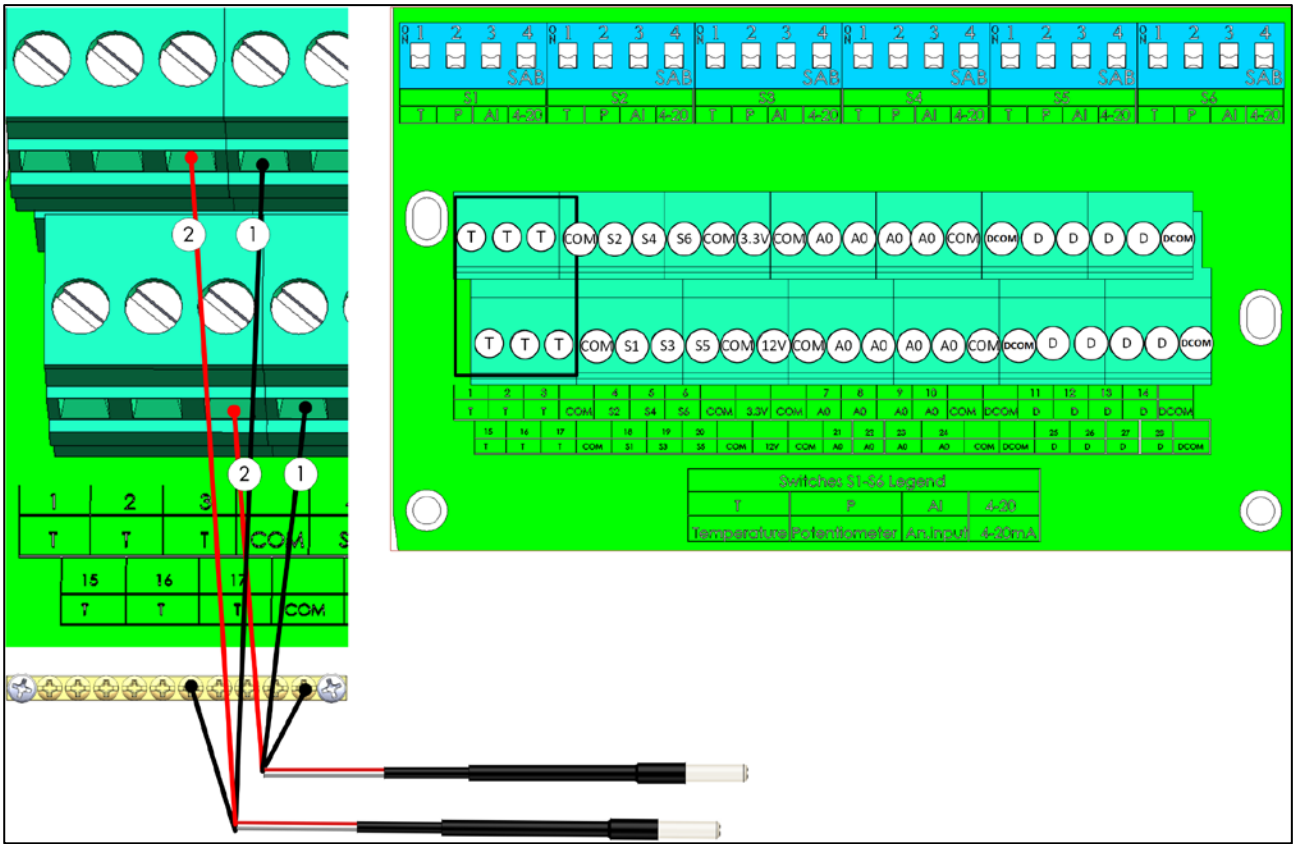

Figure 25: RTS Wiring

Number	Function
1	COM port (black wire)
2	T port (red wire)

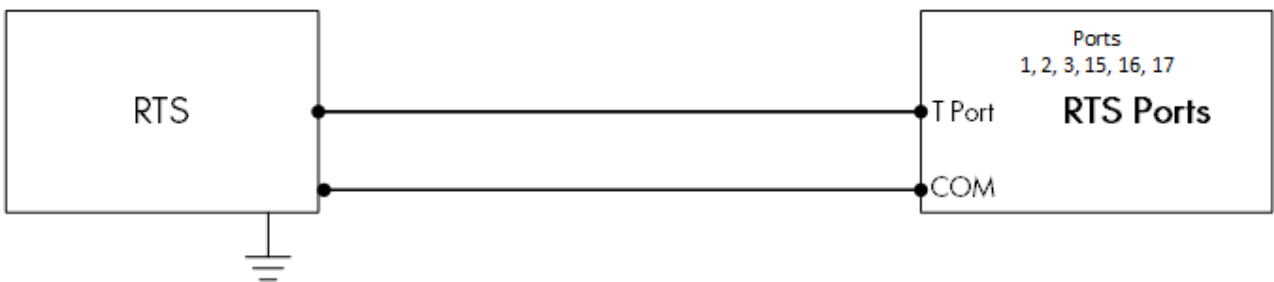

Figure 26: RTS Wiring Schematic

- Connect each RTS sensor to a:
  - T port
  - COM port
  - Grounding strip!
- Notes:
  - Wire all designated T ports before wiring the RTS sensors to the S ports.
  - Connect the black wire to a COM port, not a DCOM port.

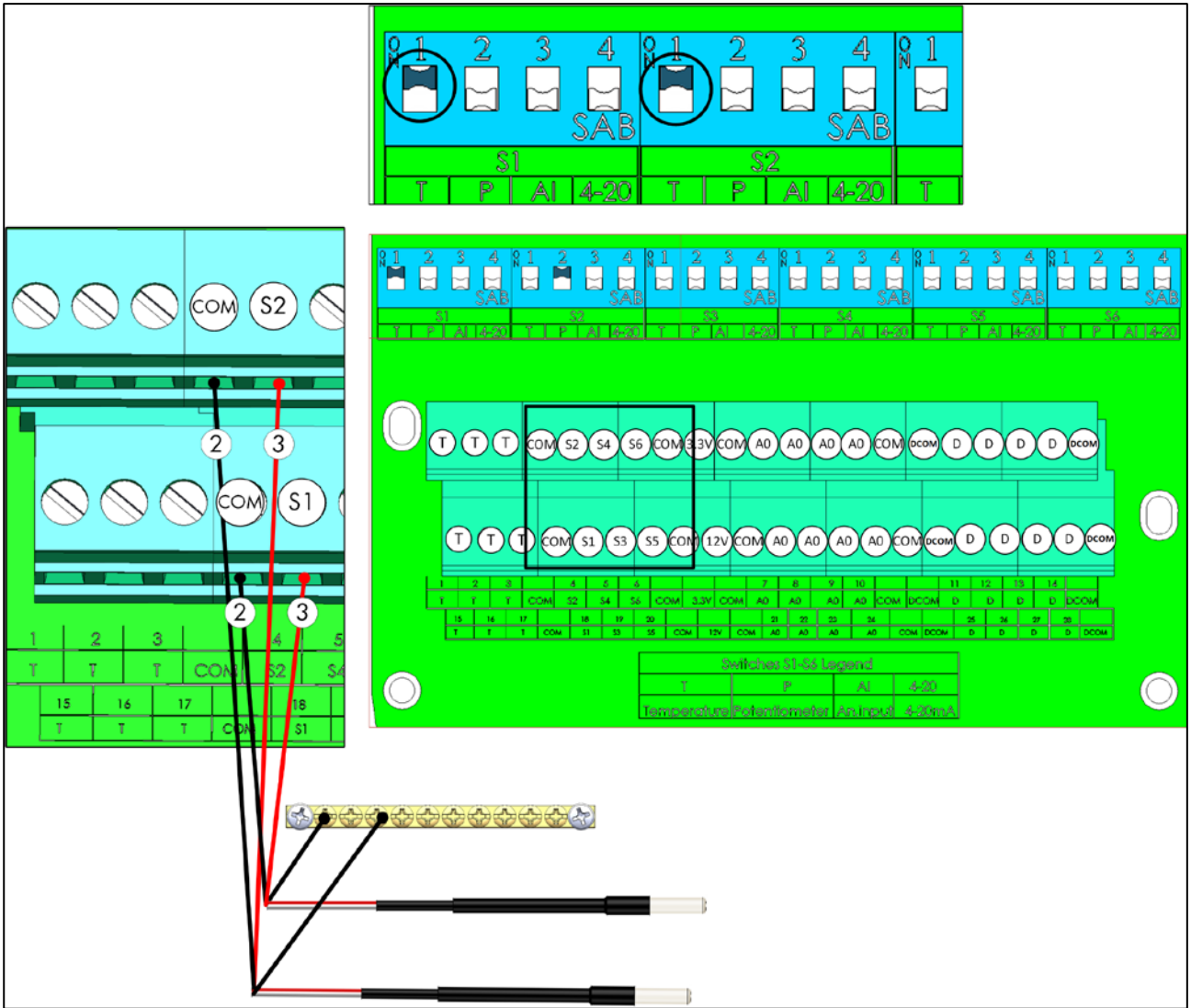

Figure 27: RTS S Port Wiring

Number	Function
2	COM port (black wire)
3	S port (red wire)

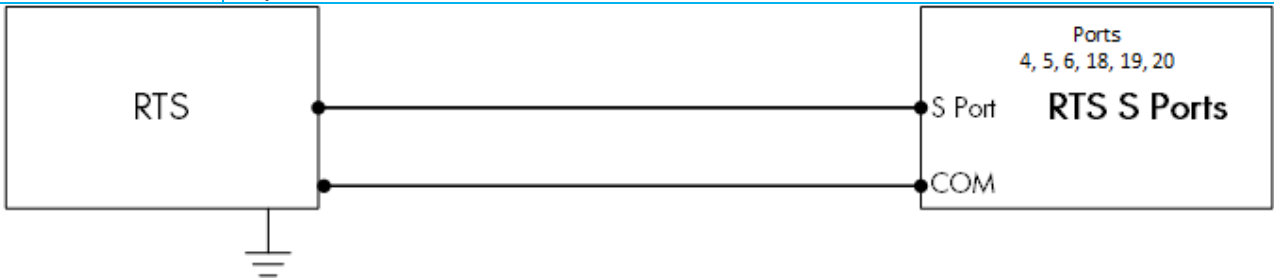

Figure 28: RTS S Port Wiring Schematic

- Connect each RTS sensor to a:
  - S port. In the corresponding dipswitch, raise dipswitch 1 (temp)
  - COM port
  - Grounding strip!
- Note:
  - Wire all designated T ports before wiring the RTS sensors to the S ports.
  - Connect the black wire to a COM port, not a DCOM port.

### 3.4.6.3 Humidity Sensor Wiring

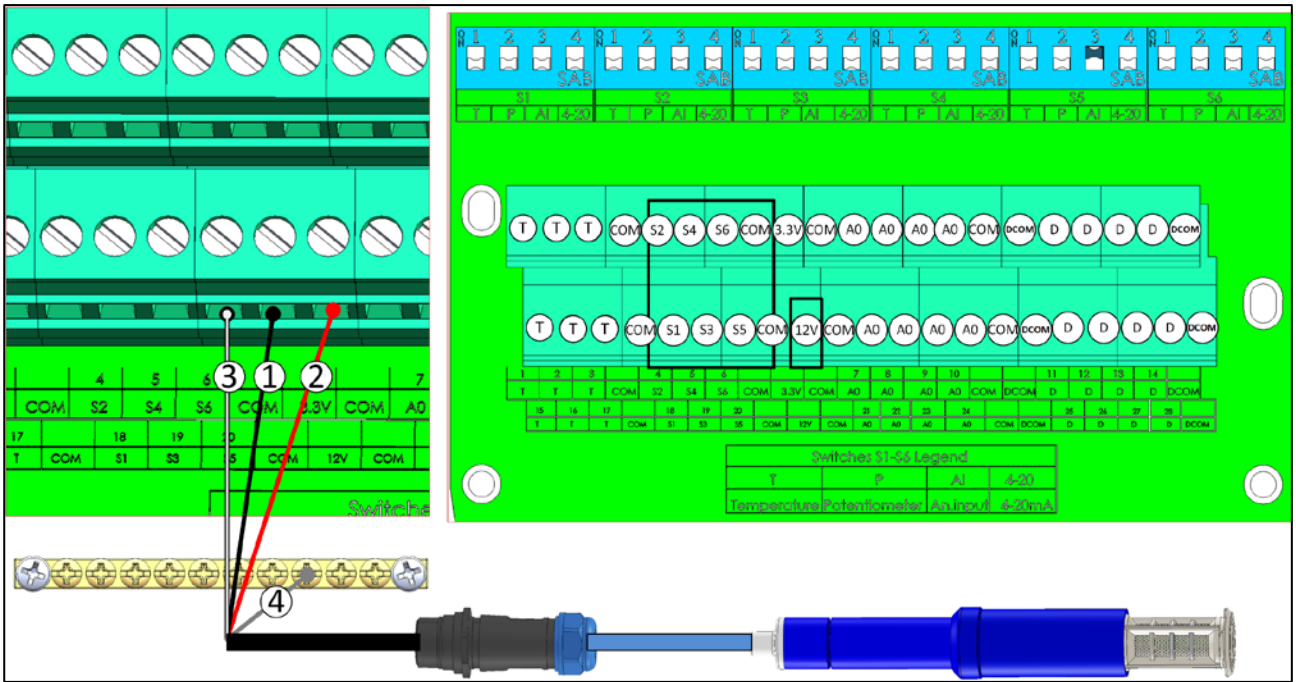

Figure 29: RHS+ Wiring

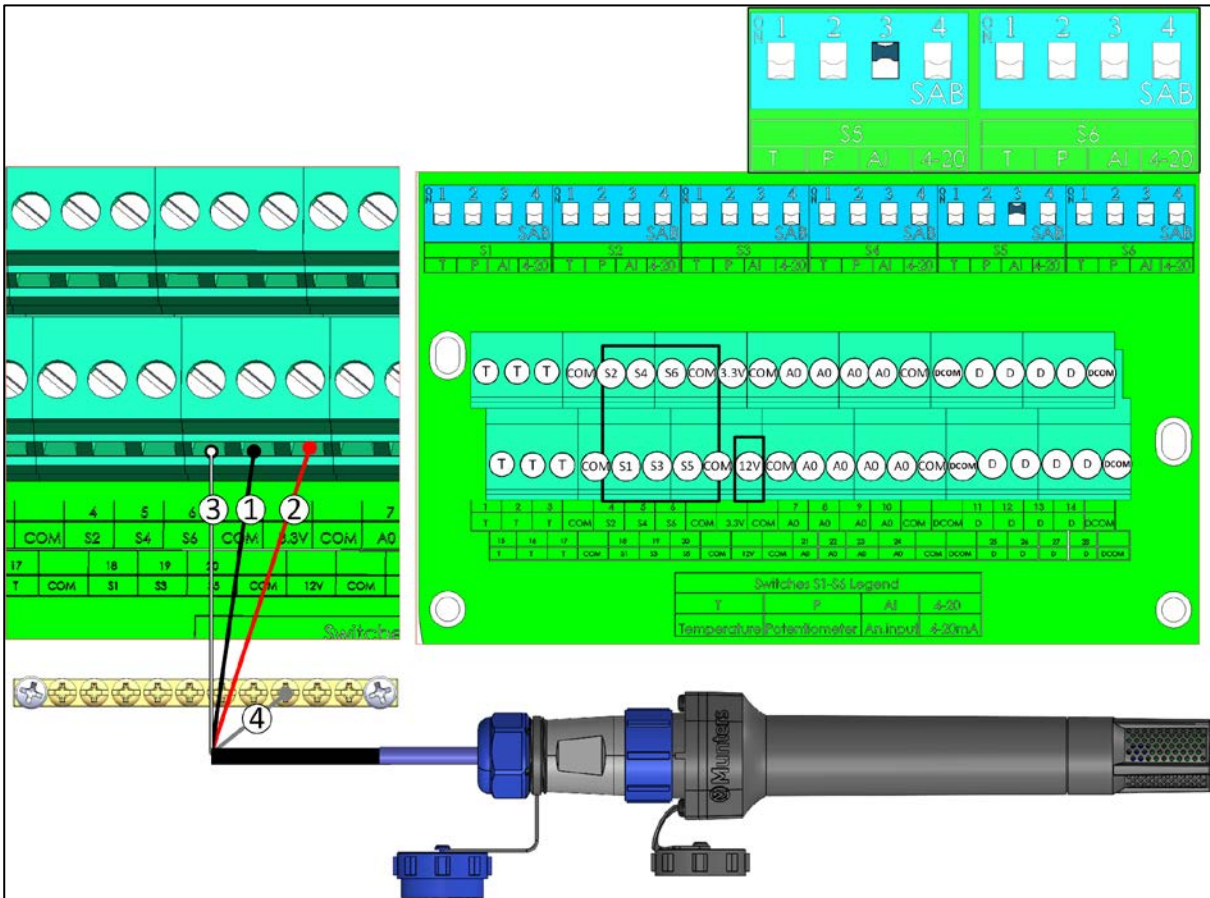

Figure 30: RHS Pro Wiring

Number	Function
1	COM port (black wire)
2	12V (red wire)
3	S port (white wire)
4	Shield wire

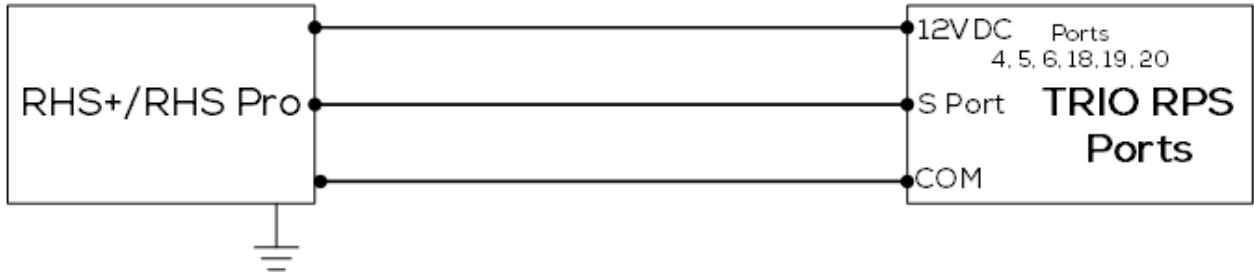

Figure 31: RHS+ Sensor Wiring Schematic

- Connect each RHS+/Pro sensor to a:
  - S port. In the corresponding dipswitch, raise dipswitch 3 (analog input).
  - COM port.
  - 12VDC port.
  - Grounding strip!

### 3.4.6.4 Potentiometer Device Wiring

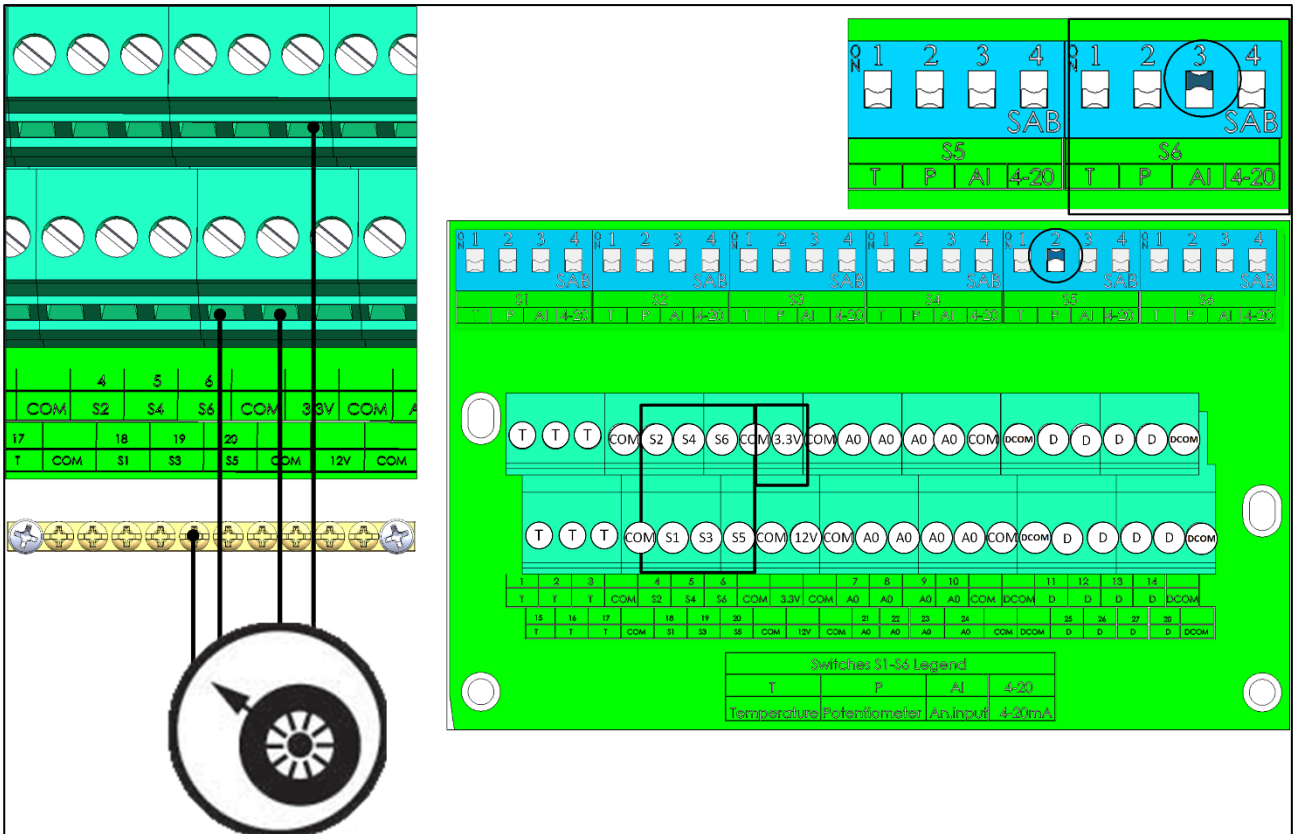

Figure 32: Potentiometer Wiring

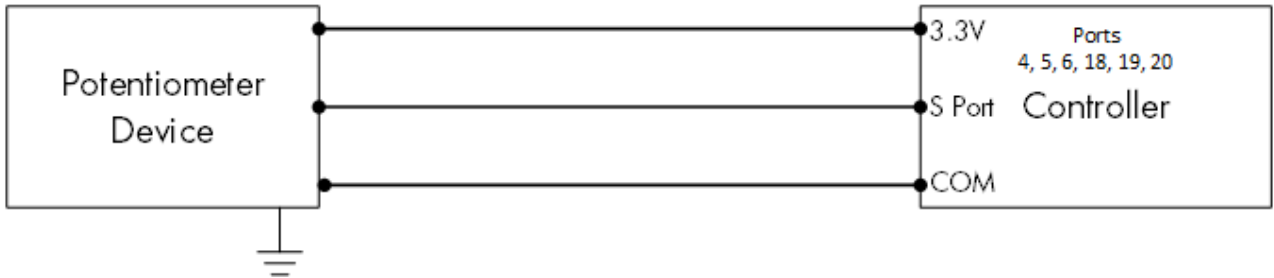

Figure 33: Potentiometer Wiring Schematic

- Connect each potentiometer to a:
  - S port. In the corresponding dipswitch, raise dipswitch 2 (potentiometer).
  - COM port.
  - 3.3V port.
  - Grounding strip!
- Test the potentiometer. Refer to Potentiometer, page 102.

### 3.4.6.5 Ammonia Sensor Wiring

Refer to the [Ammonia Sensor manual](#) for further information.

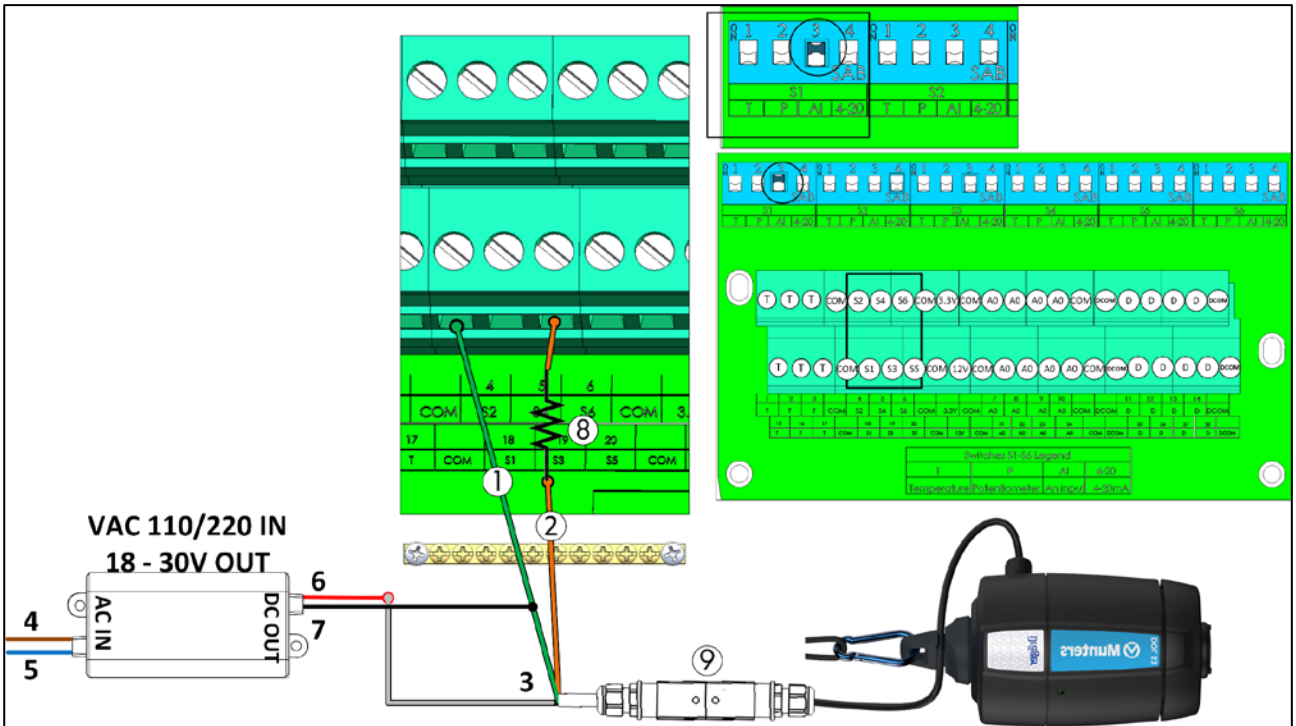

Figure 34: Ammonia Sensor Wiring

Number	Function
1	COM port (Green wire)
2	S port (Brown wire)
3	White wire
4	Phase (Brown wire)
5	Neutral (Blue wire)
6	18-30VDC (Red wire)
7	COM (Black wire)
8	20.3 kohm resistor (Note: The resistor comes supplied with the sensor but must be installed on-site.)
9	Quick connector

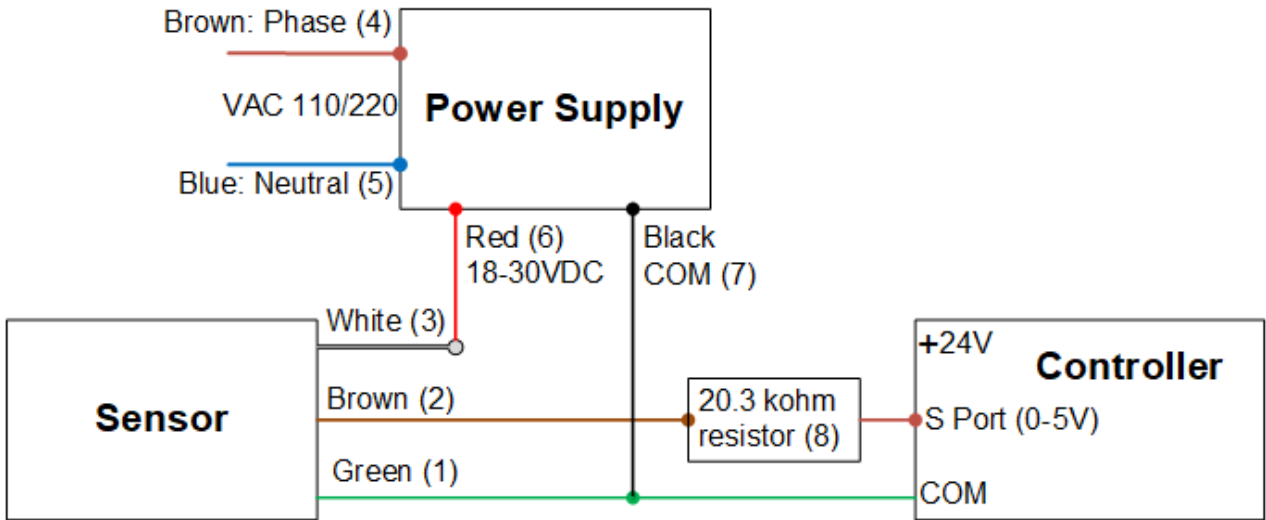

Figure 35: Ammonia Wiring Schematic

- Connect an ammonia sensor to a:
  - S port. In the corresponding dipswitch, raise dipswitch 3 (analog input).
  - COM port.
  - Grounding strip!

### 3.4.7 TRIO RPS

TRIO RPS serves as a second static pressure sensor for the TRIO Controller. The following section details the installation. Refer to the [RPS Manual](#) for more information. TRIO supports up to two static pressure sensors, one built in and one external. Install the RPS in the second room.

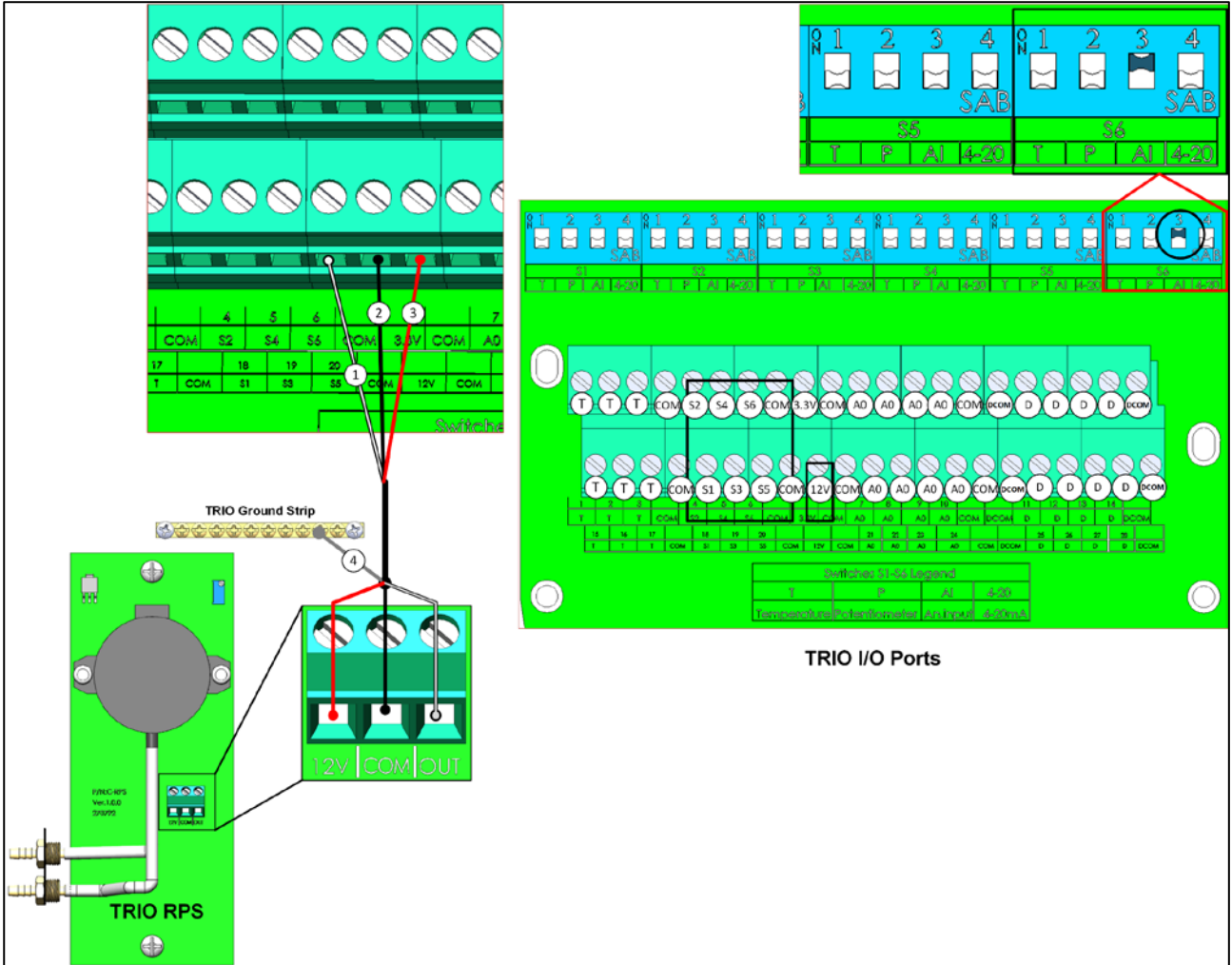

Figure 36: RPS Wiring

Number	Function
1	S port. Raise the corresponding S3 dipswitch.
2	COM port
3	12V
4	Shield wire

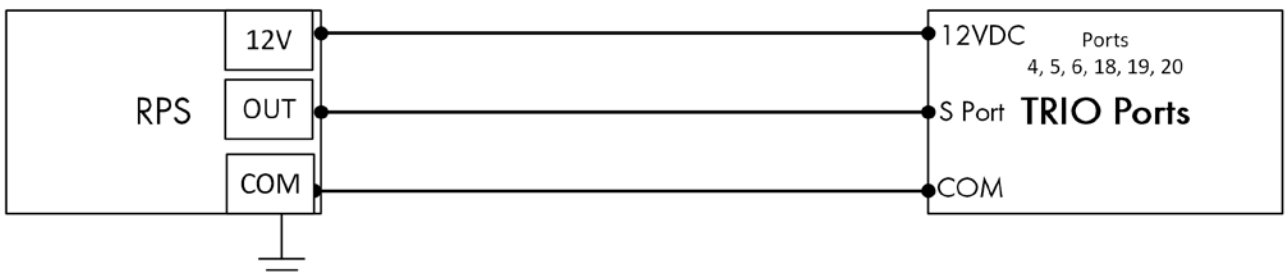

Figure 37: RPS Wiring Schematic

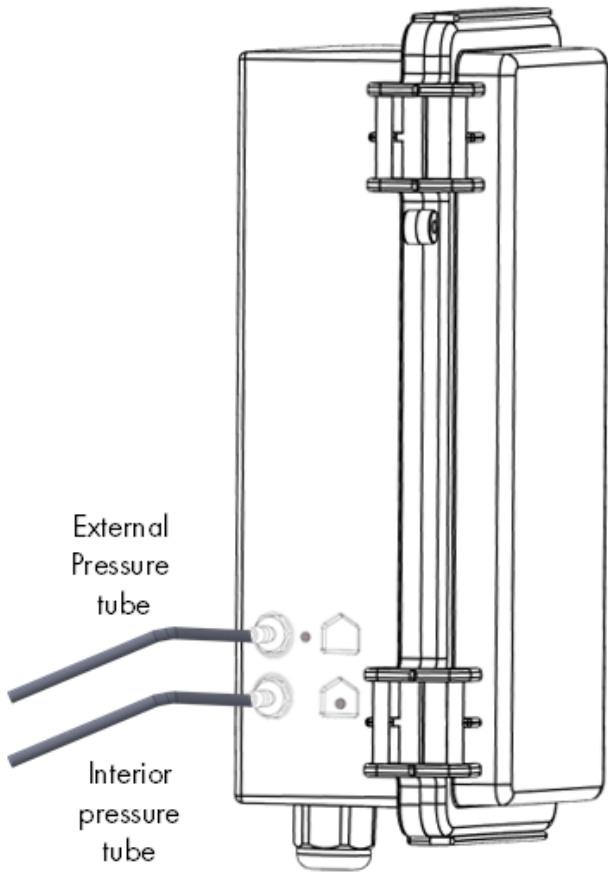

Figure 38: RPS Static Pressure Tubes

NOTE After installing the RPS, no Cold Start is required.

### 3.4.8 SILO WIRING

Wire the Trio to an RJB Junction Box and power supply. For details on how to wire the Junction Box to the load cells, refer to the RJB manual.

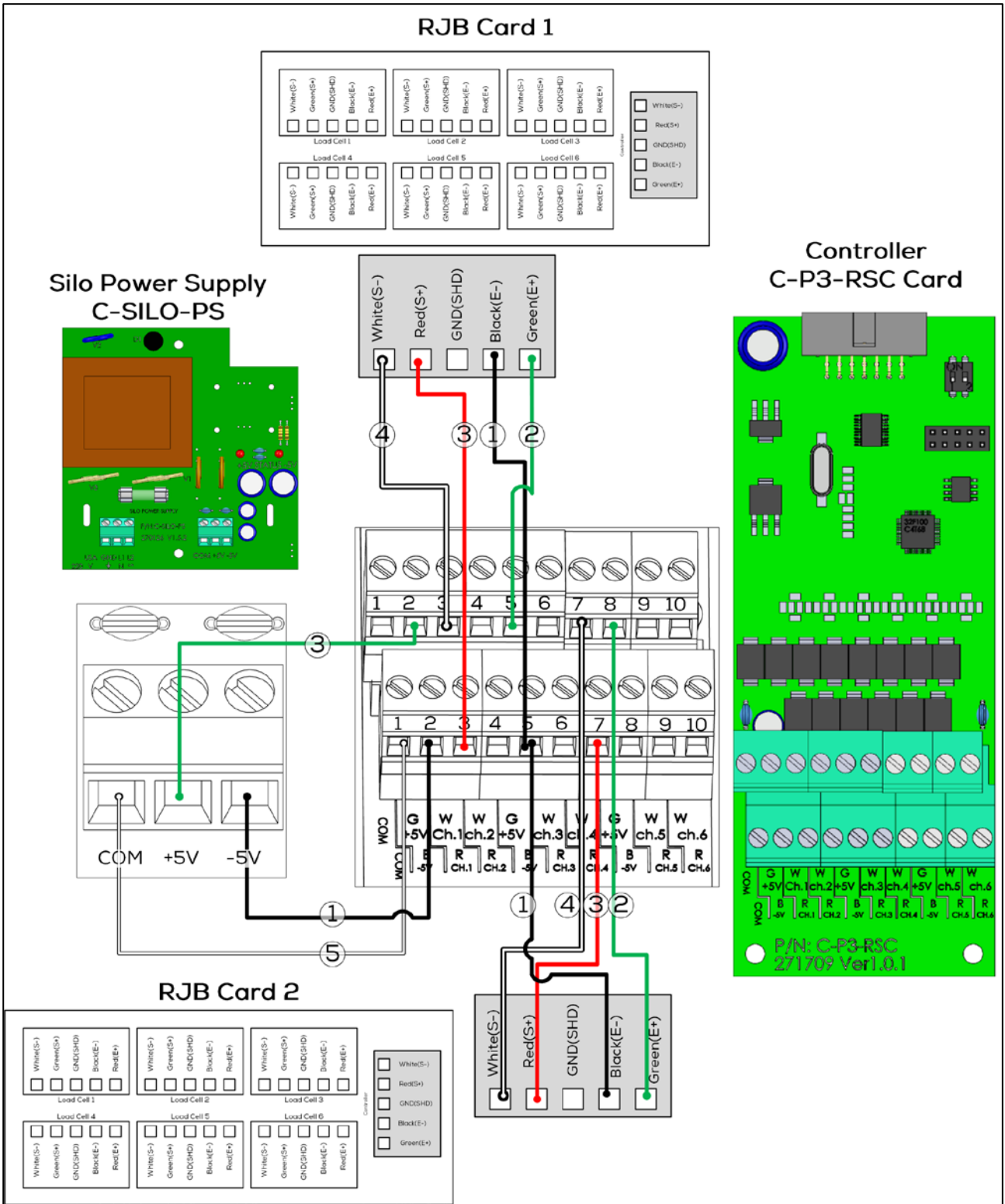

Figure 39: Scale Card Wiring to Power Supply and RJB-6

**NOTE** Connect each RJB-6 white and red wire to matching RSC ports; for example White Ch.1 and Red Ch. 1.

Number	Function
1	Black wire, -5V
2	Green wire, +5V
3	Red, Channel 1 - 6
4	White, Channel 1 - 6
5	COM

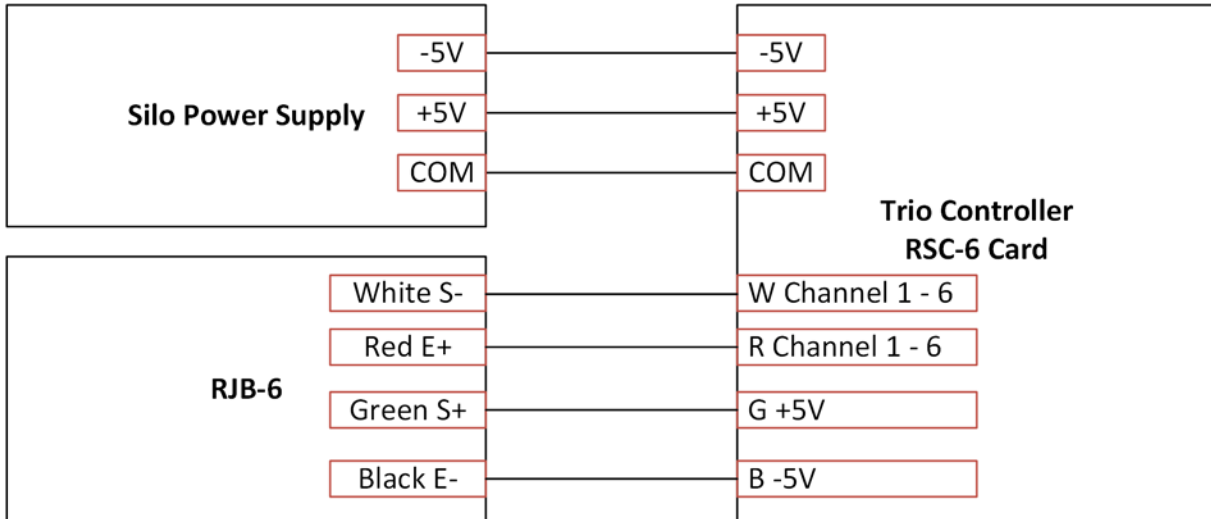

Figure 40: RSC Card to Silo Power Supply/RJB-6 Schematic

RJB Wire	RSC Ports
Green	2, 5, 8 (Upper)
Black	2, 5, 8 (Lower)
White	3, 4, 6, 7, 9, 10 (Upper)
	Note: Connect each RJB white and red wire to matching ports. For example White Ch.1 and Red Ch.1

### 3.4.9 RSU WIRING

Refer to the [RSU Manual](#) for further information.

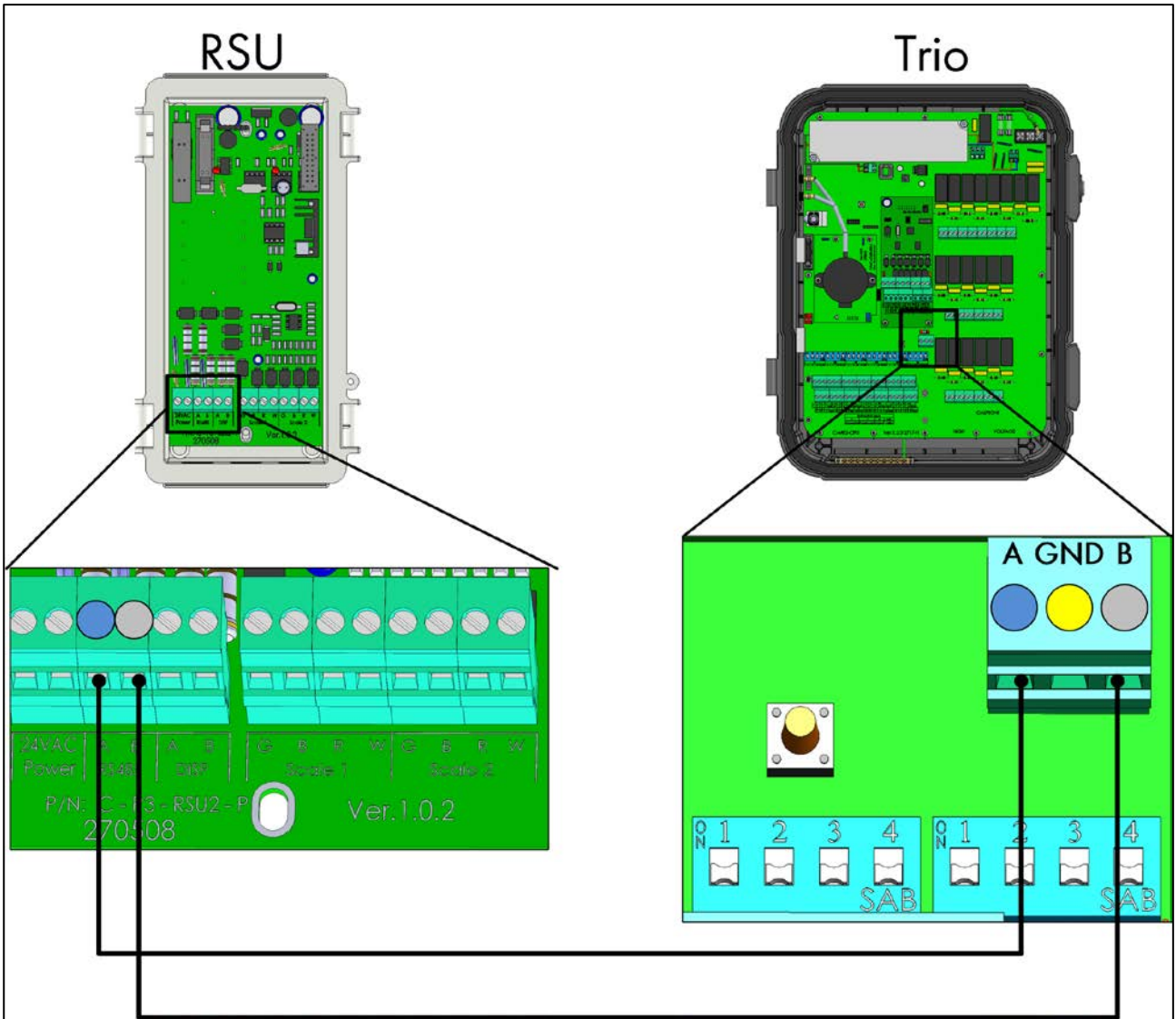

Figure 41: Trio – RSU Wiring

### 3.5 Termination

Termination, installing or enabling 120-ohm termination resistors at the beginning and end units of a chain, ensures reliable communication in RS-485 infrastructures.

Termination is recommended when the distance between Trio and the final device in the chain is more than 50 meters/165 feet. Trio and Trio Expansion come with a switch to enable termination; an external resistor must be installed on the RSU communication card. Termination may not be required in shorter installations.

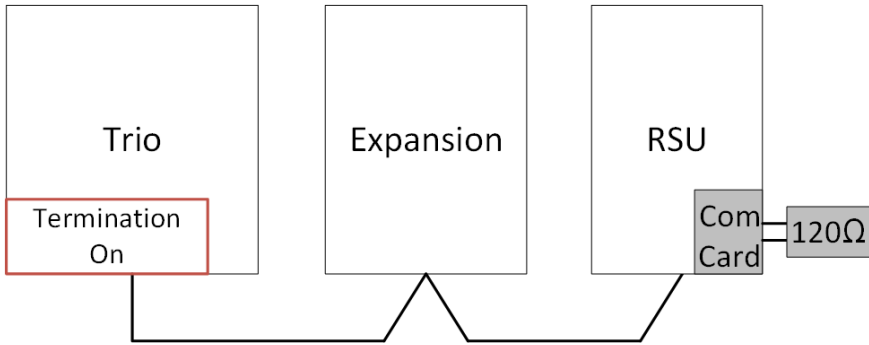

Figure 42: Termination Sample Topology

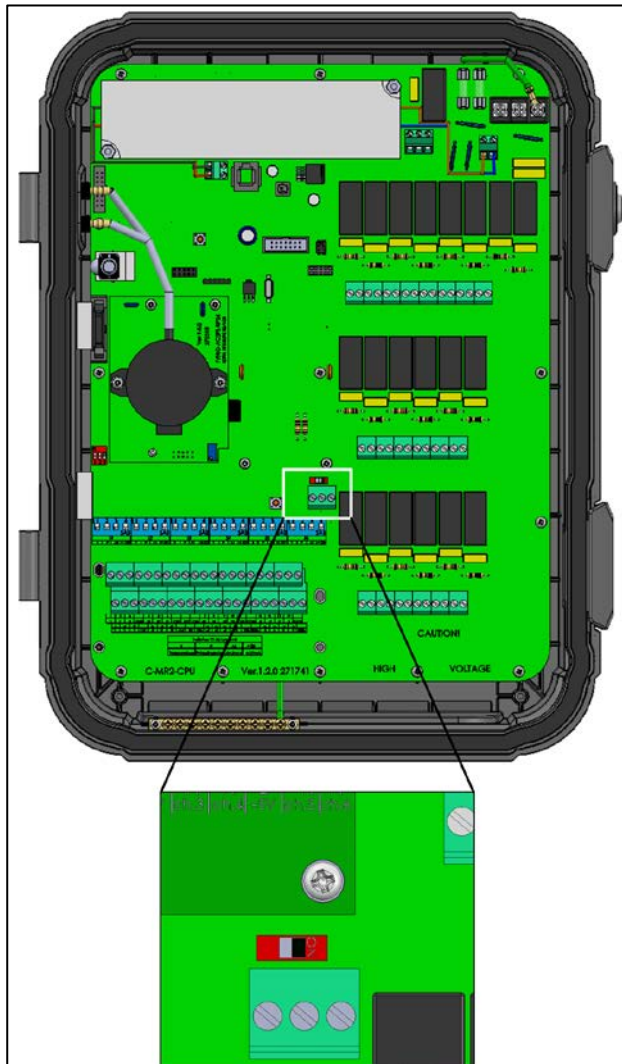

Figure 43: Termination Switch

### 3.6 Pressure Sensor Hoses

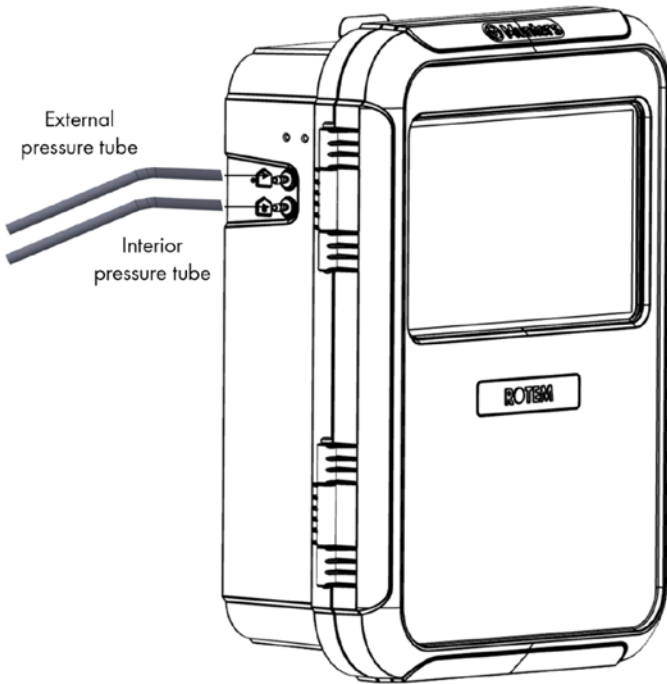

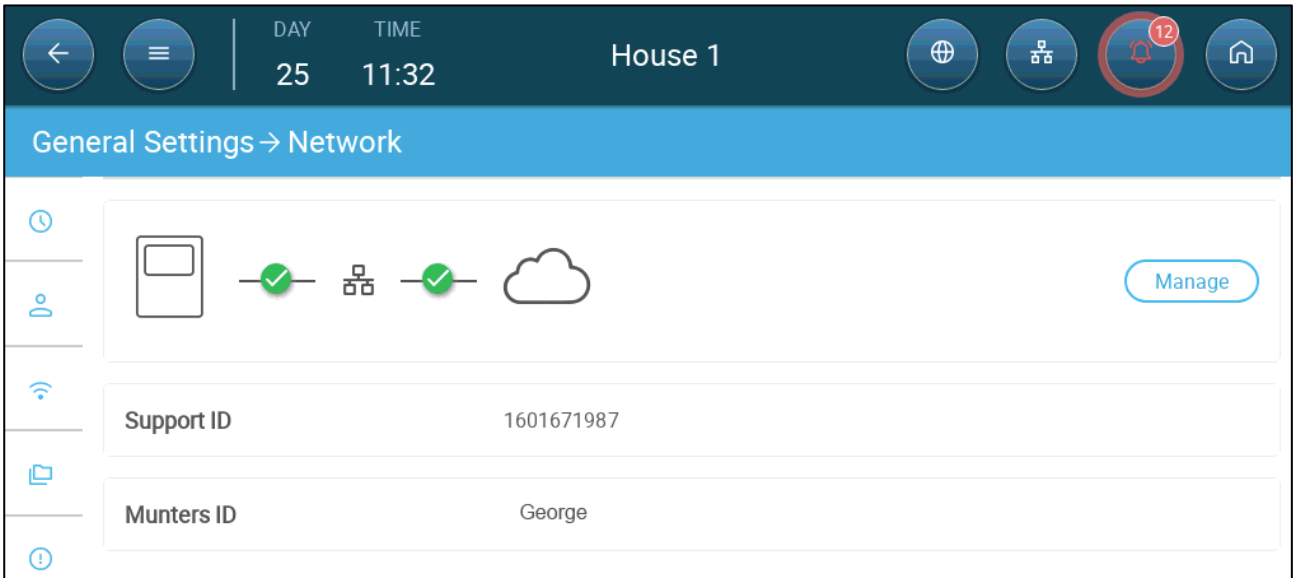

Figure 44: Static Pressure Hoses

### 3.7 Tech Support/Wi-Fi

To view your unit's network information go to System > General Settings > Network . You will need this information when speaking with technical support.



- Click Manage.

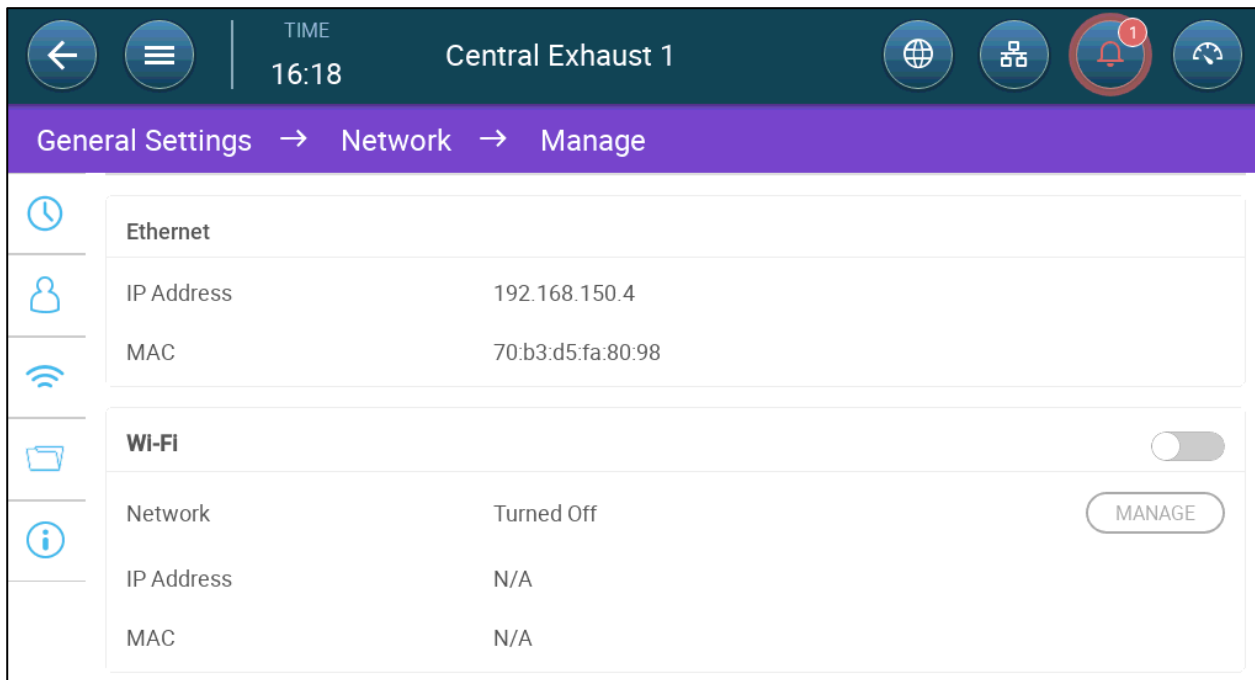

- Ethernet fields are read-only information.
- Enable Wi-Fi if required.

### 3.8 SIM Card Configuration

Trio units come equipped with a modem (including a SIM card and antenna). The Trio modem's SIM card is a global SIM. No configuration is required because the SIM will find the relevant ISP.

- The connection to the Cloud is prioritized: 1) LAN 2) Wi-Fi 3) Cell-modem. The cell-modem connection is active only if the LAN or Wi-Fi are not available.

The SIM card supports three levels of connectivity to the TrioAir application:

- Free: Users subscribed to TrioAir's free plan can register the unit for free. No data plan is required.
- Alarms: Users subscribed to the TrioAir alarm function receive alarms in real-time.
- Data plan: Users can subscribe to the TrioAir Premium access plan, enabling modem access to the TrioAir cloud.

**CAUTION** By default, the cell modem is enabled.

# 4 TrioAir

TrioAir is the Munters (desktop and cellphone) app that gives users remote access to their controllers. Trio Controllers are connected directly to the internet via a standard modem. Trio Air is the application used to manage your controllers via the web. In addition to seamless access to your Trio Controllers, Trio Air also offers:

- Remote control and configuration
- Centralized dashboard used to easily compare farms and their controllers.
- Real-time alarms and notifications
- Various levels of access control

There are four basic steps in setting up TrioAir.

- Access the App
- Sign Up
- Creating and Managing a Farm
- Adding Controllers to Farms

The following sections give basic information on signing up for Trio Air and adding controllers to the system. For more information, refer to the [Munters Zendesk](#).

## 4.1 Access the App

The first step in using TrioAir is to access the application, either on your PC or your cellphone.

- [Desktop App](#)
- [Cellphone App](#)

Users wanting to use TrioAir on their computer, go to <https://www.trioair.net>. Alternatively, you can download the app to your smart phone here:

- [Google Play](#)
- [Apple Store](#)

## 4.2 Sign Up

In using TrioAir, the first step for any user is to create an account. Once this is done, you can be invited to join farms or create your own farms. The creation process is fairly standard and should be familiar for anyone who has ever created an account for any application.

Note: Munters recommends using Google Chrome.

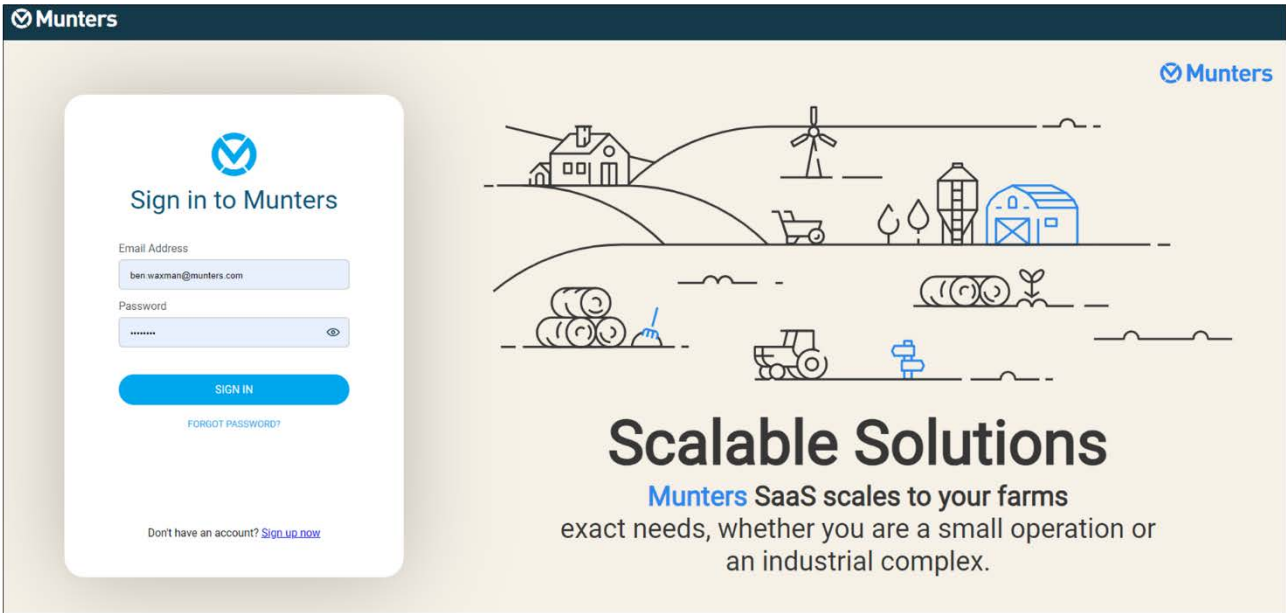

1. Click Sign up now.
2. Enter an email address.
3. Follow the online instructions.
4. Once these steps are completed, an account is created.

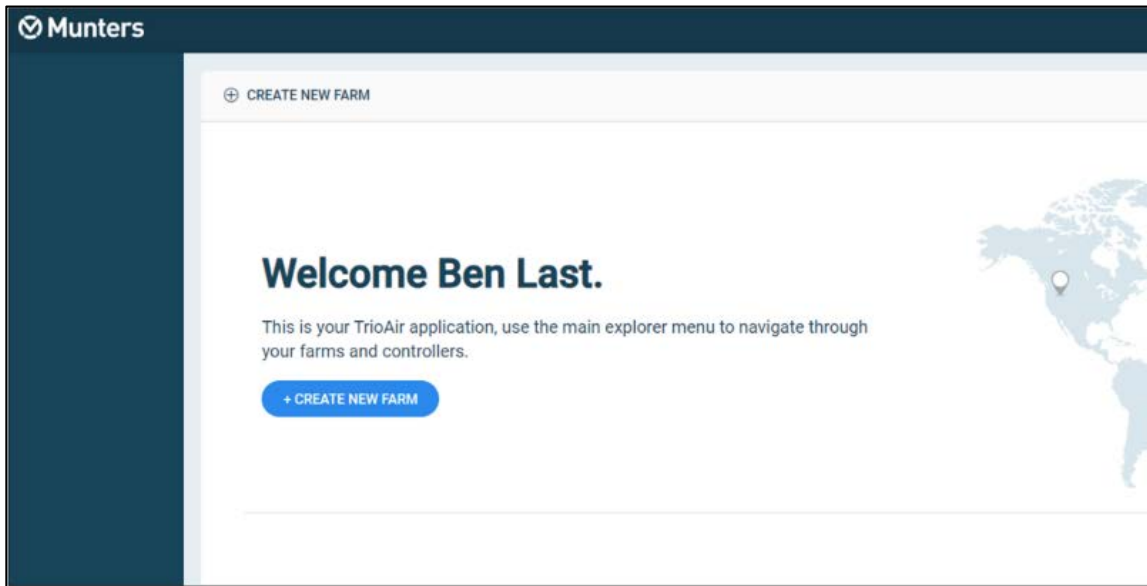

### 4.3 Adding a Controller to a Farm During Installation

*NOTE The following procedure requires that the Trio be connected to the internet. If the unit is offline, refer to Offline Registration.*

The first time that a user power ups a Trio, the following Welcome Screen appears.

# Welcome To Trio Controller!



## Before using your Trio, please register the controller with TrioAir.

Registration enables access to the following features:



### Remote Access

Monitor and control your farm remotely and in real-time.



### Manage Data

Access your farm data.



### Data Insights

Receive data-driven insights needed to make informed decisions.



### Remote Control

TrioAir enables remote control over your controllers in multiple manners.

SKIP FOR NOW

GET STARTED

1. Click Get Started. (If you do not want to register the unit at this time, click Skip For Now). The following screen appears.



## TrioAir Registration



P2M58L796

### To begin the registration process, follow the instructions below.

Note: You must have a TrioAir account to start this process.

1. On your smartphone or desktop, log into TrioAir.

2. Using a smartphone: Scan the QR code. -Or- Using a desktop: Go to Farm Settings > Add New Device. Enter the code manually.

3. Follow the on-line instructions.

2. Follow the instructions on the page. You will need to:

- Select the farm (if there is more than one) to which this Trio is to be added
- Agree to the Terms of Use.

**NOTE** For more details on the on-line registration process, click [here](#).

NOTE If you do not want to register the unit at this time click **Skip For Now**. The Trio Dashboard shows that the unit is not registered. Click that message to register the Trio.

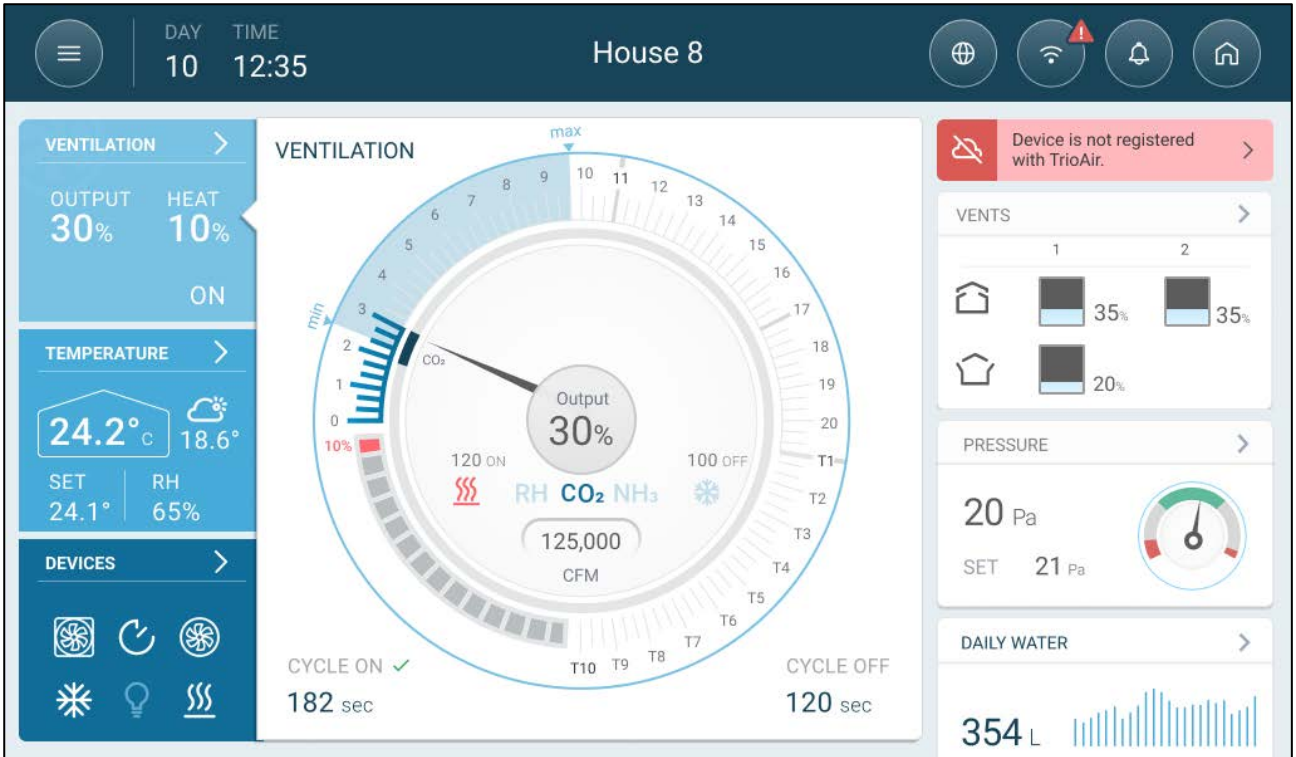

### 4.4 Offline Registration

If the Trio unit is off-line, that status appears on the registration screen.

The screenshot shows the 'Welcome To Trio Controller!' registration screen. It features a blue background with a white warning icon in the top right. The main text reads:   
 - **Welcome To Trio Controller!**   
 - **Before using your Trio, please register the controller with TrioAir.**   
 - Registration enables access to the following features:   
 - **Remote Access:** Monitor and control your farm remotely and in real-time.   
 - **Manage Data:** Access your farm data.   
 - **Data Insights:** Receive data-driven insights needed to make informed decisions.   
 - **Remote Control:** TrioAir enables remote control over your controllers in multiple manners.   
 - A red warning banner at the bottom states: **Your device is not connected to the internet.** Please connect your device or click Manage Network.   
 - Navigation buttons at the bottom include 'SKIP FOR NOW', 'MANAGE NETWORK', and 'OFFLINE REGISTRATION'.

1. Click Offline Registration. The following screen appears.

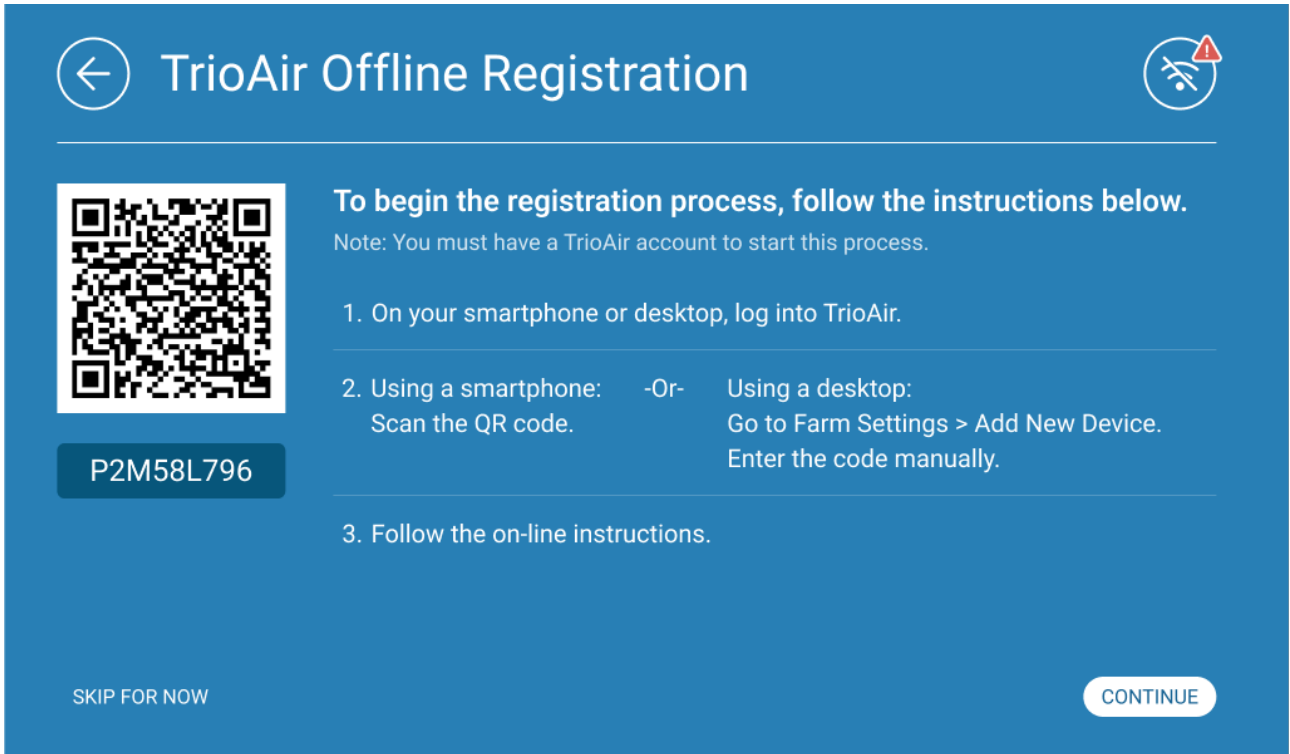

2. Click Continue. Follow the online instructions.





*NOTE* For more details on how to register the Trio while offline, click [here](#).

# 5 Specifications

- Trio Specifications
- Specification Details
- External Devices Specifications

## 5.1 Trio Specifications

Description	Specification
Input Power Voltage	<ul style="list-style-type: none"> <li>• 100 – 240 VAC</li> <li>• 50/60 Hz</li> </ul>
Input AC Power	0.35A (at full load)
Relay Rating	15A
Maximum Relay Load	1 Amp. Up to 60% of the relays can operate at any given time.
<i>Note: Running relays at the above current levels provides between 50,000 – 100,000 switching operations.</i>	
Analog Inputs	0 – 3.3 Volts
Analog Output	0 – 10 Volts; maximum load: 20 mA
Digital Inputs	3.3 Volts, 1.5 mA, dry contact
Communication	<ul style="list-style-type: none"> <li>• LAN – Standard 10/100 BaseT</li> <li>• Expansion – RS-485: 115 Kbps, 8 bit, even parity</li> </ul> <p><i>NOTE Refer to Appendix E: IT Setup, page 149 for more details.</i></p>
Operating and Storage Temperature Range	-10° to +50° C (+14° to +125° F)
Environmental Specifications	<ul style="list-style-type: none"> <li>• Altitude: -400 m to 2000 m</li> <li>• Relative Humidity: 20% - 70%</li> <li>• Main supply voltage fluctuation up to 5%</li> <li>• Overvoltage category II</li> <li>• PD: 2</li> </ul>
Enclosure	<ul style="list-style-type: none"> <li>• Water and dust tight</li> <li>• Indoor use only</li> </ul>
Dimensions (H/W/D)	403 x 324 x 141 mm/16 x 13 x 5.6 inches
Fuses	Fuse F2 & F4 on PS card: 3.15A, 250V

Description	Specification
Power Cable	<ul style="list-style-type: none"> <li>• Copper, 3-wires Phase, Neutral, Ground, 18 AWG minimum</li> <li>• 600V insulation</li> </ul>
Certification	   

## 5.2 Specification Details

- **Disconnection device/overcurrent protection:** The disconnect device in the building installation must be provided according to national regulations and using a certified 2-pole circuit breaker rated 10A, certified in accordance with the IEC standard 60947-2 (in the US and Canada use a Listed Branch Circuit protective circuit breaker). This step is required to provide overcurrent protection and mains disconnection. The circuit breaker must be easily accessible and marked as the controller disconnect device.
- **Main Supply Voltage:** Permanently connect the controller to the mains in accordance with the relevant national code. Provide fixed wiring inside a flexible conduit. Relays must be suitably protected against overcurrent, using a circuit breaker rated at 10A.
- **Keep the units closed and locked.** Only authorized personnel should open and close the units.

## 5.3 External Devices Specifications

Table 1: Summary

I/O type	Qty
Analog Output	8
Analog Input	6
Digital Input	8
Temperature Sensors	12 maximum (6 dedicated, 6 optional)

Table 2: Output Devices

Device type	Maximum Number of Devices	Number of Relay Devices	Number of Analog Devices
Cooling	2	2	N/A
Central Exhaust Cooling	2	2	N/A
Heaters	6	6	6
Inlets	2	2	2
Outlets	1	N/A	1
Tunnel Doors/Curtains	2	2	2

Device type	Maximum Number of Devices	Number of Relay Devices	Number of Analog Devices
Fans Exhaust/Tunnel	20	20	8
Blowback Fan	1	1	N/A
Central Exhaust Fans	20	20	8
Stir Fan	1	1	1
Sprinkler	1	1	N/A
Timer	5	5	N/A
Feeder	1	1	N/A
As Relay	20	20	N/A
As Analog Out	8	NA	8
Alarm	1	1	N/A

Table 3: Sensors

Device type	Analog Sensors	Digital Sensors
Temperature Sensors	12	N/A
Humidity Sensors	2	N/A
Outside Humidity Sensor	1	N/A
CO2 Sensor	1	N/A
Ammonia Sensor	1	N/A
Pressure Sensors	2	N/A
Potentiometers	4	N/A
Silos	3	N/A
Power Meters	N/A	2
Water Meters	N/A	4
Gas Meters	N/A	3
Aux. Input	N/A	4
Feed Active Sensor	N/A	1
Feeder Line Sensor	N/A	1
Measuring Fan	N/A	1

Table 4: Other Devices

Device type	Number
RSU-2 Remote Scale Unit	2

# 6 Using the Trio Touch Screen

	Go back to the previous screen
	View the Main menus
	Choose language
	Network settings
	View alarms
	Go back to the main screen
	Settings icon
	Edit parameters
	Function settings
	Function test
	Replace the dashboard battery with a standard 3V RENATA-CR2450N battery only.
	Click this icon to delete data stored on that page.

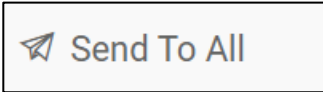
Phone App	
	Click the circle containing the user name to edit personal preferences such as the language, units, name, and more.
	When a Trio controls two or more rooms or there are two or more houses on a farm, Send to All enables editing certain select functions in more than one room or house. Edit the setting, click Send to All, and select the required Trios. The select rooms' or houses' settings are updated. Note: Send to All does not appear on every screen.

# 7 Mapping and Defining the Input Output Devices

**NOTE** Munters recommends that a trained technician perform the following operations.

- Using the Mapping Screen
- Editing the Relays and Sensors
- Defining Sensors
- Defining Devices
- Mapping the Weighing Devices
- Trio RPS
- Testing Devices

## 7.1 Using the Mapping Screen

After wiring devices to the TRIO, each device must be mapped and then defined. Mapping and defining devices enables the system software to control each device's functionality.

**CAUTION** Mapping *MUST* match the physical wiring! An error message appears if the physical device is not wired to the relay or port as defined on the mapping screen.

**To map the devices:**

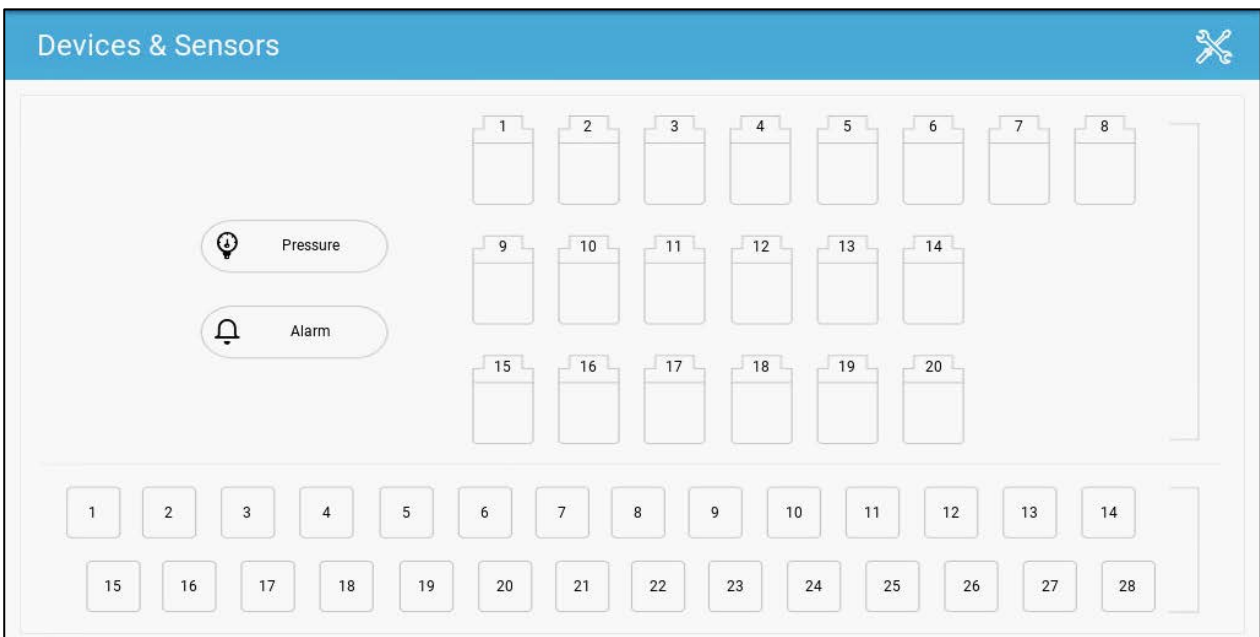

1. Go to System > Device and Sensors.

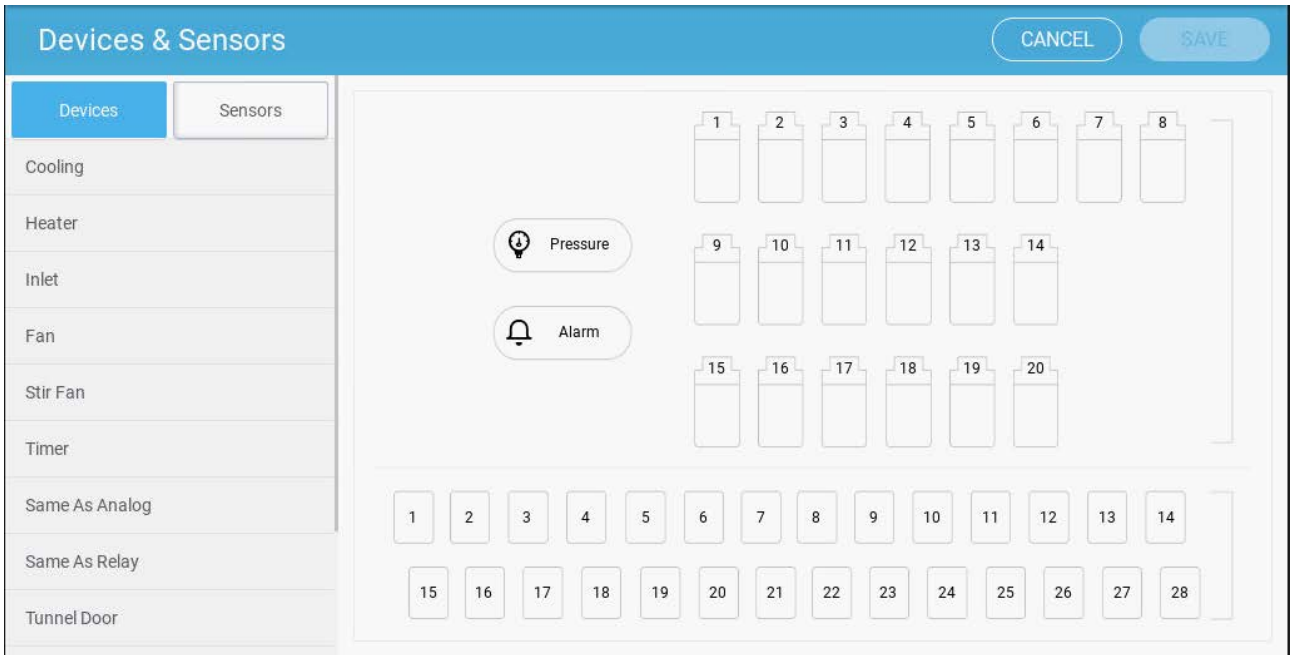

This screen displays the relays and analog/digital ports. At this point all, icons are undefined.

2. Click .



- Click  to map cooling devices, heaters, inlets, fans, stir fans, timers, tunnel doors, outlets, or the alarm relay.
- Click  to map auxiliary inputs, sensors (humidity, pressure, temperature, CO2, ammonia), water meter, and potentiometers.

3. Under Devices or Sensors, click the type of device that you want to map. In the following example, Heater is selected. The screen displays the relays and ports that can be defined as heaters.

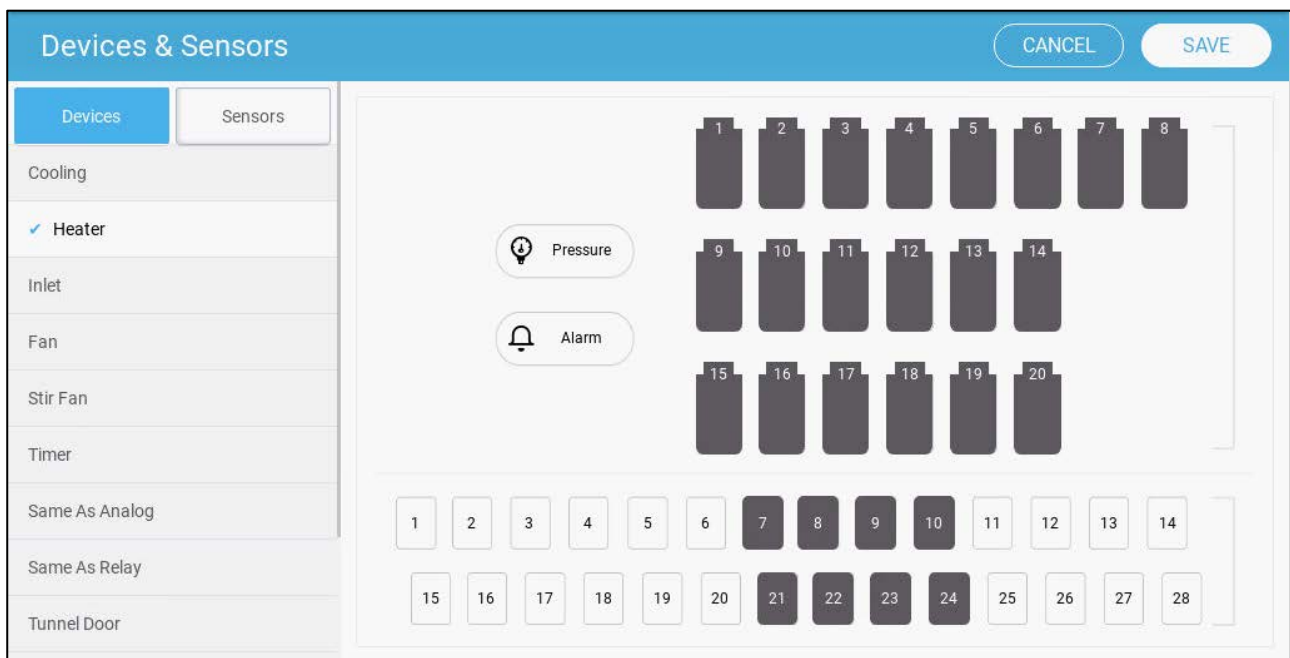

4. Click on the relays and/or ports that you wired to heaters.

- TRIO automatically numbers the devices.
- TRIO enables selecting up to the maximum number of each device.
- Devices having opening and closing relays require mapping of both relays.

5. Repeat steps 3 and 4 for all the connected devices.

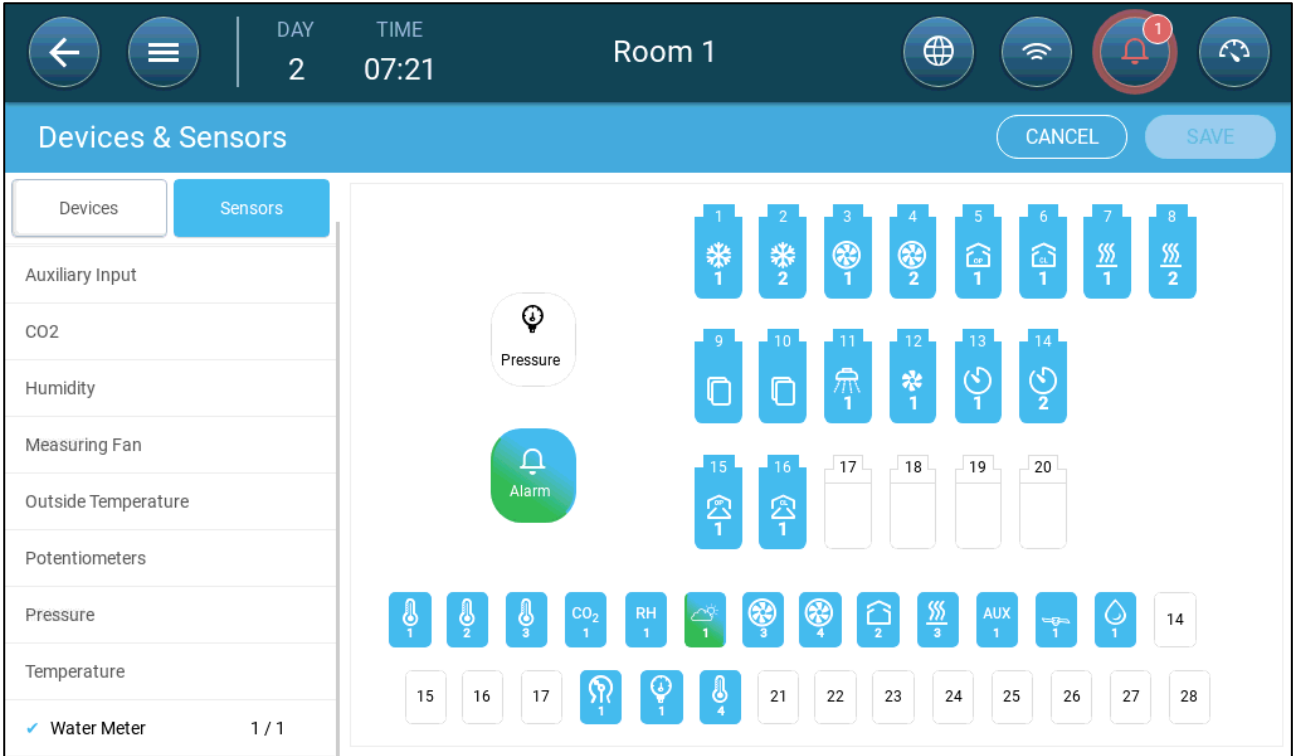

6. After mapping all installed devices, click **SAVE**.

*NOTE To un-map a device, click on the required device and hold the icon down.*

*NOTE If you map a sensor that is not physically connected to the TRIO, an error symbol appears on the designated analog port.*

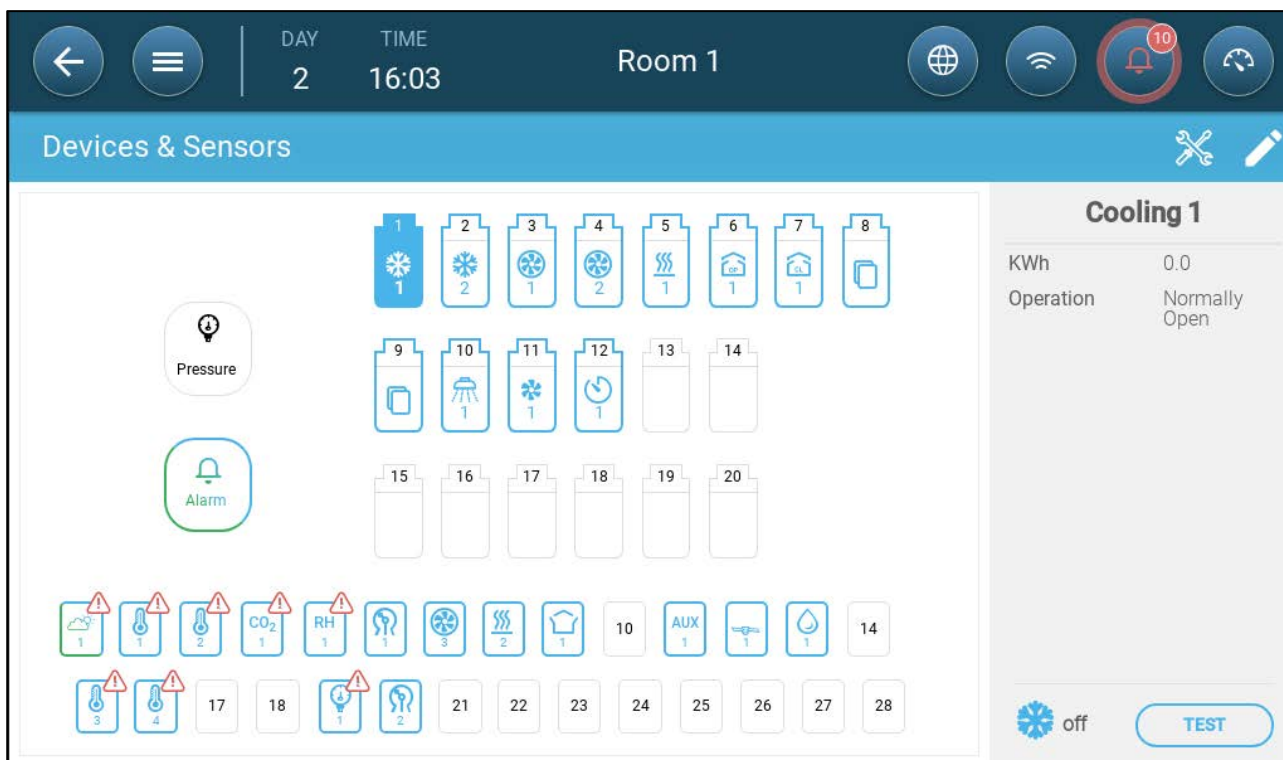

## 7.2 Editing the Relays and Sensors

1. On the Device and Sensors screen, click a relay or sensor.
2. Click .
3. Edit the parameter(s).
4. Click **Save**.

## 7.3 Defining Sensors

- Defining Analog Sensor
- Defining Digital Sensors

### 7.3.1 DEFINING ANALOG SENSOR

- Enabling/Disabling Analog Input Sensors
- Temperature Sensors
- Defining the Ammonia Sensor
- Defining the CO2 Sensor
- Defining the Humidity Sensor

### 7.3.1.1 Enabling/Disabling Analog Input Sensors

By default, when the user maps an analog input sensor, the sensor is enabled. To disable a sensor:

1. Go to the device and click edit .
2. Move the enable mode icon to off and click Save.

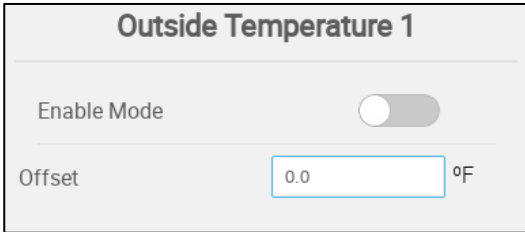

3. On the dashboard, a disabled sensor is marked.

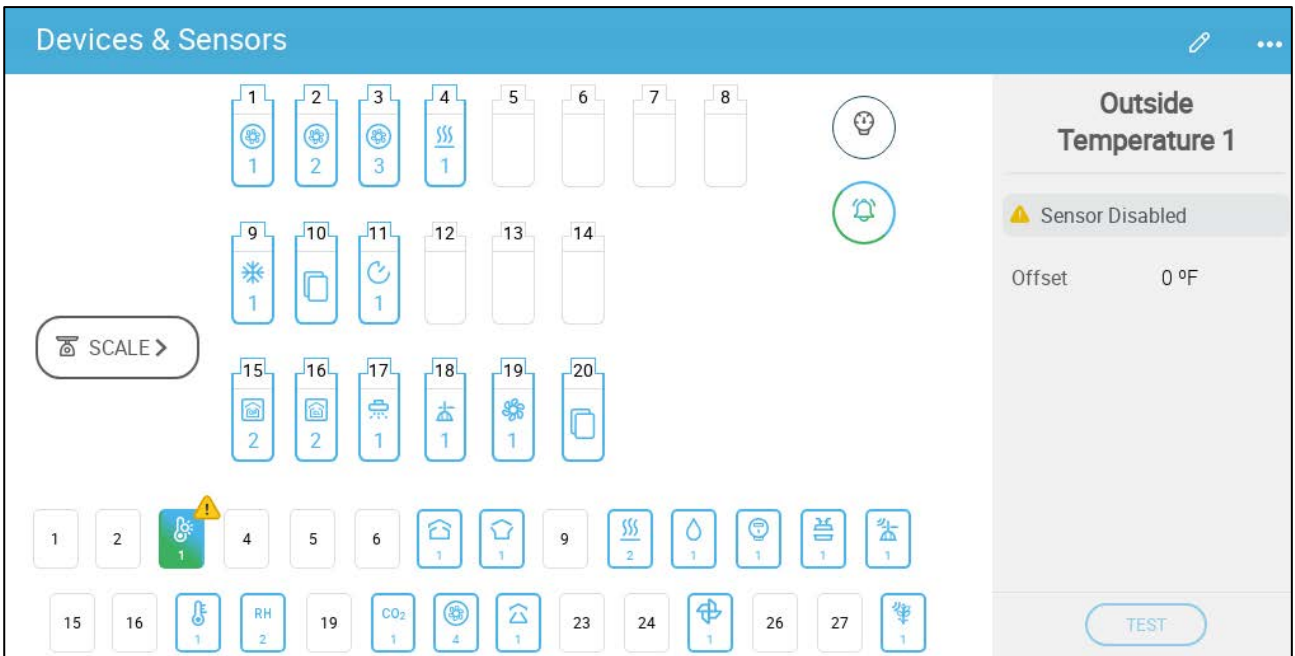

### 7.3.1.2 Temperature Sensors

- Defining the Temperature Sensors
- Mapping the Temperature Sensors
- Enabling a Weather Station

#### 7.3.1.2.1 Defining the Temperature Sensors

- Define up to 12 analog input ports as temperature sensors (and if required one port as an outside temperature sensor) (refer to Using the Mapping , page 65).

Temperature 1	
Offset	0 °F
Location	Front
TEST	

Outside Temperature 1	
Offset	0 °F
TEST	

- Define:
  - Offset: This is an optional correction for the temperature sensor. Range:  $-10^{\circ}$  C to  $+10^{\circ}$  C
  - Location: Designate the area in the room where the sensor is located (front/back/center) or designate the sensor as a Piglet Zone sensor.

#### 7.3.1.2.2 Mapping the Temperature Sensors

Calculating the temperature data, TRIO takes the following into consideration:

**Tunnel temperature:** Select a sensor or a group of sensors to determine the tunnel temperature readings or select if the tunnel runs according to the average temperature reading.

**Average temperature:** Data from multiple sensors can be averaged. If a sensor fails, the sensor's data is removed from any calculations.

**Device temperature:** A sensor (or sensors) can be mapped to a specific device.

**Outside temperature:** The temperature sensor defined as an outside temperature is not included in any average calculation.

Map specific temperature sensors to specific devices.

- Go to System > Temperature Definition.

Device	Avg.	Temperature Sensors			Outside
Average		1	3	4	
Cooling 1			3		
Cooling 2		1			
Timer 1				4	
Timer 2					✓
Timer 3		1			

- Map the sensors to devices.
  - Define which sensors are used to calculate the average temperature.
  - If an outside temperature sensor is enabled, map timers to it (if required).

*NOTE Uninstalling a device in the Relay Layout, Analog Output or TRIAC tables removes the device from this screen.*

### 7.3.1.2.3 Enabling a Weather Station

To save costs on temperature sensors, one outdoor temperature sensor can provide data to the entire TRIO network.

1. In System > Device and Sensors, define one sensor as Outside Temperature.
2. Go to System > Control Strategy > Weather Station .

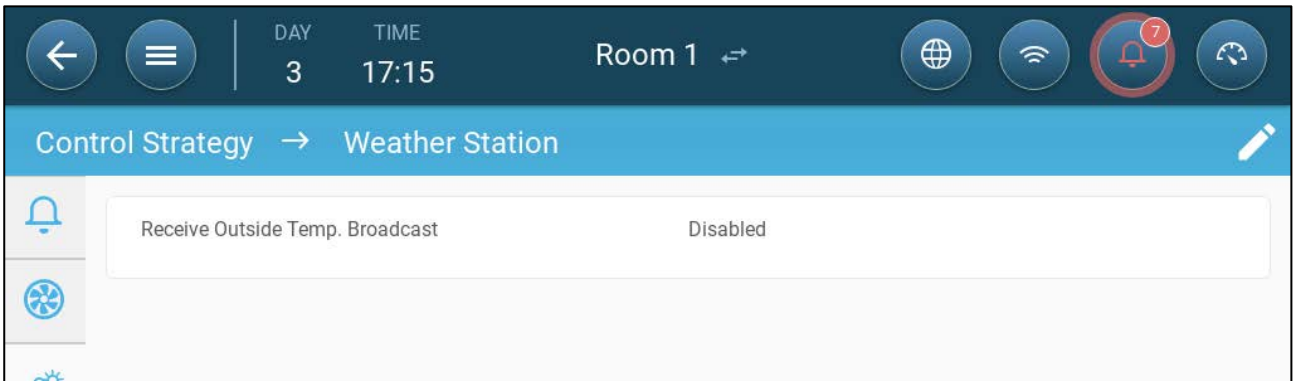

3. Enable Receive Outside Temp. Broadcast.

### 7.3.1.3 Defining the Ammonia Sensor

➡ Define one analog input port as an ammonia sensor (refer to Using the Mapping , page 65).



- Define:
  - Offset: This is an optional correction for the ammonia sensor. Range: -10 to +10 ppm

### 7.3.1.4 Defining the CO2 Sensor

➡ Define one analog input port as a CO2 port (refer to Using the Mapping , page 65)).

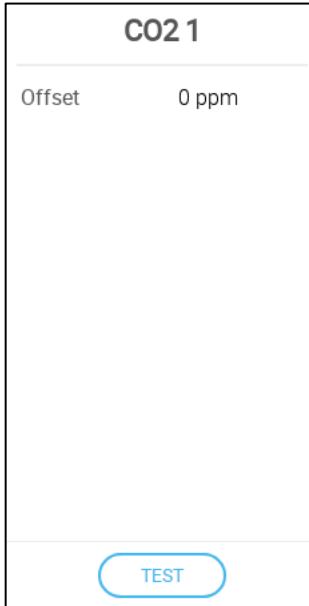

- Define:
  - Offset: This is an optional correction for the CO2 sensor. Range: -500 to +500 ppm

### 7.3.1.5 Defining the Humidity Sensor

- Define (refer to Using the Mapping Screen, page 65).
  - One or two analog input ports as a humidity sensor
  - One analog input port as an outside humidity sensor

Humidity 2

Offset 0

TEST

Outside Humidity 1

Offset 0

TEST

- Define: Offset: This is an optional correction for the humidity sensor. Range: -10 to +10%

### 7.3.2 DEFINING DIGITAL SENSORS

- Defining the Water Meter Sensors
- Defining the Gas Meter Sensors
- Defining the Power Meter Sensors
- Defining the Feeder Active Sensor
- Defining the Feeder Line Sensor
- Defining the Auxiliary Input
- Defining the Measuring Fan

### 7.3.2.1 Defining the Water Meter Sensors

➡ Define up to four digital input ports as a water meter (refer to Using the Mapping , page 65).

Water Meter 1	
QTY/Pulse	0.3 G
Meter Input	Drinking Water

TEST

- Define:
  - Quan/Pulse: Set the water meter’s water flow per pulse. Range: 0.0 to 99.9 (unit depends on the General Settings > User).
  - Meter input: Chose drinking water or cooling.

### 7.3.2.2 Defining the Gas Meter Sensors

➡ Define up to three digital input ports as a gas meter (refer to Using the Mapping , page 65).

Gas Meter 1	
QTY/Pulse	0.3 G

TEST

- Define: Quan/Pulse: Set the gas meter’s flow per pulse. Range: 0.0 to 999 (unit depends on General Settings > User).

### 7.3.2.3 Defining the Power Meter Sensors

➡ Define up to two digital input ports as a power meter (refer to Using the Mapping , page 65).

Power Meter 1	
Power Source	Main
Pulses per kW	1

- Define:
  - Power Source:
    - Main: Power meter measures the amount of electricity used by the system.
    - Heat: Power meter measures the amount of electricity used by the heaters.
  - Pulses kW: Set the number of pulses per kilowatt. Range: 1 to 1000.

### 7.3.2.4 Defining the Feeder Active Sensor

➡ Define one digital input port as feeder active (refer to Using the Mapping , page 65).

Feeder Active 1	
Active State	Open

- Define: Active State: Select if the relay is normally open or normally close.
  - Open: The circuit is open when the sensor is activated.
  - Closed: The circuit is closed when the sensor is activated.

### 7.3.2.5 Defining the Feeder Line Sensor

➡ Define one digital input port as feeder line (refer to Using the Mapping , page 65).

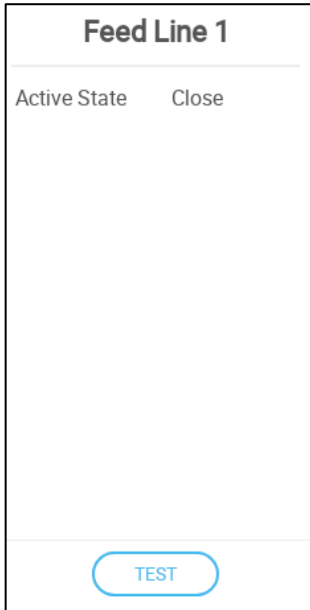

- Define: Active State: Select if the port is normally open or normally closed.
  - Open: The circuit is open when the sensor is activated.
  - Closed: The circuit is closed when the sensor is activated.

### 7.3.2.6 Defining the Auxiliary Input

➡ Define up to four digital inputs as auxiliary inputs (refer to Using the Mapping , page 65).

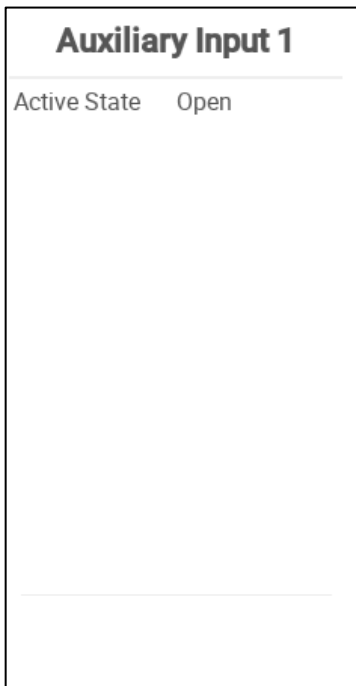

- Define: Active State:
  - Open: The circuit is open when the sensor is activated.
  - Closed: The circuit is closed when the sensor is activated.

### 7.3.2.7 Defining the Measuring Fan

- Define one digital input sensor as a measuring fan (refer to Using the Mapping , page 65).

Measuring Fan 1	
Brand	Reventa
Inner	370
Related Fan	None
<input type="button" value="TEST"/>	

- Define:
  - Brand: Select the fan manufacturer.
  - Inner: Select the fan circumference.
  - Related Fan: If the measuring fan is to be used for compensation, define the fan to be used to provide the extra air. Refer to Ventilation Compensation in the User Manual.

*NOTE A relay or port must be defined as a fan for this parameter to be enabled.*

## 7.4 Defining Devices

- 0 – 10 Volt Analog Output Devices
- Defining the Fans
- Defining the Stir Fan
- Defining the Blowback Fan
- Defining Heating Devices
- Defining the Cooling Devices
- Defining the Foggers
- Mapping the Potentiometers, Inlets, Tunnel Doors, Outlets
- Defining the Sprinkler
- Defining the Same As Relays
- Defining the Same As Analog Ports
- Defining the Timers
- Defining the Feeder Relay
- Defining Fail Safe Devices

### 7.4.1 0 – 10 VOLT ANALOG OUTPUT DEVICES

Several devices can be controlled by relays or analog output ports. In analog output-controlled devices, the user defines the voltages that define the devices' minimum and maximum output. For example, if the minimum voltage is set to 2V and the maximum to 8V the controller applies the calculated 0-100% output over a 2V-8V signal.

### 7.4.2 DEFINING THE FANS

The following sections detail how to configure fans.

*NOTE These settings should be configured by a technician familiar with the fan and inlet/curtain specifications.*

Fan air capacity defines how much air is provided when the fans run at full speed. These numbers are used to calculate minimum air requirements.

- In General Settings > User define the measurement unit.
- Define up to 20 relays or analog output ports as On/Off or 0 – 10 V fans, respectively (refer to Using the Mapping , page 65)).
  - On-Off Fans
  - 0 – 10 Volt Fans

#### 7.4.2.1 On-Off Fans

Fan 1	
Capacity	0 M3/h
KWh	0
Reverse Relay Output	<input type="checkbox"/>

TEST

- Define:
  - Capacity: Enter the fan capacity.
  - KWh: This field displays the amount of kilowatts used. Read-only.
  - Reverse Relay Output: Select if the relay is normally open or normally close.

### 7.4.2.2 0 – 10 Volt Fans

Fan 4	
Min. Voltage (V)	0
Max. Voltage (V)	10
Min. Capacity	0 CFM
Max. Capacity	0 CFM
KWh	0
Boost Time (sec.)	5

- Define:
  - Minimum/Maximum Voltage: Enter the minimal and maximal voltage used to calibrate the fan speed.
  - Minimum/Maximum Capacity: Enter the fan’s minimum and maximum capacity.
  - KWh: This field displays the amount of kilowatts used. Read-only.
  - Boost Time: During this amount of time, the controller applied full power to the fan motor (100%). Boosting the speed is done to open shutters or extend the motor life. In addition, some types of motors have a minimum starting speed.

### 7.4.3 DEFINING THE STIR FAN

- Define up to five relays or analog ports as a stir fan (refer to Using the Mapping , page 65)).
  - On Off Stir Fan
  - 0 – 10 Volt Stir Fan

#### 7.4.3.1 On Off Stir Fan

Stir Fan 1	
KWh	0
Reverse Relay Output	<input type="checkbox"/>

- Define:
  - KWh: This field displays the amount of kilowatts used. Read-only
  - Reverse Relay Output: Select if the relay is normally open or normally close.

### 7.4.3.2 0 – 10 Volt Stir Fan

Stir Fan 1	
Min. Voltage (V)	0
Max. Voltage (V)	10
KWh	0

TEST

- Define:
  - Minimum/Maximum Voltage: Enter the minimal and maximal voltage used to calibrate the fan speed.
  - KWh: This field displays the amount of kilowatts used. Read-only.

### 7.4.4 DEFINING THE BLOWBACK FAN

➡ Define one relay as a blowback fan.

Blowback Fan 1	
KWh	0
Reverse Relay Output	<input type="checkbox"/>

TEST

- Define:
  - KWh: This field displays the amount of kilowatts used. Read-only
  - Reverse Relay Output: Select if the relay is normally open or normally close.

### 7.4.5 DEFINING HEATING DEVICES

- Define up to six relays or analog output ports as heaters (Using the Mapping , page 65).
  - Defining the On/Off Heaters
  - Defining the Variable Heaters
  - Defining the High Heaters

#### 7.4.5.1 Defining the On/Off Heaters

Heater 1	
KWh	0
Operation	Normally Open
Ignition Time (sec.)	0

**TEST**

- Define:
  - KWh: This field displays the amount of kilowatts used. Read-only
  - Reverse Relay Output: Enable this function for Normally Closed Relays.
  - Ignition Time (sec.): Define the delay time between when the heater is turned on and when the gas is ignited.

#### 7.4.5.2 Defining the Variable Heaters

Heater 2	
Min. Voltage (V)	0
Max. Voltage (V)	10
KWh	0

**TEST**

- Define:
  - Min./Max Voltage: Define the voltage in the analog output port that corresponds to the 0% and 100% output, respectively.
  - KWh: This field displays the amount of kilowatts used. Read-only.

### 7.4.5.3 Defining the High Heaters

High heaters work in conjunction with relay heaters. High heater 1 works with heater 1, high heater 3 works with heater 3, and so on. If there is no corresponding heater to a high heater, the latter does not function. For example, if there are three heaters and four high heaters, high heater 4 does not function.

➡ Define up to six relays as high heaters.



- Define:
  - Reverse Relay Output: Enable this function for Normally Closed Relays.

### 7.4.6 DEFINING THE COOLING DEVICES

➡ Define up to two relays as cooling devices (refer to Using the Mapping , page 65).

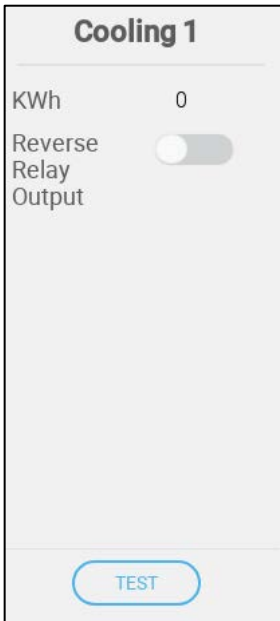

- Define:
  - KWh: This field displays the amount of kilowatts used. Read-only.
  - Reverse Relay Output: Enable this function for Normally Closed Relays.

### 7.4.7 DEFINING THE FOGGERS

➡ Define up to six relays as foggers.

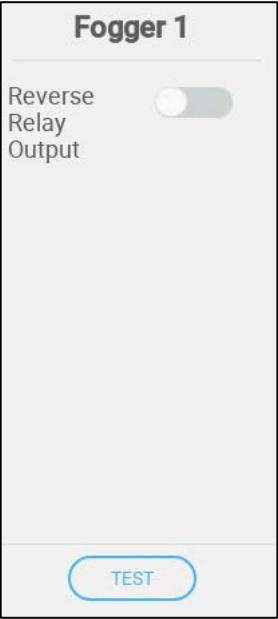

- Define: Reverse Relay Output: Enable this function for Normally Closed Relays.

## 7.4.8 MAPPING THE POTENTIOMETERS, INLETS, TUNNEL DOORS, OUTLETS

- Mapping the Potentiometers
- Defining the Inlets/Tunnel Doors
- Defining the Outlet

### 7.4.8.1 Mapping the Potentiometers

➡ Define up to four analog ports as potentiometers.

As an option, potentiometers enable exact positioning of relay-controlled inlets\tunnel doors when calibrating. If:

- potentiometers are not employed or
- there is a potentiometer failure

opening and closing times are used to calibrate the inlets/tunnel doors.

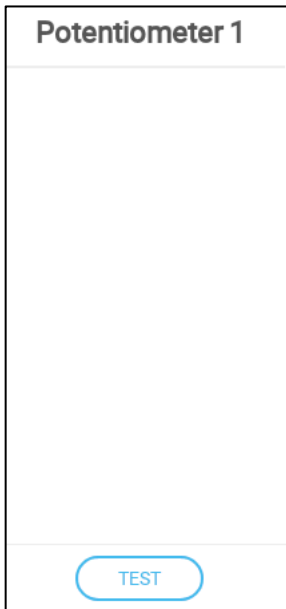

- Enable/disable the potentiometer.

### 7.4.8.2 Defining the Inlets/Tunnel Doors

- Define up to four relays or analog output ports as inlets or tunnel doors (each device requires two relays or one analog port) (refer to Using the Mapping , page 65).

Inlet 2	
Position	By Time
Open Time (sec.)	60
Close Time (sec.)	60
Open Reverse Relay Output	<input type="checkbox"/>
Close Reverse Relay Output	<input type="checkbox"/>
<input type="button" value="TEST"/>	

Tunnel Door 1	
Min. Voltage (V)	0
Max. Voltage (V)	10
Open Time (sec.)	60
Close Time (sec.)	60
<input type="button" value="TEST"/>	

- For relay-controllers devices, define:
  - Position: Define how the inlet opening is controlled:
    - By time
    - Potentiometer (relay-controlled inlets or tunnel doors only). Map each inlet/tunnel door to a potentiometer. This option appears only if potentiometers are mapped.
  - Open/Close Time: Measure and enter the amount of time required to fully open or fully close the inlet. These parameters are only enabled when Position/By Time is selected.
  - Open/Close Reverse Relay Output: Enable this function for Normally Closed Relays.
  - Calibrate: Manually calibrate inlets/tunnel doors positioned by a potentiometer. Potentiometer-controlled calibration only.
- For 0 – 10V controlled devices, define:
  - Min./Max Voltage: Define the voltage in the analog output port that corresponds to the 0% and 100% output, respectively.
  - Open/Close Time: Measure and enter the amount of time required to fully open or fully close the inlet.

#### 7.4.8.2.1 Potentiometer Calibration

If used, a potentiometer can control the opening and closing with a high degree of precision. When there is no potentiometer, positioning accuracy tends to degrade after the inlets go through several opening and closing cycles.

In order to calibrate the inlets/vents using a potentiometer:

- Install and map at least one potentiometer.

- Define the position as By Potentiometer.
- Click Calibrate. Calibration must be successful.

In for any reason potentiometer calibration does not function:

- calibration is by time (auto and/or at power up). Time calibration does not fail.
- A potentiometer alarm is generated (if alarms are enabled) . The alarm must be reset to enable potentiometer calibration to function.

#### 7.4.8.2.2 Calibrating the Inlets/Tunnel Door

During installation, the user enables auto-calibration or power up calibration in digital output (relay) inlets. Calibration automatically takes place after the number of inlet movements equals the number of movements required to start calibration or at Trio power up.

Only one inlet or tunnel curtain can be calibrated at a time.

- Relay open occurs when the target position is 100%.
- Relay close occurs when the target position is 0%.

1. Go to System > Control Strategy > Ventilation .

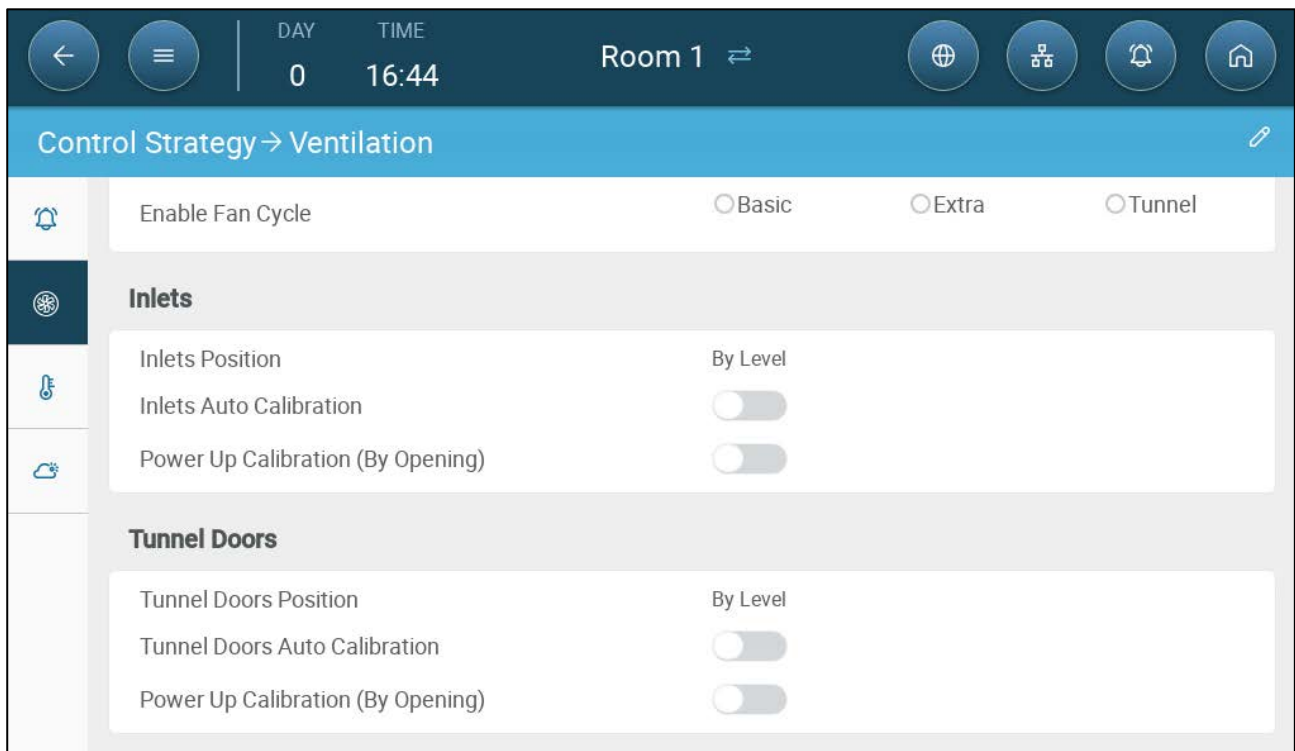

2. Define:

- Inlets/Tunnel Position: Refer to the User Manual.
- Auto Calibration: If enabled, the inlet or tunnel automatically recalibrates itself.
  - Select 24 hours a day or define a specific time frame.
  - Number of Movements: Define the number of steps (number of movements) after which the inlet/tunnel door automatically calibrates.
- Power Up Calibration: Enable this function to have the inlet/tunnel recalibrate itself each time power is applied.

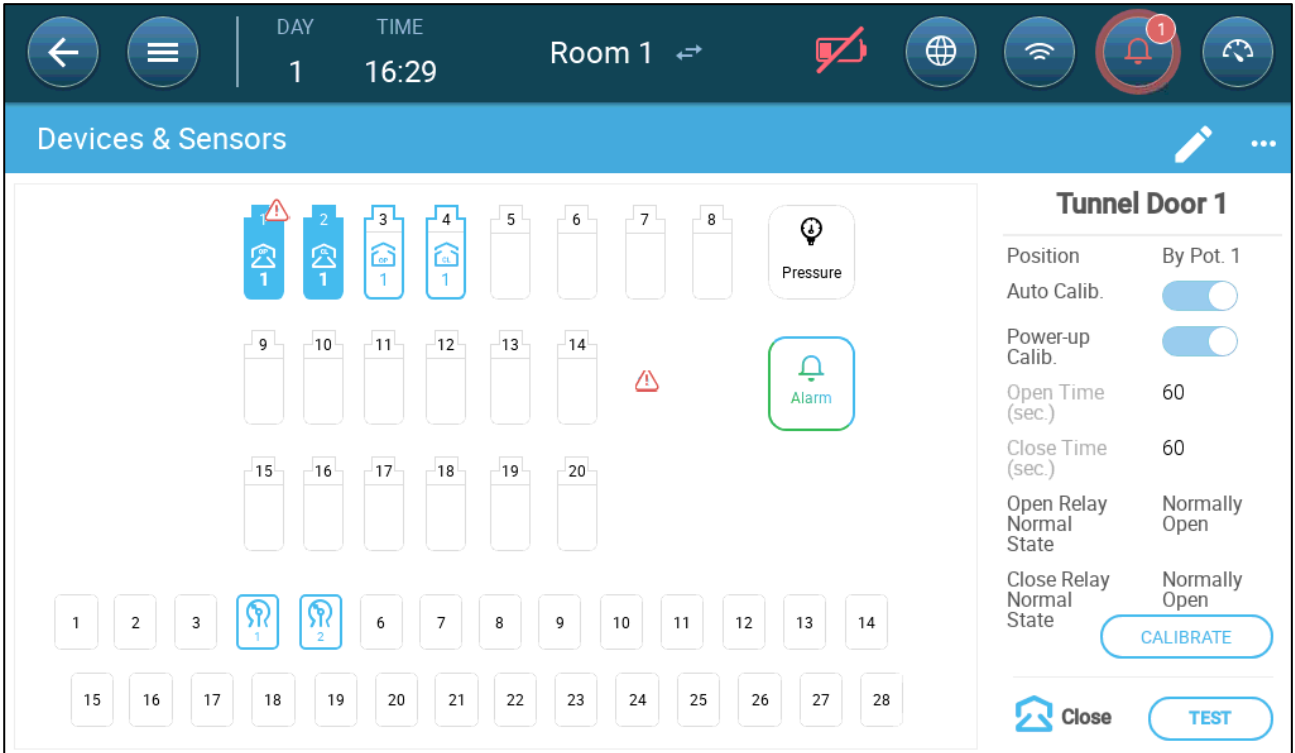

In this situation, click **Calibrate** to run the Calibration Wizard. If the calibration fails again, check:

- Potentiometer wiring
- Potentiometer
- Inlets' and curtains' opening and closing position. There must be a minimum distance between the two, equivalent to 300 A2D points.

### 7.4.8.3 Defining the Outlet

➡ Define one analog output port as an outlet (refer to Using the Mapping , page 65).

Outlet 1	
Min. Voltage (V)	0
Max. Voltage (V)	10
Open Time (sec.)	60
Close Time (sec.)	60

**TEST**

- Define:
  - **Min./Max Voltage:** Define the voltage in the analog output port that corresponds to the 0% and 100% output, respectively.
  - **Open/Close Time:** Enter the amount of time required to fully open or fully close the outlet.

### 7.4.9 DEFINING THE SPRINKLER

➡ Define one relay as a sprinkler (refer to Using the Mapping , page 65).

Sprinkler 1	
KWh	0
Operation	Normally Open

- Define:
  - KWh: This field displays the amount of kilowatts used. Read-only.
  - Operation: Define the relay mode.

### 7.4.10 DEFINING THE SAME AS RELAYS

➡ Define up to 20 relays as Same as Relay (refer to Using the Mapping , page 65).

This function enables defining a relay to operate using the parameters defined for another relay. A relay can be tied to any other relay.

Same As Relay -	
Related Channel	0
KWh	0
Operation	Normally Open

- Define:
  - Related Channel: Define which relay number to follow. Range: 1 – 20
  - KWh: This field displays the amount of kilowatts used. Read-only.
  - Operation: Define the relay mode.

### 7.4.11 DEFINING THE SAME AS ANALOG PORTS

- Define up to eight relays as Same as Analog Ports (refer to Using the Mapping , page 65).

This function enables defining a relay to operate using the parameters defined for a corresponding analog port. Relays can be mapped to eight specific ports only.

**Same As Analog –**

Related Channel	None
KWh	0
Operation	Normally Open

TEST

- Define:
  - Related Channel: Define which port number to follow.
  - KWh: This field displays the amount of kilowatts used. Read-only.
  - Operation: Define the relay mode.

Port Number	Related Channel
7	1
8	2
9	3
10	4
21	5
22	6
23	7
24	8

### 7.4.12 DEFINING THE TIMERS

➡ Define up to five relays as timers (refer to Using the Mapping , page 65).

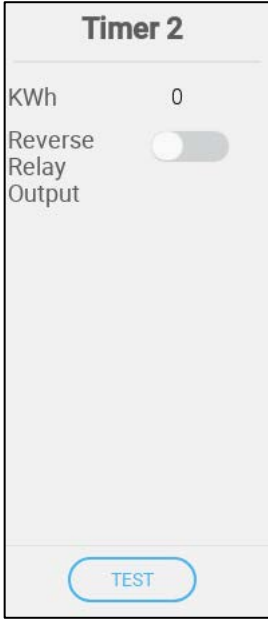

- Define:
  - KWh: This field displays the amount of kilowatts used. Read-only.
  - Operation: Define the relay mode.

### 7.4.13 DEFINING THE FEEDER RELAY

➡ Define one relay as feeder (refer to Using the Mapping , page 65).

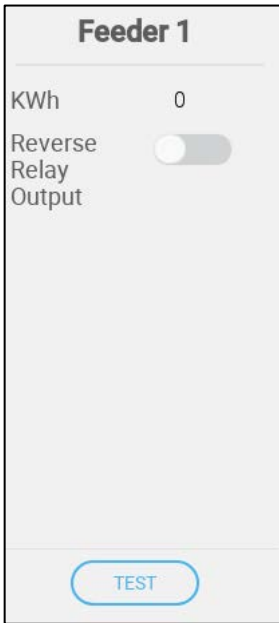

- Define:
  - KWh: This field displays the amount of kilowatts used. Read-only.
  - Reverse Relay Output: Select if the relay is normally open or normally close.

### 7.4.14 DEFINING FAIL SAFE DEVICES

The Failsafe function defines extreme conditions that activate dedicated failsafe relays. These relays activate external devices used to deal with the condition.

➡ Define up to four relays as failsafe relays.

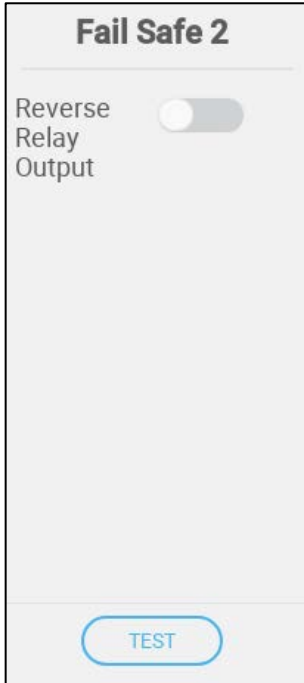

- Define:
  - Reverse Relay Output: Define the relay mode as Closed.

## 7.5 Mapping the Weighing Devices

- Defining the Silos
- Defining the RSU

### 7.5.1 DEFINING THE SILOS

- Mapping the Silo Scales
- Configuring the Silo Scale
- Testing the Silo

#### 7.5.1.1 Mapping the Silo Scales

Trio can support up to four silo scales.

➔ This function requires a scale card.

1. On the Devices & Sensors > Sensors screen, click Silo. The Scale icon turns brown.



2. Click the Scale icon.

3. Select up to four channels and click Save.

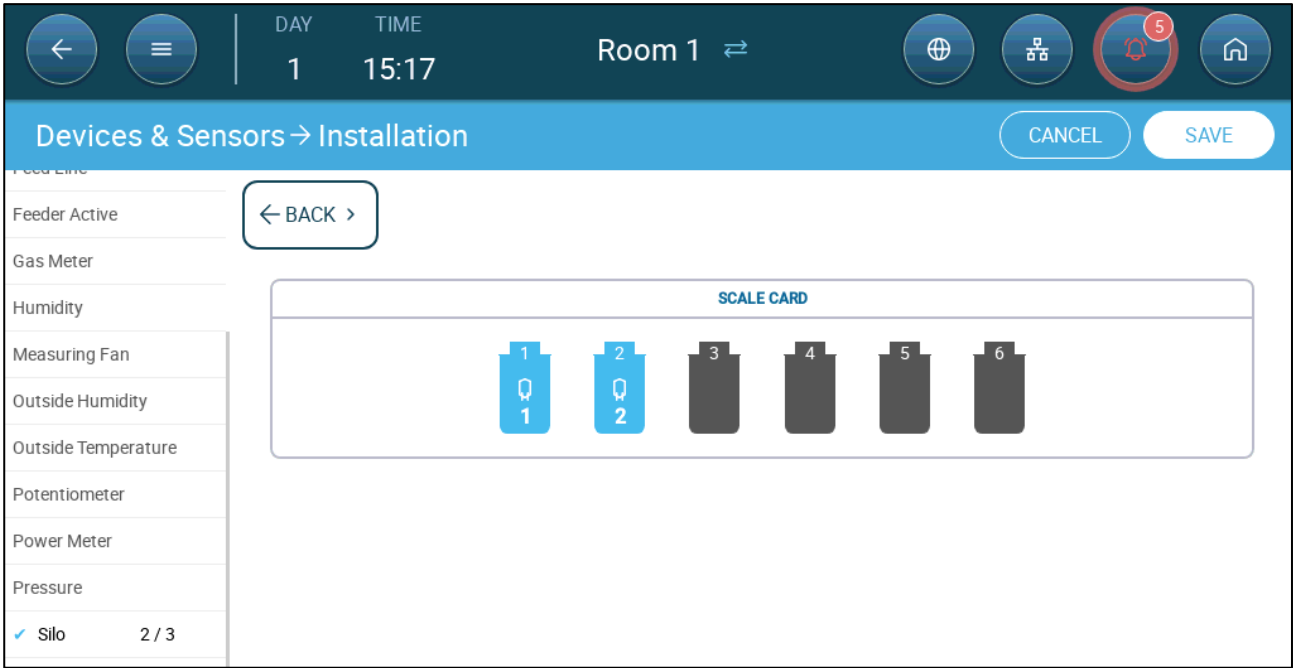

4. Click on each channel.

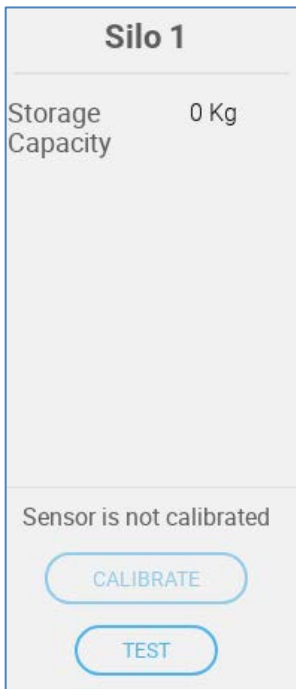

5. Define:

- Enable Mode: Enable/disable the channel.
- Storage Capacity: Define the quantity of feed that each silo can contain.
- Calibrate: Refer to the next section.

### 7.5.1.2 Configuring the Silo Scale

The following procedure details how to “zero out” the Trio silo scales. Zeroing out is way to ensure that the unit’s A2D number is accurate (shown in the Silo Icon; 430 in the picture below). To summarize the procedure:

- The user enters the correct amount of feed in the silo while calibrating the silo scale. In the Silo management screen, the user enters “0” (zero). Trio then defines the current A2D signal to be the A2D signal for an empty bin.

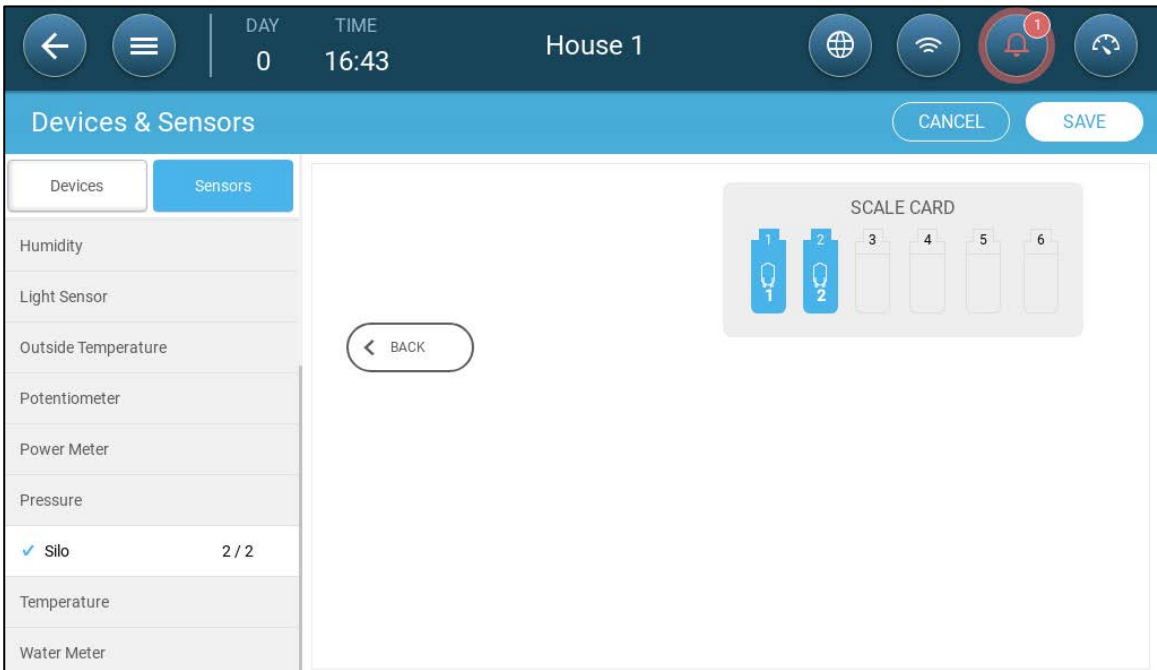

1. Define each silo's storage capacity.
2. Click on the silo icon and click **Calibrate**. The following screen appears:

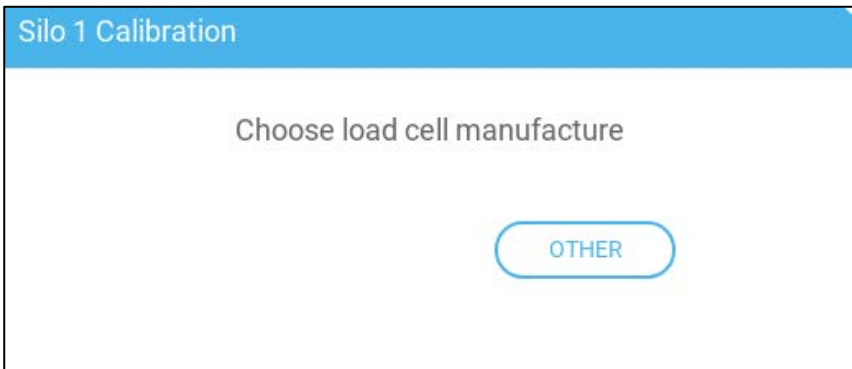

3. Click **Other**. The following screen appears:

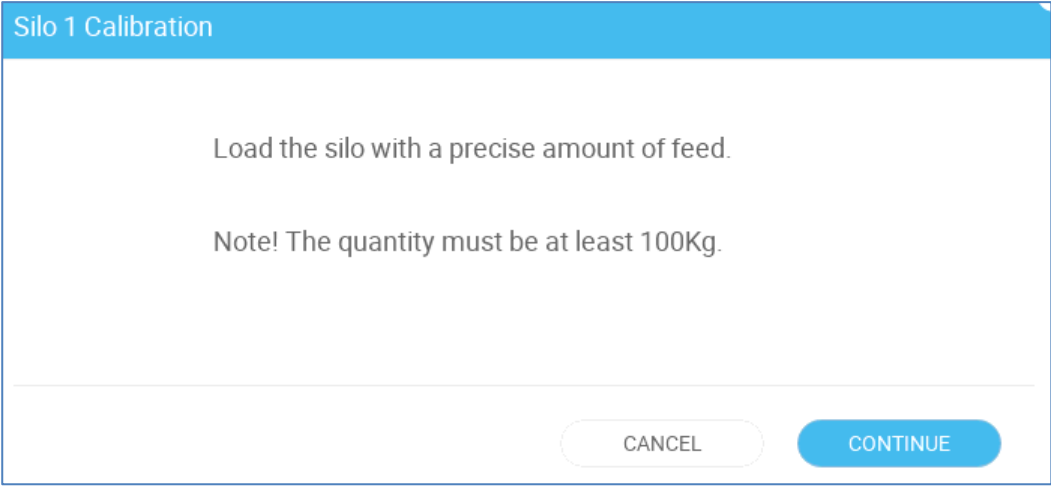

4. Fill up the silo with a known amount of feed. Munters recommends either a truck filling or a minimum of 500 kilograms.

5. Enter the amount of feed in the silo and press Continue.

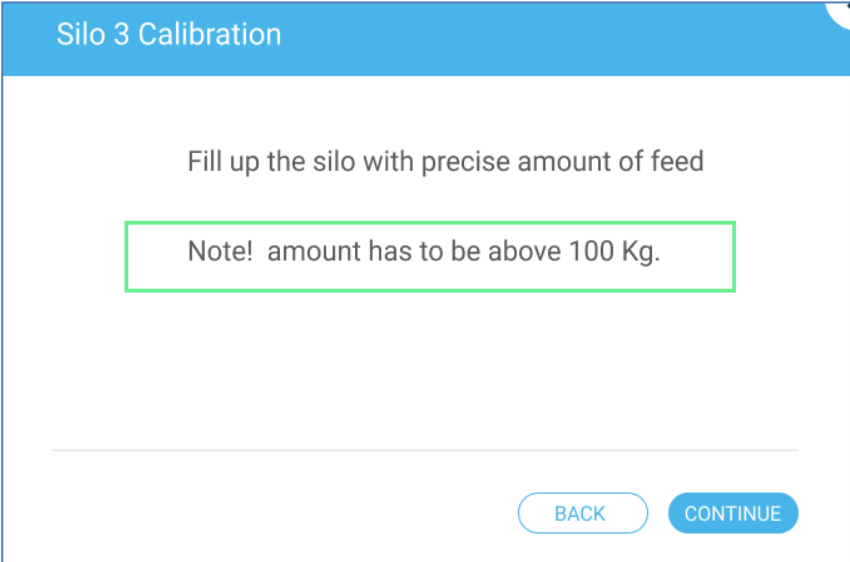

The following screen should appear.

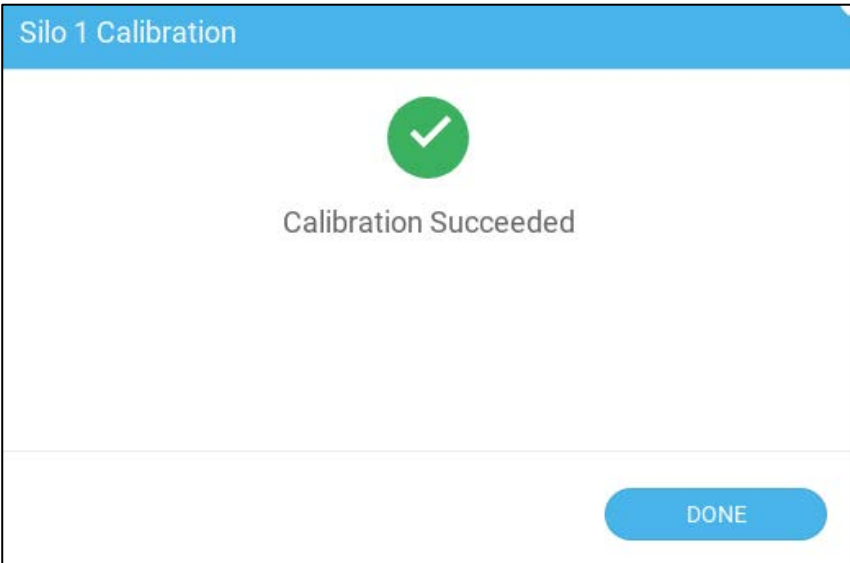

6. Go to Batch > Silo Management.

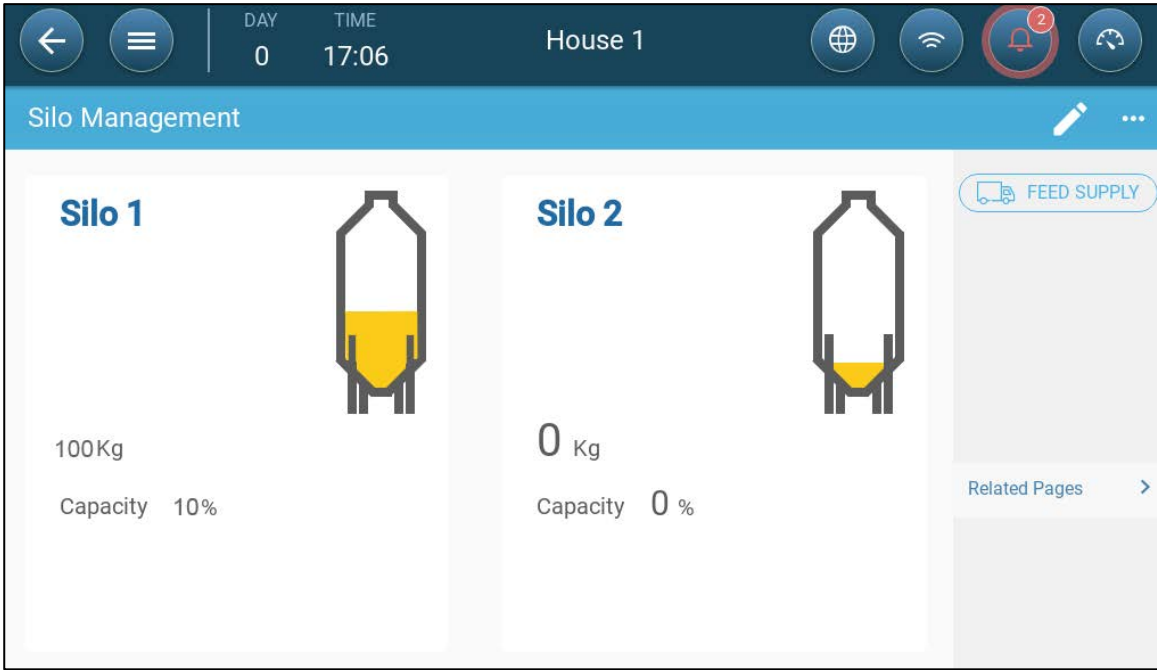

7. Click  and change the feed weight to 0.

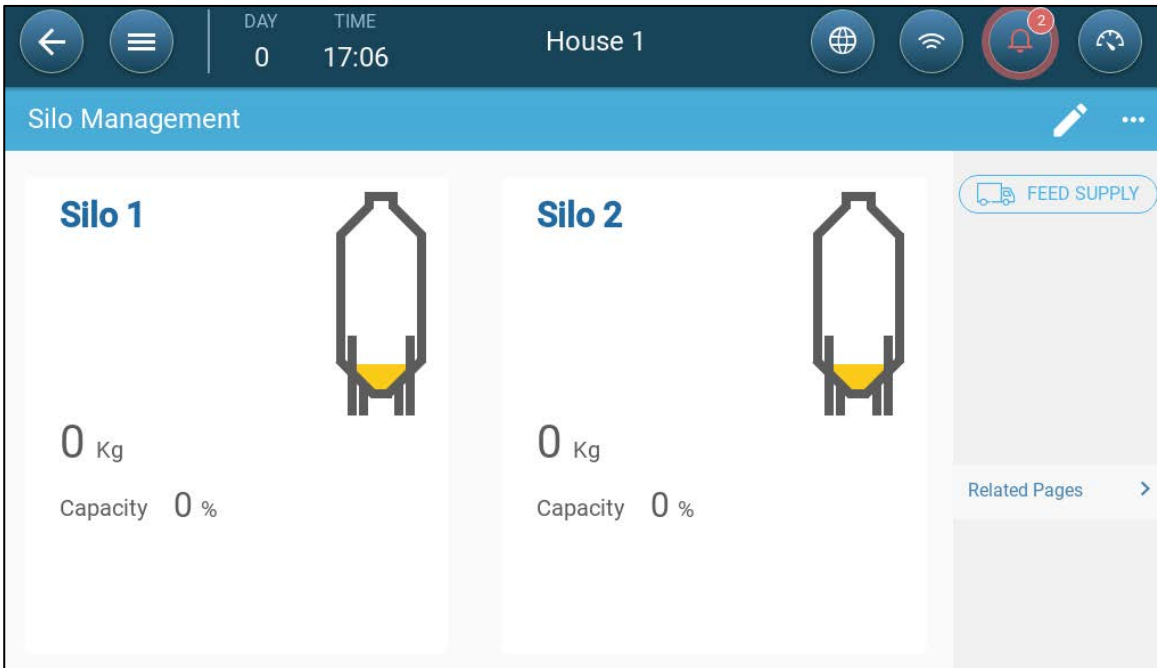

8. Click **Save**.

The Trio now displays an accurate A2D number on the silo icon screen.

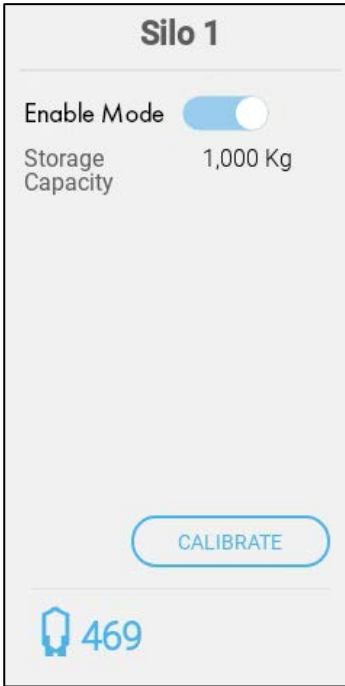

### 7.5.1.3 Testing the Silo

1. After calibrating the silo, go to the Silo relay.



2. Click Test.

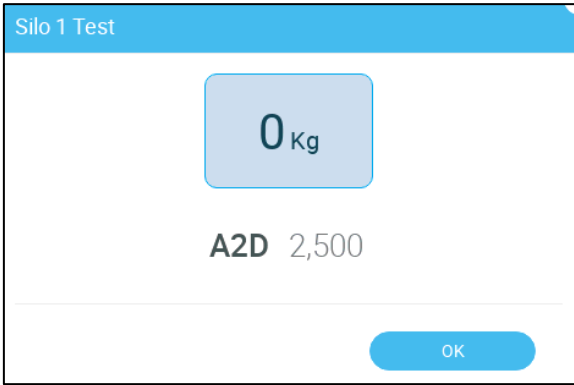

3. Place a known weight in the silo.

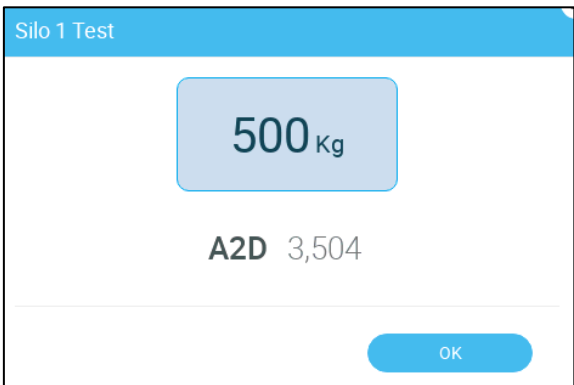

The weight should appear on the screen and the A2D level should rise.

### 7.5.2 DEFINING THE RSU

The following section details how to define up to two RSU units connected to the Trio (optional). For detailed information on using the RSU, refer to the product manual.

➡ Wire the RSU to the Trio as shown in Figure 41, page 51.

1. Reset the Trio, as shown in General Settings > About.
2. Go to Device & Sensors > Installation > Scale.

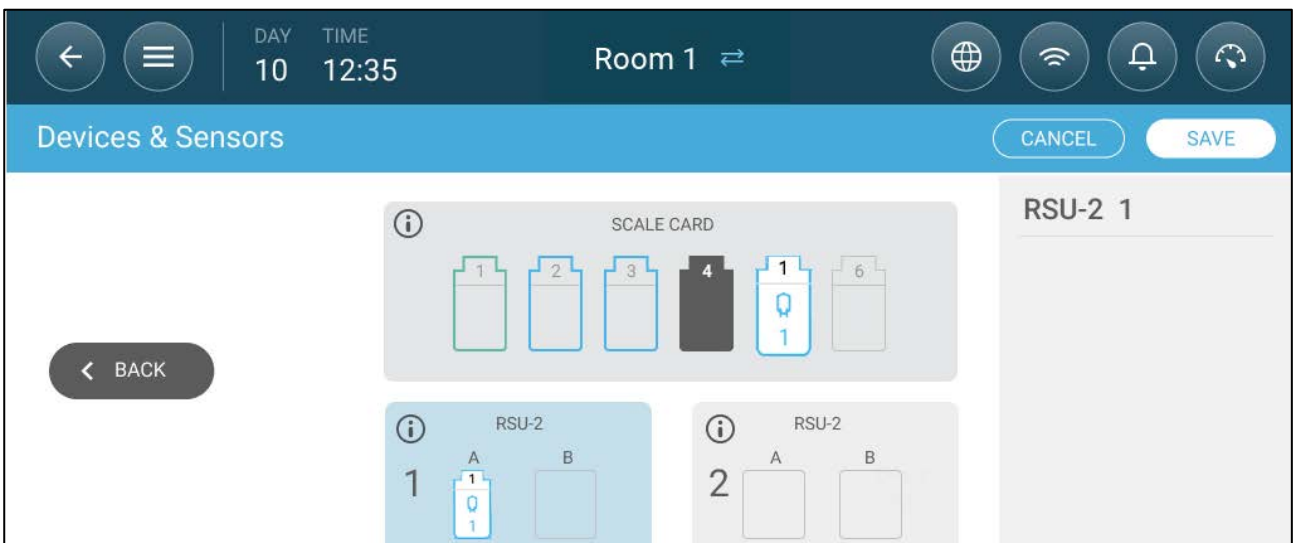

3. Click the RSU icon.
4. Click Calibrate.

Follow the instructions given in Configuring the Silo Scale, page 93.

## 7.6 Trio RPS

- Defining the Sensor
- Static Pressure Calibration

### 7.6.1 DEFINING THE SENSOR

The following section details how to configure the RPS device.

1. Go to System > Devices & Sensors.

2. Click . The Devices & Sensor screen appears.

3. Click .

4. Click **Pressure**.

5. Define an analog input port as the pressure sensor. In the following screen, ports 5 is defined as the pressure sensor.

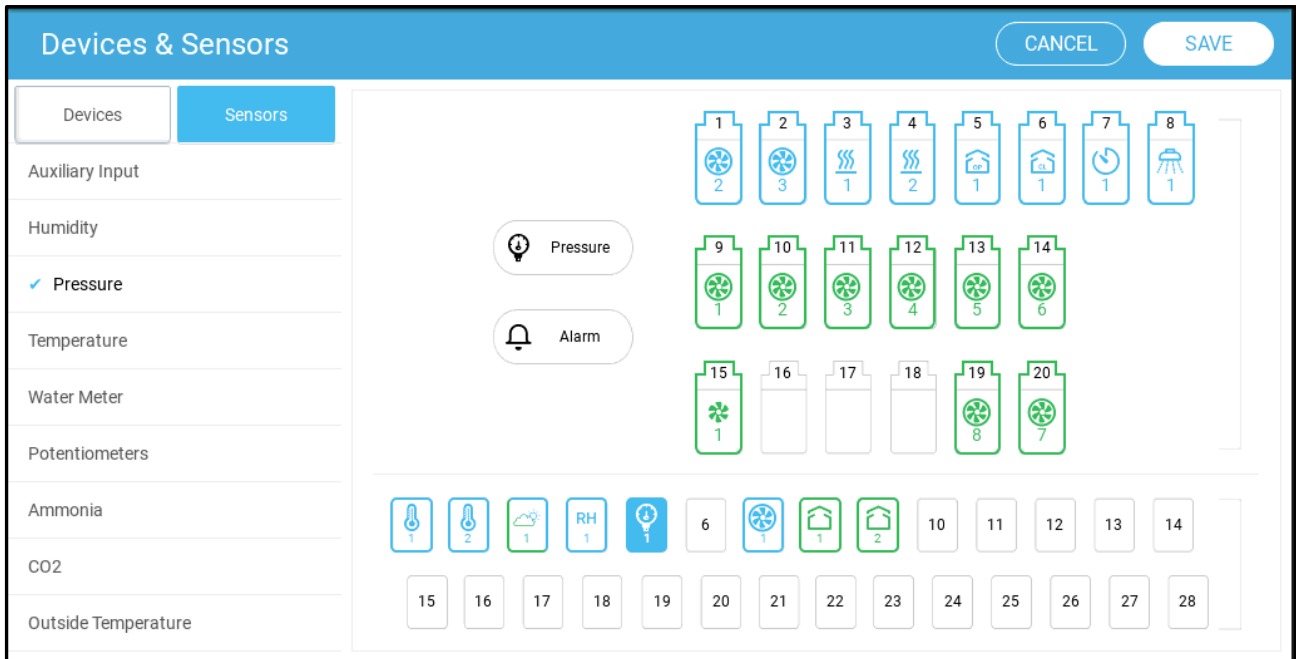

6. Go to Climate > Static Pressure and define the parameters.

### 7.6.2 STATIC PRESSURE CALIBRATION

**CAUTION** The Static Pressure sensor is factory calibrated. Only calibrate the sensor if you have reason to believe that they are producing inaccurate results.

The Static Pressure should be 0 when there is no ventilation and the house is closed. When the controller A/D counts is 100, this means that there is zero (0) static pressure.

**NOTE:** Run the controller for a few hours so that the temperature in the box becomes stable and only then calibrate.

**CAUTION** DO NOT blow the air into the hose to see if the pressure changes! The sensor is sensitive and blowing air can cause irreparable damage.

To calibrate the Static Pressure Sensor:

1. Disconnect the air hoses.
2. Go to *System > Device & Sensors > Pressure*.



3. Click Calibrate.

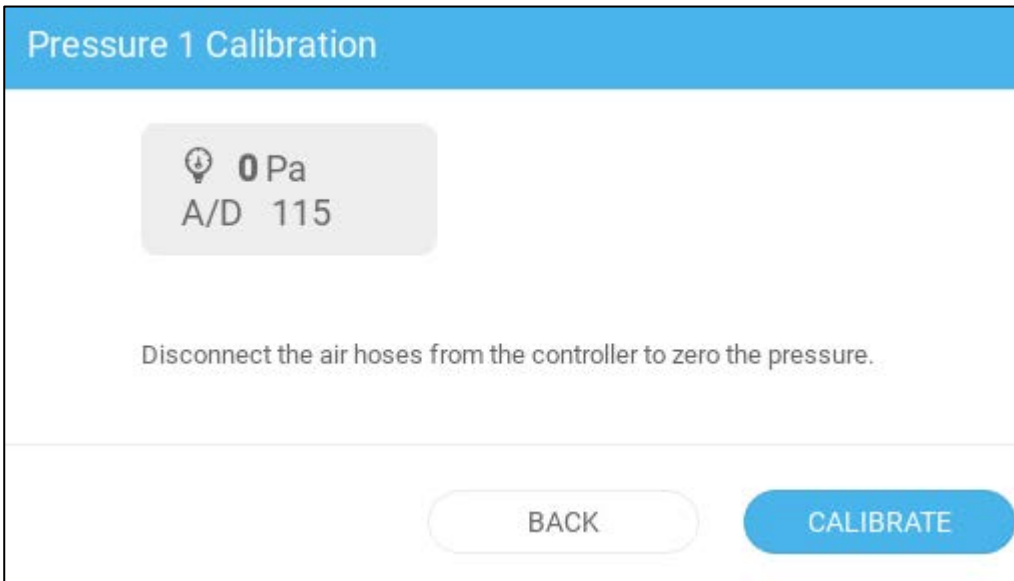

4. If the A/D count is 100 +/- 30 (70 to 130), click **Calibrate**.
5. If the A/D count is less than 70 or greater than 130:
  - a. Check for blocked air hoses or wind interference.
  - b. Open the Trio. On the Main Board, find the Static Pressure Sensor.

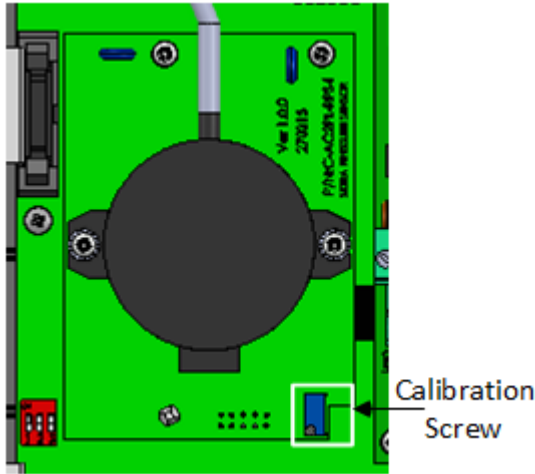

- c. Adjust the zero-pressure reading to approximately 100 by turning the calibration screw.
- d. When the A/D count is within the permitted range, press Calibrate.

### 7.7 Testing Devices

After mapping a device, Trio provides a testing function that enables checking the device's performance.

- Fans: Click Test to test the fan's response. Testing works for fans in Basic, Extra, and Tunnel Mode (Extra/Tunnel Mode: Version 8.3).

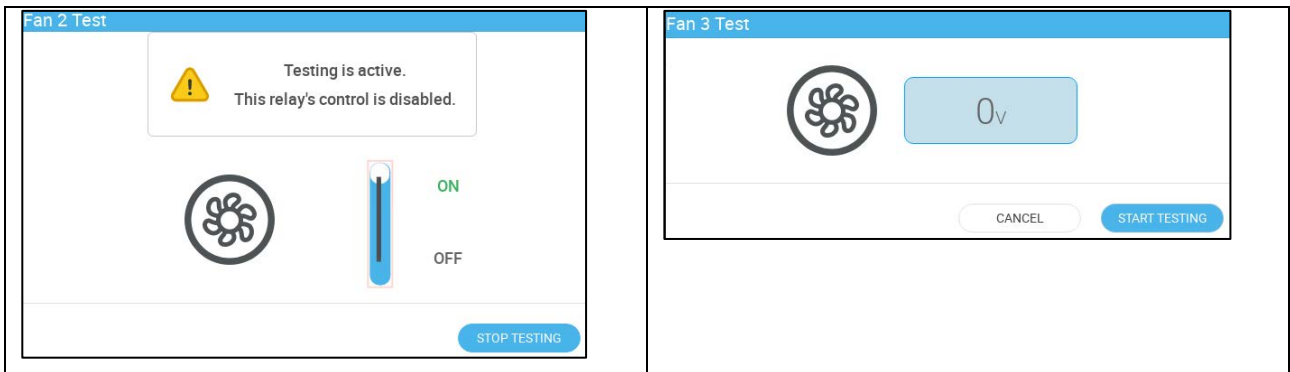

- Relay devices: Click Test > On to ensure that the device turns on.

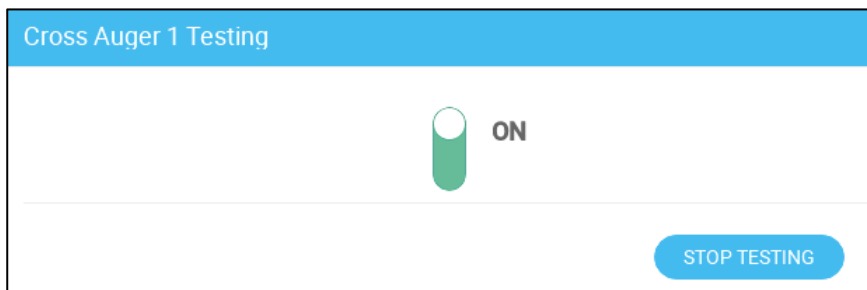

- Analog output devices: Click Test and move the voltage scale to ensure that the device operates at the proper minimum and maximum voltage levels.

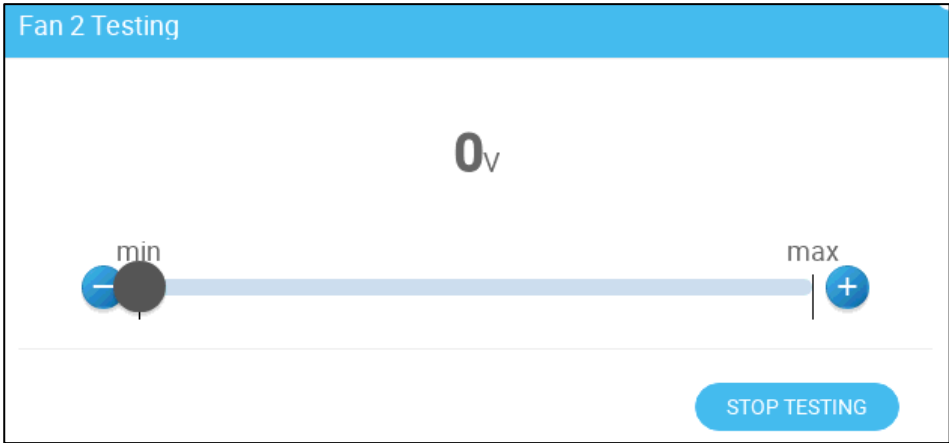

- Analog input devices: Click Test to view the current input results and A2D value. The test function also displays an error message when the input signal is weak or non-existent.

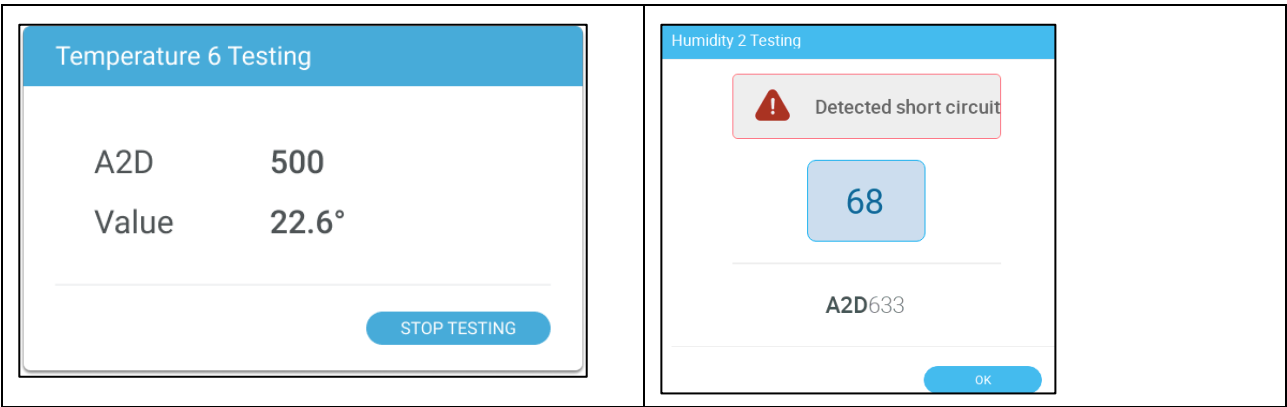

- Acceptable ranges:
  - RTS-2: 200 – 600.
- Digital input devices: Click Test to view the current circuit status (signal close or signal open).

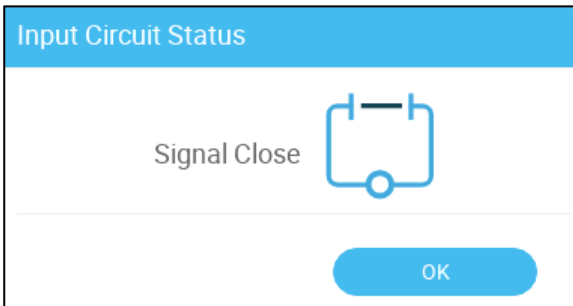

- Potentiometer/Inlets: Before testing the potentiometer:
  - Wire the potentiometer (refer to Potentiometer Device Wiring, page 44)
  - Define an inlet controlled by a potentiometer (refer to Mapping the Potentiometers, page 84).
  - Test the potentiometer:
    1. Using a voltmeter, test the signal voltage between the COM port and selected S port (S2 in Figure 45).

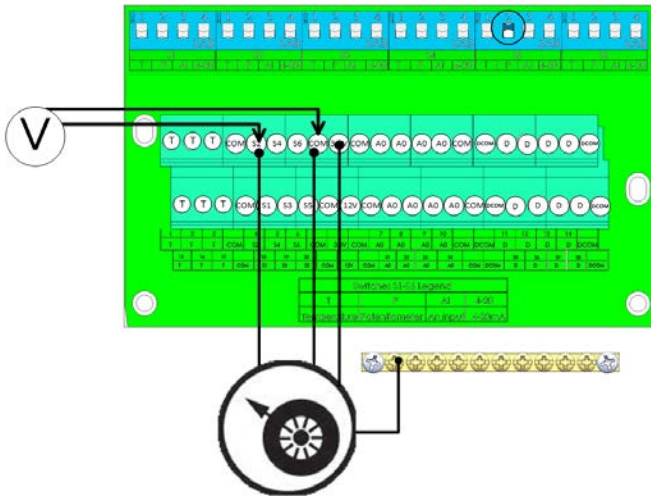
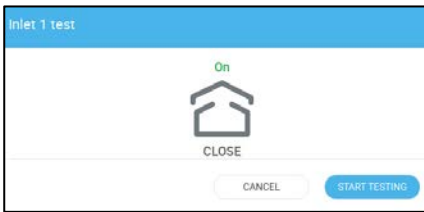

Figure 45: Testing the Potentiometer

- 2. In Devices and Sensors, go to the inlet controlled by the potentiometer and click Test. The test icon appears.



- If the wiring is correct:
  - When the inlet is fully closed, the voltage should be low (for example 0.5V).
  - When the inlet is fully open, the voltage should be high (for example 3.2V).
- If the voltages are reversed, that means that the wiring is reversed.



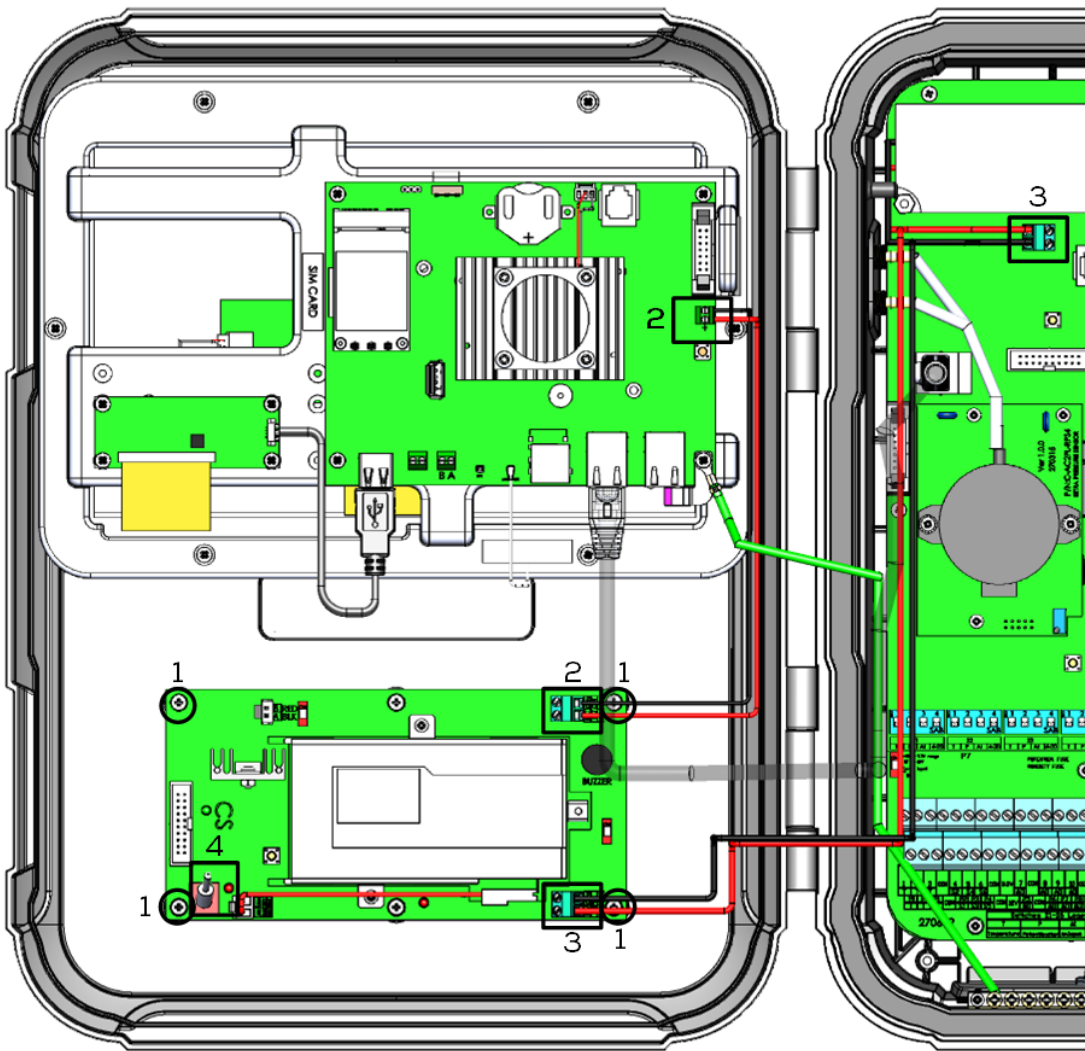

Figure 47: Trio Alarm Battery Installation

1	Attach the card with four screws
2	Attach the wires between the Trio battery and the alarm battery.
3	Attach the wires between the alarm battery and the CPU card.
4	On/off toggle switch

- The toggle switch:
  - When the switch is in the upper position, the backup delivers emergency power to the display card and cell modem when main power is lost.
  - When the switch is in the middle or bottom position, the backup is disconnected from the display card and cell modem; no power is delivered.
  - The LED next to the toggle switch is lit when the switch is in the upper position.

## 8.2 Detailed Description

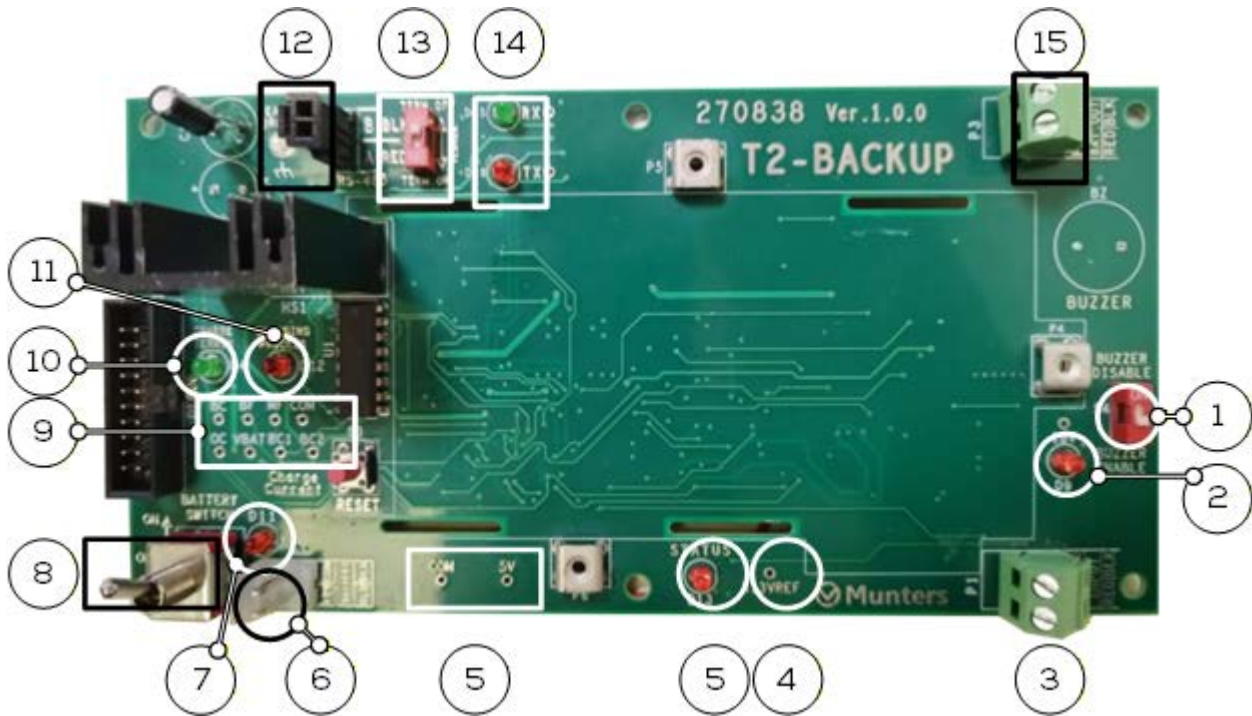

Figure 48: Battery Board Detailed Schematic

##	Component	Functionality	Note
1	Dip switch S4 "BUZZER" Disable/Enable	Restores the battery to working condition after being on a shelf or after transportation	
2	LED D9 "18V"	Indicates the presence of the charger voltage	
3	P1	Input terminal	An input terminal that receives 12V voltage from the motherboard.
4	TP2, TP3	Test points	5V, 3.3VREF (for technicians only)
5	LED D13 "Status"	Indicates the character of the application running	<ul style="list-style-type: none"> <li>Blinks during normal application operation.</li> <li>Remains steadily ON or OFF if the application is stalled.</li> </ul>
6	P2	Battery connector	
7	LED D11	Indicates that the battery is connected to the board	
8	Toggle switch S1 "BATTERY SWITCH"	Connects the battery to the board	During transportation or being on the shelf must be in the state "OFF"

##	Component	Functionality	Note
9	Measurements TP1 group	Test points	<ul style="list-style-type: none"> <li>• BC - Battery Current, see below.</li> <li>• BF - Battery Fail, default Low (<math>\leq 150</math> mV)</li> <li>• MF - Main Fail, default High (4.75-5.0V)</li> <li>• OC - <u>reserve</u> (the Display Card has on its input overcurrent protection device).</li> <li>• VBAT - Battery voltage</li> <li>• BC1-BC2 - Charging battery current</li> </ul> (for technicians only)
10	LED D4 "Charge Termin"	Indicates the charging process termination	Lights up when the battery is being discharged by an artificial load and when the battery is fully charged.
11	LED D12 "Charging process"	Indicates the charge/discharge process	<ul style="list-style-type: none"> <li>• High-speed blinking when discharging.</li> <li>• Low-speed blinking when charging.</li> <li>• Turns OFF when charging is completed</li> </ul>
12	P8	Communication terminal	RS-485 communication with Display Card
13	DIP Switch S2	Connects termination resistor for RS-485 communication	This DIP switch must be always kept in the position marked "TERM.OFF".
14	N/A		
15	P3	Output terminal	<ul style="list-style-type: none"> <li>• Battery voltage on it appears when a main power 12V outage occurs.</li> <li>• To be connected to Display Card (for technicians only)</li> </ul>

### 8.3 Preparing the Battery for Operation After Transportation or Storage

*NOTE* Refer to Figure 48 when numbers (#) are mentioned regarding the battery board's components.

1. Apply 12V to the input terminal P1 (#3).
2. Set switch S1 (#8) to the ON position.
3. Move DIP switch S4 (#1) to the ON position.
4. Press the Reset button (refer to #8 in Figure 11 , page 29) for 1–2 seconds.
  - LED D12 (#12) begins flashing rapidly (battery is discharging).
  - LED D4 (#10) turns on.
5. Return DIP switch S4 to the OFF position. See Note 1.
  - When the battery voltage reaches  $11.9 \pm 0.1$  V, discharging ceases and the system automatically begins charging the battery. At this point, LED D4 turns off.
  - Charging may take several hours.
  - During charging, LED D12 flashes slowly while the green LED D4 remains off.
  - When the battery is fully charged, LED D12 (#11) turns off and LED D4 (#10) turns on.

Note 1: DIP switch S4 is used to restore batteries that have been unused for a long time (for example, during storage or transport). It works by performing a deep discharge followed by a full recharge, which helps remove buildup on the battery electrodes.

- This process may take 1–4 hours, depending on the battery's condition.
- Use the same procedure when installing a new battery.

## 9 Appendix B: External Device (Previous Versions)

Table 5: Output Devices

Device type	Maximum Number of Devices	Number of Relay Devices	Number of Analog Devices
Cooling	2	2	N/A
Central Exhaust Cooling	2	2	N/A
Heaters	6	6	6
Inlets	2	2	2
Outlets	1	N/A	1
Tunnel Doors/Curtains	2	2	2
Fans Exhaust/Tunnel	20	20	8
Central Exhaust Fans	20	20	8
Stir Fan	1	1	1
Sprinkler	1	1	N/A
Timer	5	5	N/A
Auger	2	2	N/A
Feeder	1	1	N/A
Lighting	4	4	N/A
As Relay	30	30	N/A
As Analog Out	8	NA	8
Alarm	1	1	N/A

Table 6: Sensors

Device type	Analog Sensors	Digital Sensors
Temperature Sensors	12	N/A
Humidity Sensors	2	N/A
CO2 Sensors	1	N/A
Ammonia Sensors	1	N/A
Pressure Sensors	2	N/A
Potentiometers	4	N/A
Water Meters	N/A	4

Device type	Analog Sensors	Digital Sensors
Gas Meters	N/A	3
Aux. Input	N/A	4
Feeder Line Sensor	N/A	1
Measuring Fan	N/A	1

Table 7: Trio 20 Swine STD – R4

Devices/Sensors	Output			Measurements	
	Total	Relay	0-10V	Analog	Digital
Cooling	2	2			
Heaters	6	6	6		
Inlets	2	2	2		
Outlets	1	NA	1		
Tunnel Doors/Curtains	2	2	2		
Fans Exhaust/Tunnel	20	20	8		
Stir Fan	1	1	NA		
Sprinkler	1	1			
Timer	5	5			
Feeder	1	1			
As Relay	30	30	NA		
As Analog Output	8	NA	8		
Alarm	1	1			
Temperature Sensors				12	
Humidity Sensors IN				1	
CO2 Sensors				1	
Ammonia Sensors				1	
Pressure Sensors				2	
Potentiometers				4	
Power Meter					2
Gas Meter					2
Water Meters					1
Aux. Input					4
Feeder Line Sensor					1

Table 8: Trio 20 Swine STD - R3

Devices/Sensors	Output			Measurements	
	Total	Relay	0-10V	Analog	Digital
Cooling	2	2			
Heaters	4	4	4		
Inlets	2	2	2		

	Output			Measurements	
Outlets	1	N/A	1		
Tunnel Doors/Curtains	2	2	2		
Fans Exhaust/Tunnel	12	12	8		
Stir Fan	1	1	1		
Sprinkler	1	1			
Timer	5	5			
Feeder	1	1			
As Relay	20	20	N/A		
As Analog Output	8	N/A	8		
Alarm	1	1			
Temperature Sensors				12	
Humidity Sensors IN				1	
CO2 Sensors				1	
Ammonia Sensors				1	
Pressure Sensors				2	
Potentiometers				4	
Power Meter					X
Gas Meter					X
Water Meters					1
Aux. Input					4
Feeder Line Sensor					1

Table 9: Trio 20 Swine STD – R2

Devices/Sensors	Output			Measurements	
	Total	Relay	0-10V	Analog	Digital
Cooling	2	2			
Heaters	4	4	4		
Inlets	2	2	2		
Outlets	1	NA	1		
Tunnel Doors/Curtains	2	2	2		
Fans Exhaust/Tunnel	8	8	8		
Stir Fan	1	1	NA		
Sprinkler	1	1			
Timer	5	5			
Feeder	X	X			
As Relay	20	20	NA		
As Analog Output	8	NA	8		
Alarm	1	1			
Temperature Sensors				12	
Humidity Sensors IN				1	

	Output			Measurements	
CO2 Sensors				1	
Ammonia Sensors				1	
Pressure Sensors				2	
Potentiometers				4	
Power Meter					X
Gas Meter					X
Water Meters					1
Aux. Input					4
Feeder Line Sensor					X

# 10 Appendix C: Service Manual

- Maintenance
- Trouble Shooting
- Spare Parts

## 10.1 Maintenance

Perform the following steps to maintain your unit.

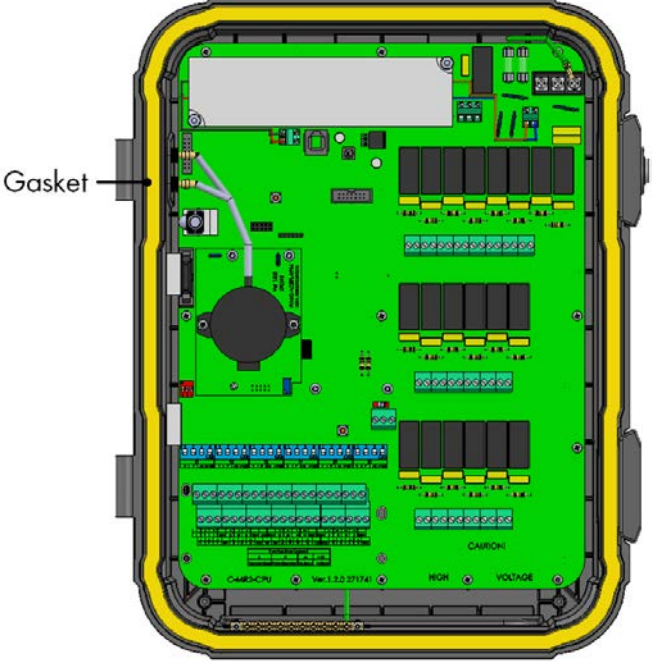
<ul style="list-style-type: none"><li>• Checking the Battery Level: Check the battery once a year. The output must be 2.7 volts (minimum). Authorized personnel only must replace the battery if the output is below the minimum required level or every five years.</li></ul>	
<ul style="list-style-type: none"><li>• Visually inspect your unit once a year. Make sure that there are no signs of corrosion or residue on the PCBs. If these issues appear, it means that:</li></ul>	
<ul style="list-style-type: none"><li><ul style="list-style-type: none"><li>○ the TRIO is installed in an environment with high humidity, ammonia content, or some other destructive agent.</li></ul></li></ul>	
<ul style="list-style-type: none"><li><ul style="list-style-type: none"><li>○ There is a lack of (silicon) sealing or that the sealing has degraded.</li></ul></li></ul>	
<ul style="list-style-type: none"><li>• Make sure that the silicon seal around the PGs installed in the knockouts is not cracked.</li></ul>	
<ul style="list-style-type: none"><li>• Check that the gasket is not cracked.</li></ul>	 <p>The diagram shows the internal layout of a device, including a green PCB with various components, a battery pack, and a yellow gasket. A label 'Gasket' with a pointer indicates the location of the gasket on the left side of the device. The PCB has labels for 'CHARGE', 'VOLTAGE', and 'HIGH'. The battery pack is labeled 'CAUTION'.</p>

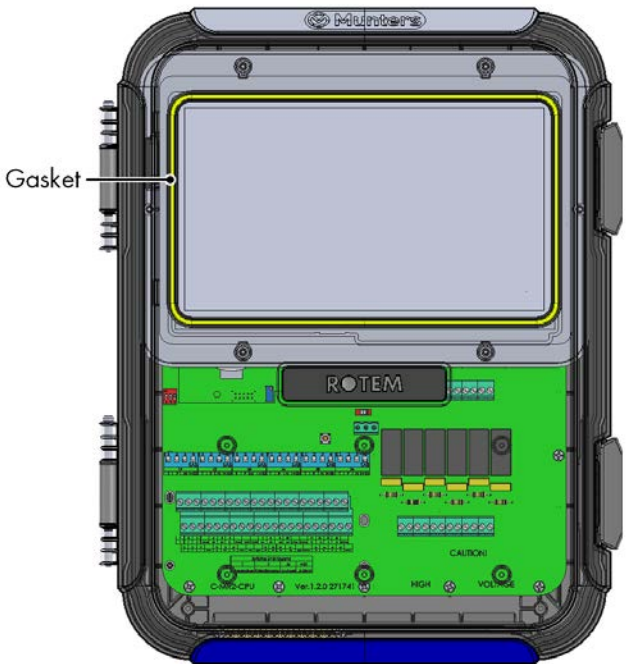
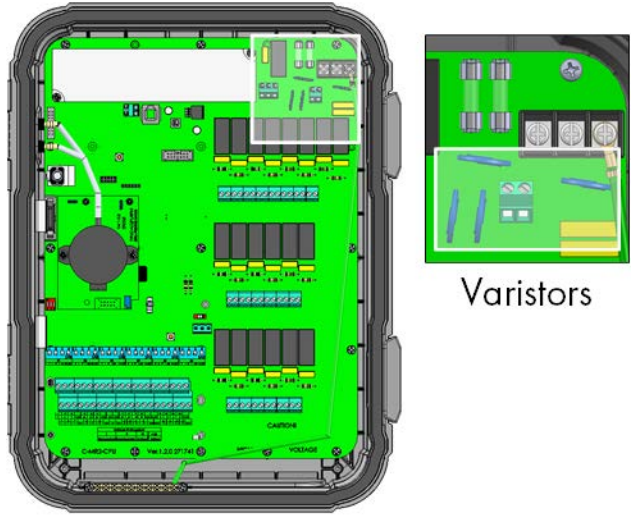
<ul style="list-style-type: none"><li>• Check that the gasket around the touch screen is not cracked.</li></ul>	 <p>The diagram shows the back cover of the device with the gasket around the touch screen highlighted in yellow. A label 'Gasket' points to this yellow area. The internal components, including the green PCB and the 'ROTEM' label, are visible through the transparent back cover.</p>
<ul style="list-style-type: none"><li>• Look for any signs of burns or browning around the varistors.</li></ul>	 <p>The diagram shows the back cover of the device with a callout showing a close-up of the varistors. The callout is labeled 'Varistors' and shows a close-up of the varistors on the green PCB.</p>
<ul style="list-style-type: none"><li>• Inspect the shield wiring and main grounding cable; ensure that they are properly connected to the proper ports.</li></ul>	

### 10.2 Trouble Shooting

- Internet
- Electronic Components

#### 10.2.1 INTERNET

The following section describes how to trouble shoot internet problems. If there is no internet connection:

1. Go to System > General Settings > Network Screen. Verify that there is an IP address.
2. Check the cable connections between the switch and the TRIO.
3. Verify that the unit is powered.

*NOTE If there is no internet connection, the Main Menu Internet icon is marked.*



## 10.2.2 ELECTRONIC COMPONENTS

**Problem:** The touch screen doesn't turn on up after applying 115/230VAC.

**Solution:** Open the TRIO door and:

1. Check main 115/230VAC 3A fuse F2.
  - If required, replace fuse.
2. Check the 12V terminal voltage (COM & 12V).
  - If there is no voltage, there is a problem with the Switched Power Supply. Replace the power supply.
3. Verify that the 5V and 3.3V indicative LEDs of the I/O power board are lit.
4. Verify that the flat cable connecting the I/O board and the display board is in place.
5. Verify that the Green Status LED is flashing.
6. On the TRIO display board, verify that the:
  - RED Status LED is flashing
  - Display's flat cable is firmly hooked up to its connector.

**Problem:** The screen doesn't reflect changes made in the analog inputs.

**Solution:**

1. Verify that the position of Dip Switch (S1-S6) corresponds with the relevant analog input.
2. Verify that the analog input terminals' mapping corresponds to the actual wiring.
3. Check that the terminal wire connection of Analog Input of interest coincides with the analog input chosen on the touch screen.

**Problem:** The screen doesn't reflect the changes in digital inputs.

**Solution:** Verify that the digital input terminals' mapping corresponds to the actual wiring.

**Problem:** The Alarm Relay doesn't operate.

**Solution:** Check fuse F4.

- By default, alarm relay contacts "NO-COM" should be closed.

**Problem:** The analog output voltage doesn't correspond to the voltage defined on the corresponding analog output terminal.

**Solution:** Check the load value. The maximum analog output load is 15 mA.

**Problem:** An analog output terminal has no output voltage.

**Solution:** Verify that the analog output terminals' mapping corresponds to the actual wiring.

**Problem:** The display screen appears but does not respond to any touch.

**Solution:** Check the USB cable between the touch screen card and the TRIO display card.

**Problem:** There is no 3.3V output for to power the potentiometer(s).

**Solution:** There is a PPTC fuse F1 on the 3.3V line. Disconnect the potentiometers and using a DVM, check the resistance on the terminal between the 12V output and common ground (COM). The reading should indicate an open circuit.

- If not, the line is damaged.

**Problem:** The end user doesn't see changes in the data tables.

**Solution:**

1. Check the Internet cable, going from RJ-45 connector (marked as Ethernet-2). Verify that the connector's LEDs are flashing.
2. Check the Internet cable, going from the power card to the TRIO display's card RJ-45 connector (marked as Ethernet-1). Verify that the connector's LEDs are flashing.

## 10.3 Spare Parts

- Preliminary Information
- Trio Minimal Spare Parts
- Trio 20 Container Spare Parts
- Trio 20 Door Card Spare Parts
- Trio 20 Main Container Spare Parts
- Additional Options
- Cards

### 10.3.1 PRELIMINARY INFORMATION

	Trio 20
Container	A
Door Cards	B
Main Container Cards	C
Cables and Harnesses	D
MPN	Munters Part Number
DPN	Distributor Part Number

## 10.3.2 TRIO MINIMAL SPARE PARTS

Munters Israel recommends that managers of farms equipped with Trio Controllers keep (as a minimum stock) the following spare parts on hand. Doing so simplifies maintenance and repairs of the Trio units.

### 10.3.2.1 Global Customers

P/N	Description
940-99-00002	TRIO-20 LCD KIT (DISPLAY + LVDS CARD + USB CABLE) (SP-250061)
940-99-00003	TRIO-20 CPU (TRIO 20-MAIN)
940-99-00004	TRIO 20 DISPLAY CARD (TRIO-DISPLAY)
940-99-00165	TRIO-PIG-EN- DISPLAY IMX8 CARD WITH HEATSINK AND FAN

### 10.3.2.2 Chinese Customers

P/N	Description
940-99-00002	TRIO-20 LCD KIT (DISPLAY + LVDS CARD + USB CABLE) (SP-250061)
940-99-00157	TOUCH MODULE FOR TRIO LCD 10.1" (250061)VT101C-KC17-B07A VITEK (SP-250064)
940-99-00003	TRIO-20 MAI, CPU
940-99-00166	TRIO-PIG-CN- DISPLAY IMX8 CARD WITH HEATSINK AND FAN & ANTENNA WIFI

### 10.3.3 TRIO 20 CONTAINER SPARE PARTS



ID No.	Description	Catalog Number	Note
A1.1	Trio-20 FRONT DOOR TOUCH PLASTIC PART	MPN: 940-99-00005	
		DPN:	
A1.2	Trio-20 PLASTIC BOX BASE (SP - 207124)	MPN: 940-99-00112	
		DPN:	
A1.3	Trio HINGE PLASTIC PIN V1.0.0 (SP-207128)	MPN: 940-99-00019	
		DPN:	
A2.1	Trio-20 PANEL PLASTIC PART BLUE LOGO MUNTERS + PART BLUE	MPN: 940-99-00001	OR
		DPN:	
A2.2	Trio PANEL PLASTIC PART RED RAL 3020 NO LOGO (SP-207138)	MPN: 940-99-00045	
		DPN:	
A3.1	ONE / ONE PRO - LATCH GENERAL LOCK PLASTIC PART + LOCK FOR LATCH	MPN: 900-99-00217	
		DPN:	
A3.2	GENERAL PLASTIC LATCH	MPN: 900-99-00216	
		DPN:	
A4	Trio-20 LCD HOLDER V1.0.0 (SP-207125)	MPN: 940-99-00024	
		DPN:	
A5	P4 SCREEN GASKET SILICONE 35 SHORE 75CM (EXTRUSION PROCESS) (SP-204079)	MPN: 940-99-00020	
		DPN:	
A6	MID-RANGE MAIN GASKET V1.0.0 (SP-207122)	MPN: 940-99-00021	
		DPN:	

### 10.3.4 TRIO 20 DOOR CARD SPARE PARTS

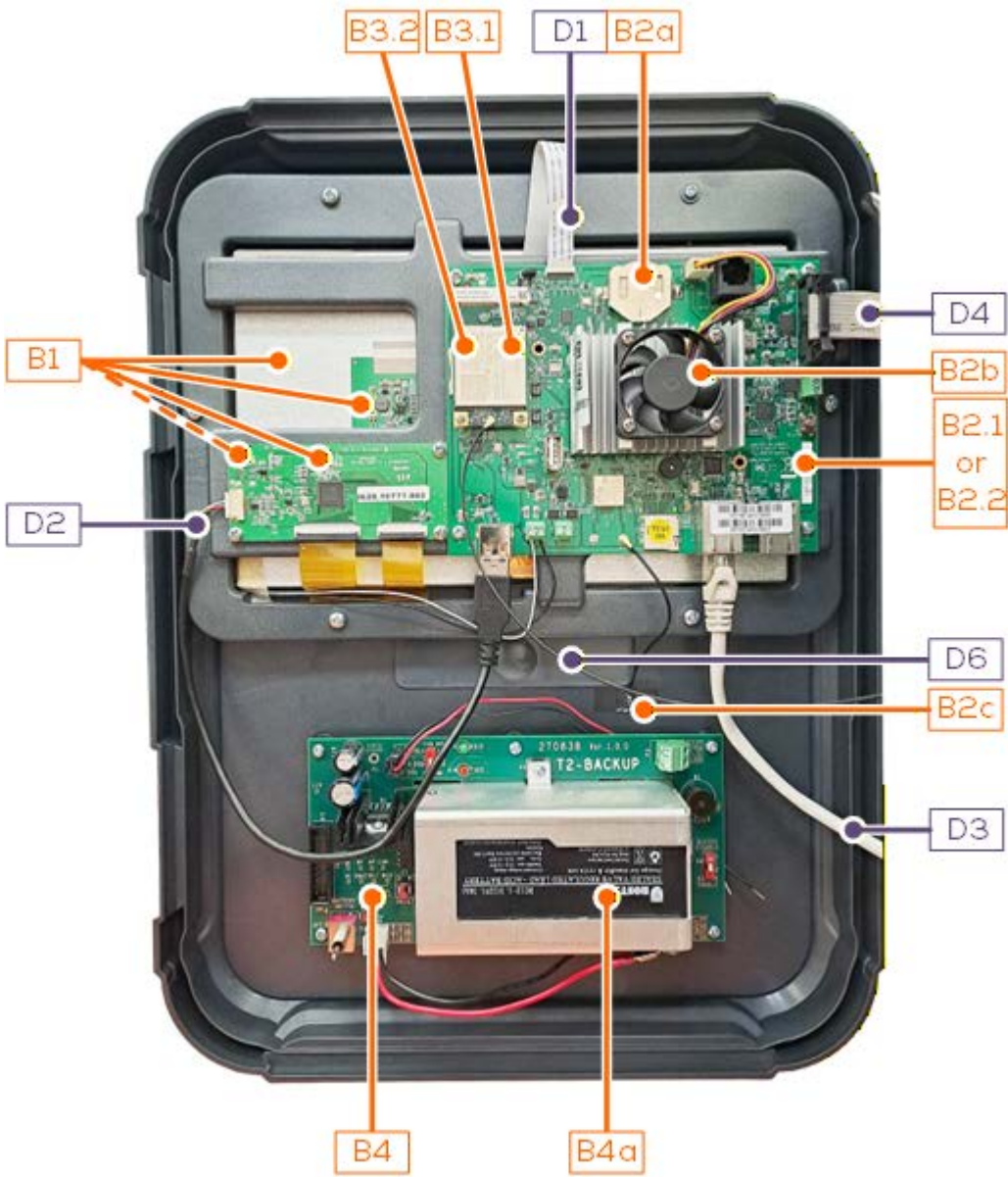

ID No.	Description	Catalog Number	Notes
B1	TRIO-20 LCD KIT (DISPLAY + LVDS CARD), [+ USB CABLE *	MPN: 940-99-00002	
		DPN:	
B2.1	TRIO-POU-EN- DISPLAY CARD WITH HEATSINK AND FAN	MPN: 940-99-00165	OR
		DPN:	
B2.2	TRIO-PIG-CN DISPLAY CARD IMX8 NEXCOM	MPN: 940-99-00188	
		DPN:	
B2a	BAT COIN 3V FOR SOCKET (SP-450009)	MPN: 999-99-00386	
		DPN:	
B2b	FAN 12V 0.62W 7000RPM 8CFM (SP-240201)	MPN: 940-99-00177	
		DPN:	
B2c	TRIO 20 ANTENNA WIFI MOLEX 15cm CABLE U.FL/I-PEX MHF 2.4GHz 2.8dBi 50ohm (SP-491009)	MPN: 940-99-00035	
		DPN:	
B3.1	GLOBAL LTE CELL MODEM W/O SIM SOCKET-EG21GGB-MINIPCIE (SP-490099)	MPN: 904-99-00106	
		DPN:	
B3.2	Trio Cell Modem Global SIM (SP-221011)	MPN: 904-99-00118	
		DPN:	
B4	TRIO HIGH RANGE POWER BACKUP CARD (T2-BACKUP)	MPN: 940-99-00167	
		DPN:	
B4a	BAT Pb 12V 1.2AH NP12-1.2AH NPP (SP-450042)	MPN: 940-99-00178	
		DPN:	

ID No.	Description	Catalog Number
D1	VIDEO FLAT CABLE 0.02" (0.50 mm) Type 1,152.4 mm	MPN: 940-99-00012
		DPN:
D2	USB CABLE FOR Vitek\Ampire DISPLAY (SP-140672)	MPN: 940-99-00027
		DPN:
D3	NETWORK CABLE RJ485 (8 WIRES, 0.5 METERS)	MPN: 940-99-00011
		DPN:
D4	FLAT FF14P 25CM F"D>_V1.0.0 (SP-141161)	MPN: 999-99-00457
		DPN:
D6	CABLE GSM 40cm M.SMA-UFL (SP-490008)	MPN: 940-99-00036
		DPN:







### 10.3.6 ADDITIONAL OPTIONS

ID No.	Description	Catalog Number	Notes
ADO 1	TEMPERATURE SENSOR BLACK-RTS-2-POU	MPN: 918-01-00001 DPN:	
ADO2.1a	RHS10 HUMIDITY SENSING TIP SE (SP-RHS10-TIP-SE)	MPN: 917-99-00214 DPN:	For +/SE Sensor
ADO2.2	HUMIDITY SENSOR-RHS-PRO-POU-PLS	MPN: 917-04-10002 DPN:	
ADO2.2a	HUMIDITY SENSOR PRO TIP - (RHS-PRO-TIP)	MPN: 917-99-00002 DPN:	For Pro Sensor
ADO 3	TRIO GLOBAL LTE CELL MODEM & EXTERNAL ANTENNA SET	MPN: 940-99-00049 DPN:	
ADO 4	STATIC PRESSURE SET - AC3G/SE/PL/TRIO - POU	MPN: 901-99-00025 DPN:	
ADO 4.a	TUBES AND FILTERS FOR RPS (NO RPS CARD)	MPN: 999-99-00503 DPN:	
ADO 5.1	TRIO 20 SCALE CARD 2SCL WITH 230V POWER SUPPLY	MPN: 940-99-00015 DPN:	OR
ADO 5.2	TRIO 20 SCALE CARD 6SCL WITH 230V POWER SUPPLY	MPN: 940-99-00016 DPN:	OR
ADO 5.3	TRIO 20 SCALE CARD 2SCL WITH 115V POWER SUPPLY	MPN: 940-99-00017 DPN:	OR
ADO 5.4	TRIO 20 SCALE CARD 6SCL WITH 115V POWER SUPPLY	MPN: 940-99-00018 DPN:	
ADO 6	CO2-PIG-EN-MUR	MPN: 919-01-10005 DPN:	
ADO 7	AMMONIA-POU-MUN	MPN: 929-01-00002 DPN:	

### 10.3.7 CARDS



- Door Cards
- Main Container Cards



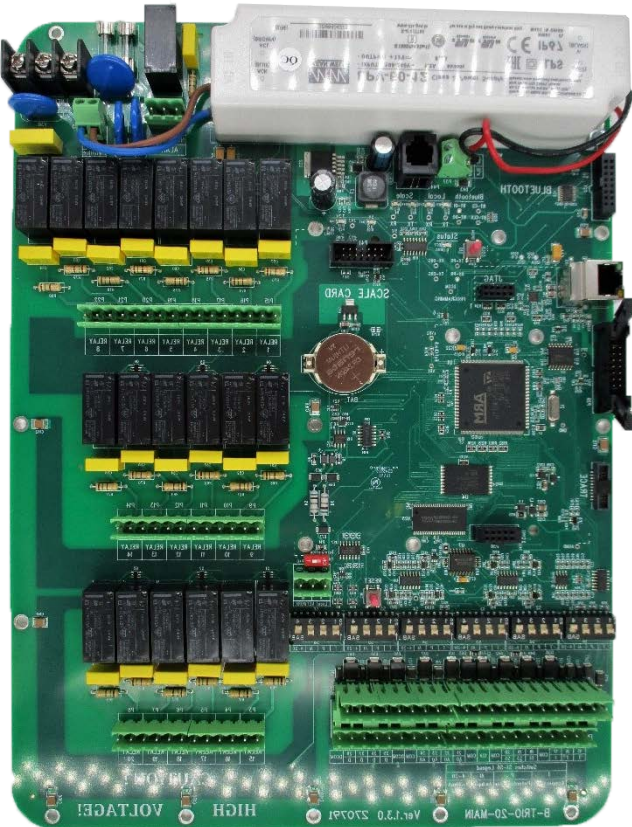

10.3.7.1 Door Cards

Card	Description	Catalog Number
	<p>250061: LCD TFT 10.1" VT101C-KC17- B07A Vitek</p> <p>Or</p> <p>AM- 1024600O2TMQW- TA0H Ampire</p> <p>Or</p> <p>TWS2101RBTV20C APEX</p>	<p>940-99-00002</p>
	<p>140672: USB CABLE FOR Vitek\Ampire DISPLAY</p>	<p>940-99-00027</p>
	<p>208027:TRIO- DISPLAY PC BOARD IMX8 NEXCOM</p>	<p>940-99-00165 (EN)</p> <p>940-99-00188 (CN)</p>
	<p>204152: FAN FOR SOM CARD HEATSINK</p>	<p>940-99-00025</p>

Card	Description	Catalog Number
	<p>491009: ANTENNA WIFI MOLEX 15cm CABLE U.FL/I-PEX MHF 2.4GHz 2.8dBi 50ohm/YF0026AA Quectel</p>	<p>940-99-00035</p>

10.3.7.2 Main Container Cards

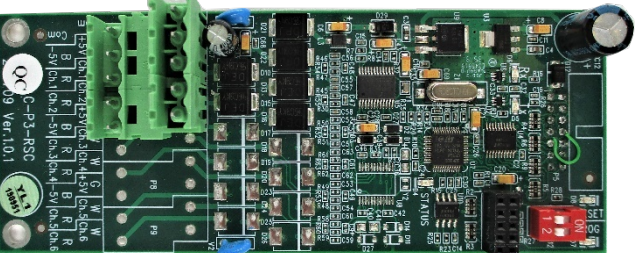
Card	Description	Catalog Number
	<p>R-TRIO-20-MAIN: MUNTERS ROTEM MIDDLE RANGE 2 CPU</p>	<p>940-99-00003</p>
	<p>370193: SWPS LPV- 60-12 Mean Well 100-240V 12V 60W</p>	<p>900-99-00264</p>

Card	Description	Catalog Number
	<p>STATIC PRESSURE SET - AC3G/SE/PL/TRIO - POU</p>	<p>901-99-00025</p>
	<p>TUBES AND FILTERS FOR RPS (NO RPS CARD)</p>	<p>999-99-00503</p>
	<p>R-TRIO-RSC-2: TRIO 20 SCALE CARD 2CH</p>	<p>940-99-00013</p>
	<p>R-TRIO-RSC-6: TRIO 20 SCALE CARD 6CH</p>	<p>940-99-00014</p>

# 11 Appendix D: Trio Expansion

- Introduction
- Expansion 10
- Expansion 20
- Mapping Devices in Expansion
- Expansion Specifications
- Expansion Spare Parts

## 11.1 Introduction

- Observe all the safety rules given in Precautions, page 12.
- Install the unit according to the instructions given in Unit Installation, page 26.

## 11.2 Expansion 10

- Expansion Layout
- TRIO to TRIO 10 Expansion Wiring
- High Voltage Relays
- Power

### 11.2.1 EXPANSION LAYOUT

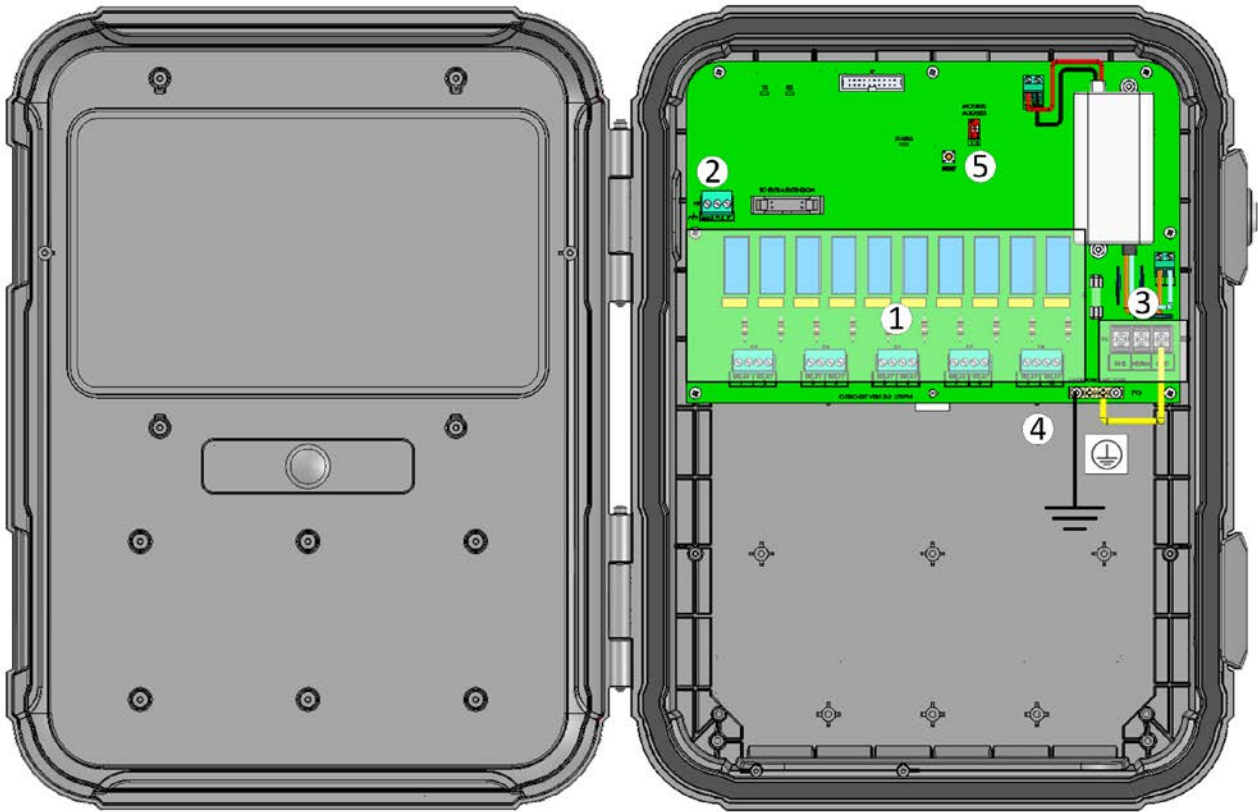

Figure 49: Board layout

1	10 relays
2	RS-485 ports
3	Power ports
4	Ground strip
5	Address dipswitch (refer to Address, page 135)

### 11.2.2 TRIO TO TRIO 10 EXPANSION WIRING

Connecting the Trio to its Expansion Unit consists of three steps:

- Wiring
- Address
- Restart

### 11.2.2.1 Wiring

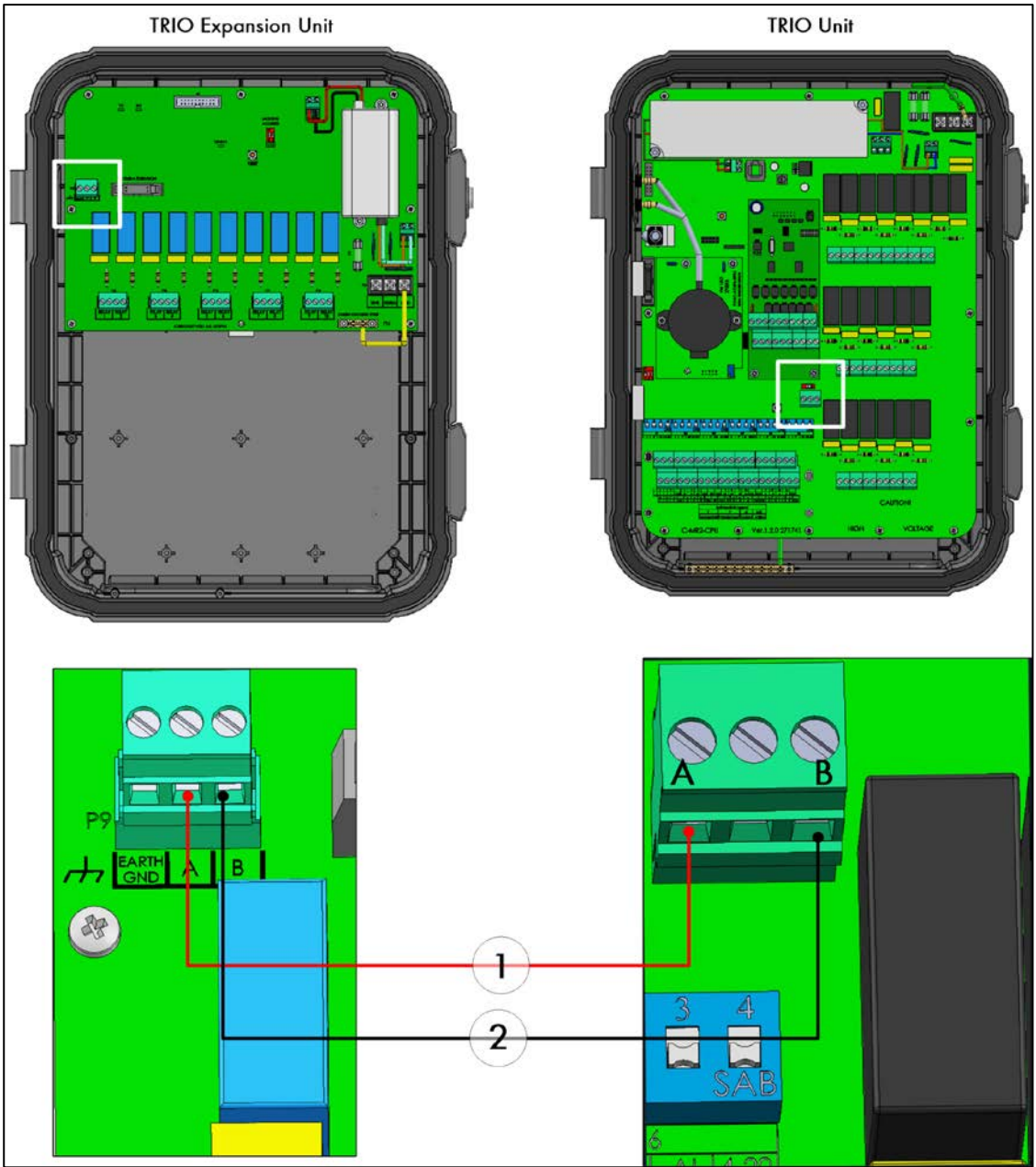

Figure 50: Wiring diagram

- The cable between the controller and the expansion unit should be a 4 wire twisted shielded cable (22 or 24 AWG).
- 1 – red wire
- 2 – black wire

### 11.2.2.2 Address

The Trio can support one expansion unit. Verify that both dipswitches in the Modbus Address are set to ON.

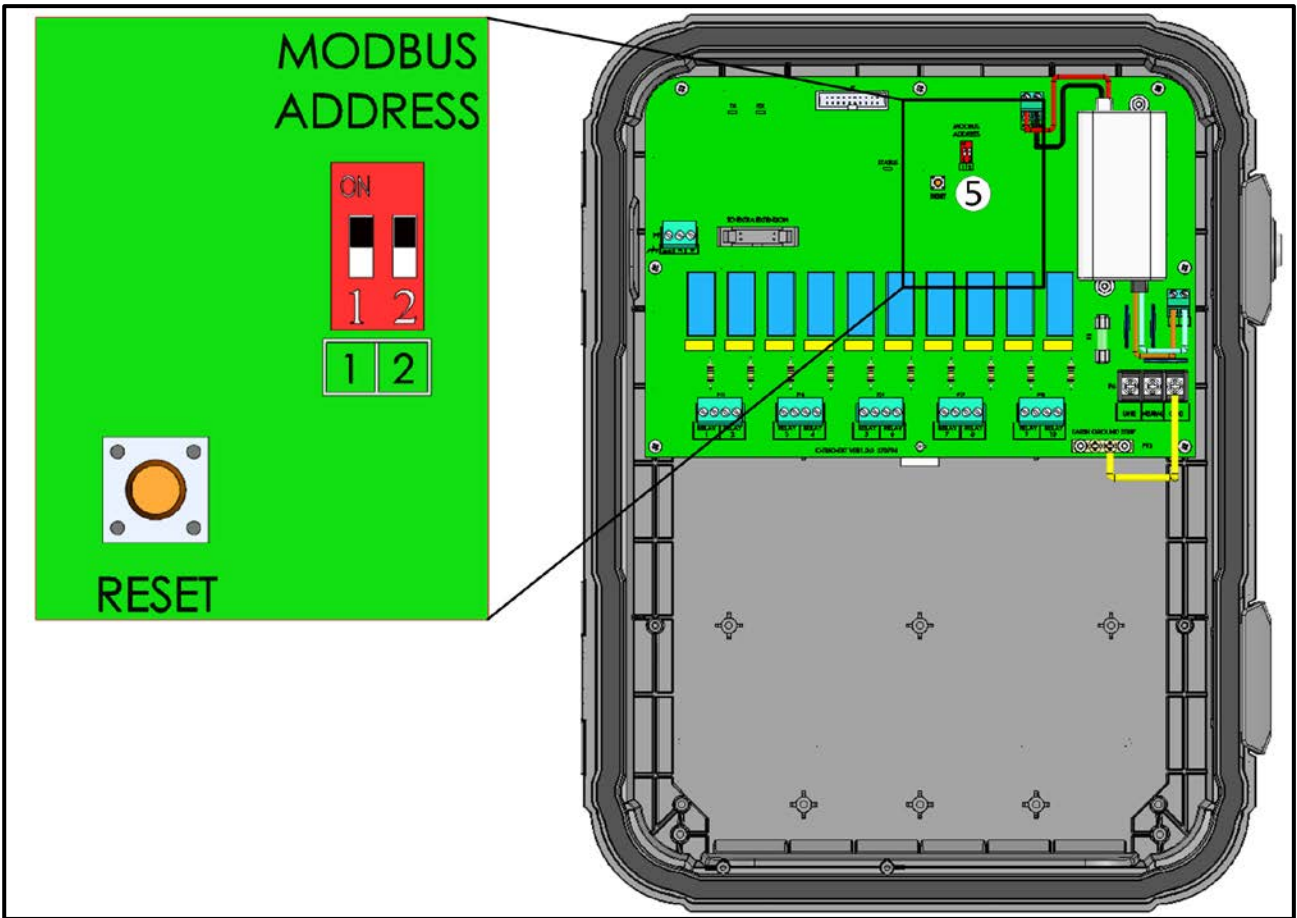

Figure 51: Expansion Address

### 11.2.2.3 Restart

After connecting the units and verifying the Modbus address, reset the factory settings.

1. Go to System > General Settings > .

2. Click .

3. Follow the on-line instructions. You have the option of backing up the settings. Refer to the User Manual for more information.

### 11.2.3 HIGH VOLTAGE RELAYS

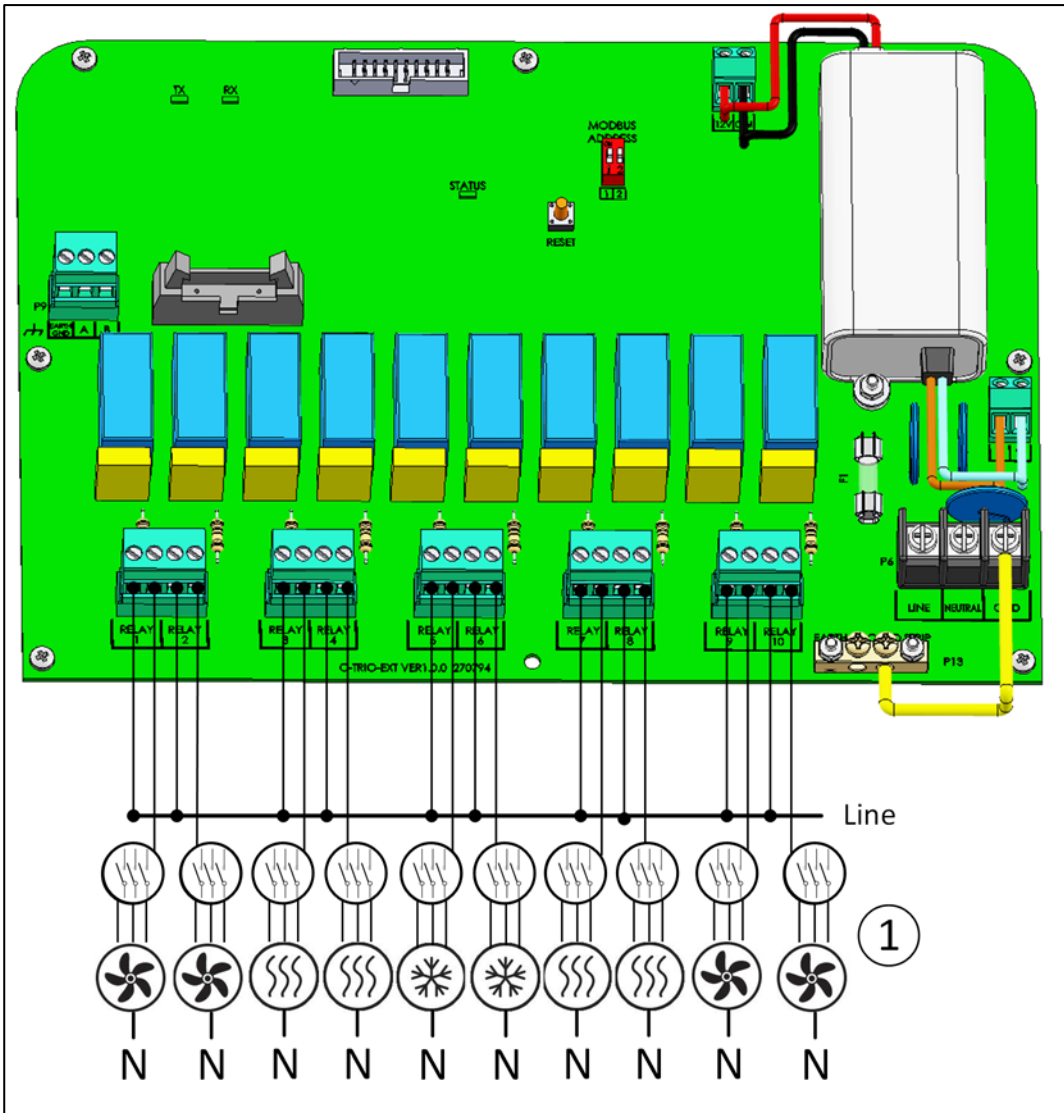

Figure 52: High voltage devices (examples)

1	Example of devices
---	--------------------

NOTE The relays control motors and heating devices via contactors, not directly.

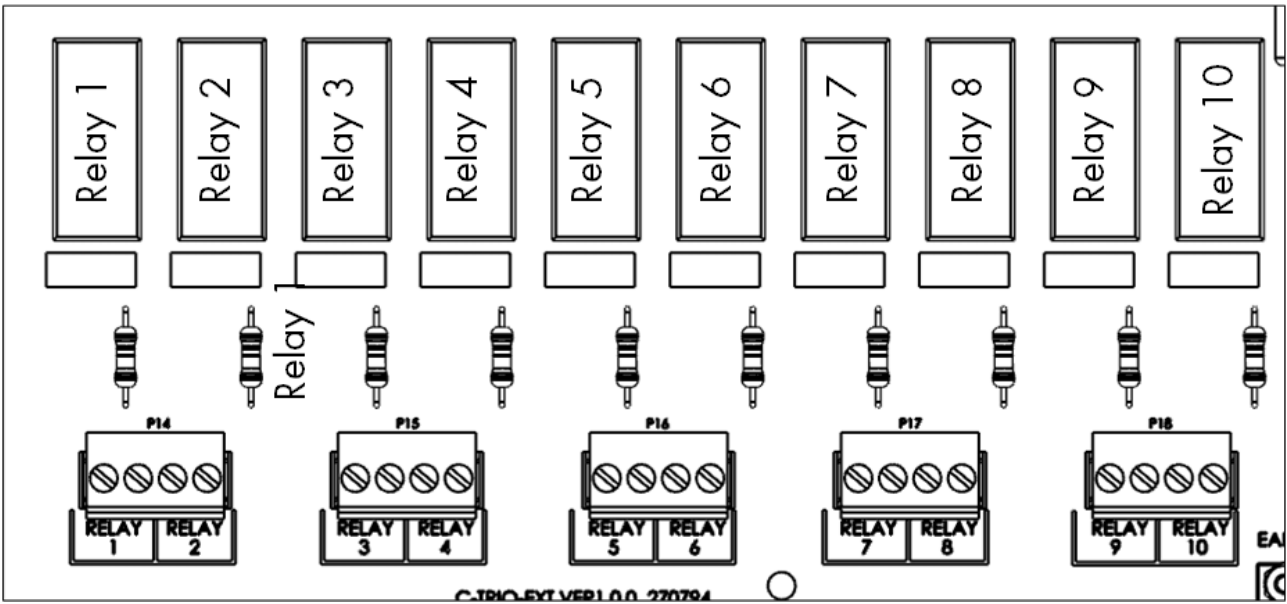

Figure 53: Relay and port numbering

### 11.2.4 POWER

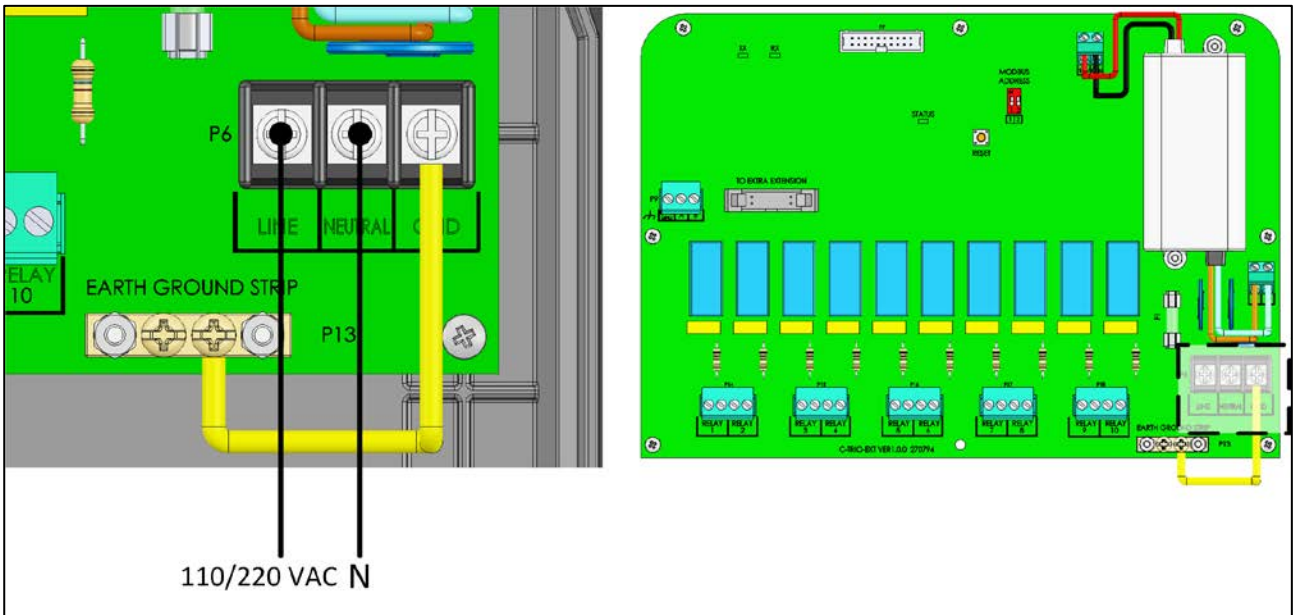

Figure 54: Power ports

### 11.3 Expansion 20

- Expansion Layout
- Expansion Wiring Diagrams
- High Voltage Relays
- Power

#### 11.3.1 EXPANSION LAYOUT

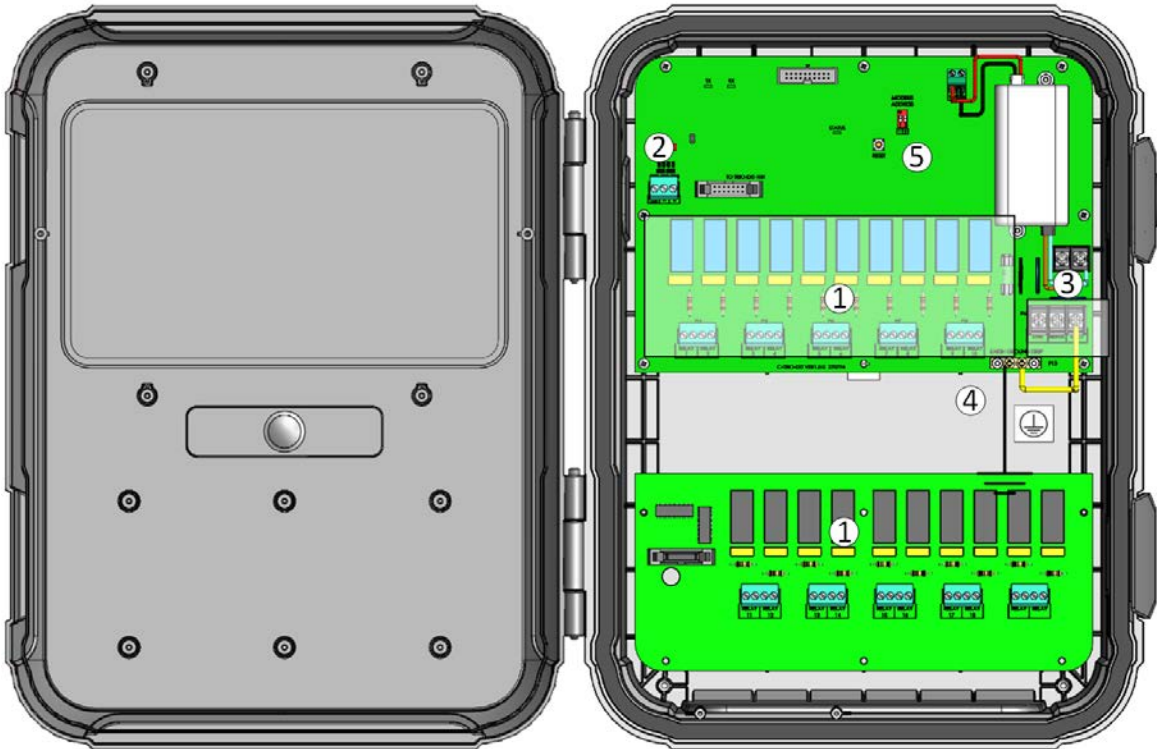

Figure 55: Board layout

1	20 relays
2	RS-485 ports
3	Power ports
4	Ground strip
5	Address dipswitch (refer to Address, page 135)

### 11.3.2 EXPANSION WIRING DIAGRAMS

- TRIO to TRIO 20 Expansion Wiring
- High Voltage Relays
- Alarms and Power

#### 11.3.2.1 TRIO to TRIO 20 Expansion Wiring

Connecting the Trio to its Expansion Unit consists of three steps:

- Wiring
- Address
- Restart

#### 11.3.2.2 Wiring

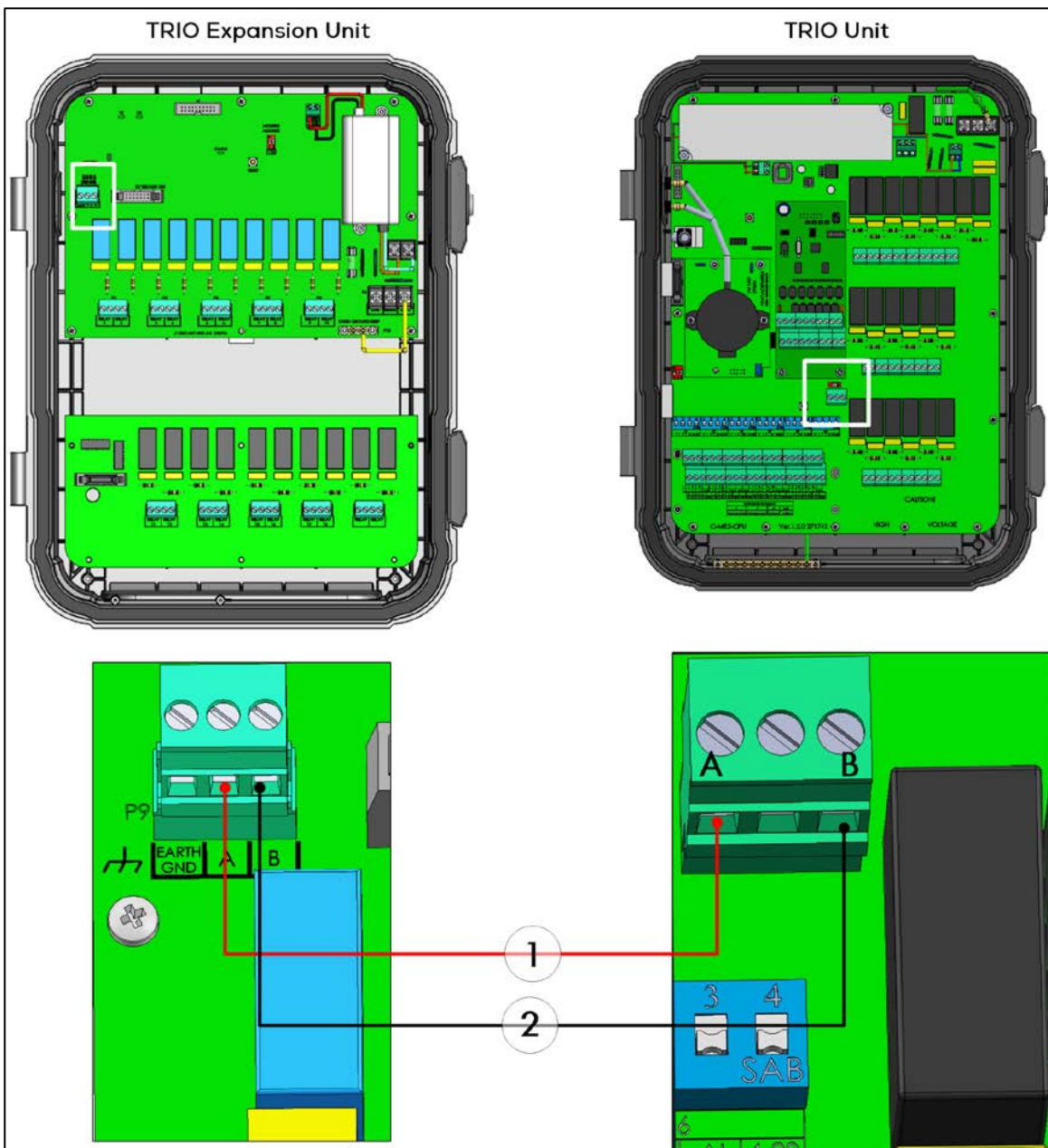

Figure 56: Wiring diagram

- The cable between the controller and the expansion unit should be a 4 wire twisted shielded cable (22 or 24 AWG).
- 1 – red wire
- 2 – black wire

### 11.3.2.3 Address

The Trio can support one expansion unit. Verify that both dipswitches in the Modbus Address are set to ON.

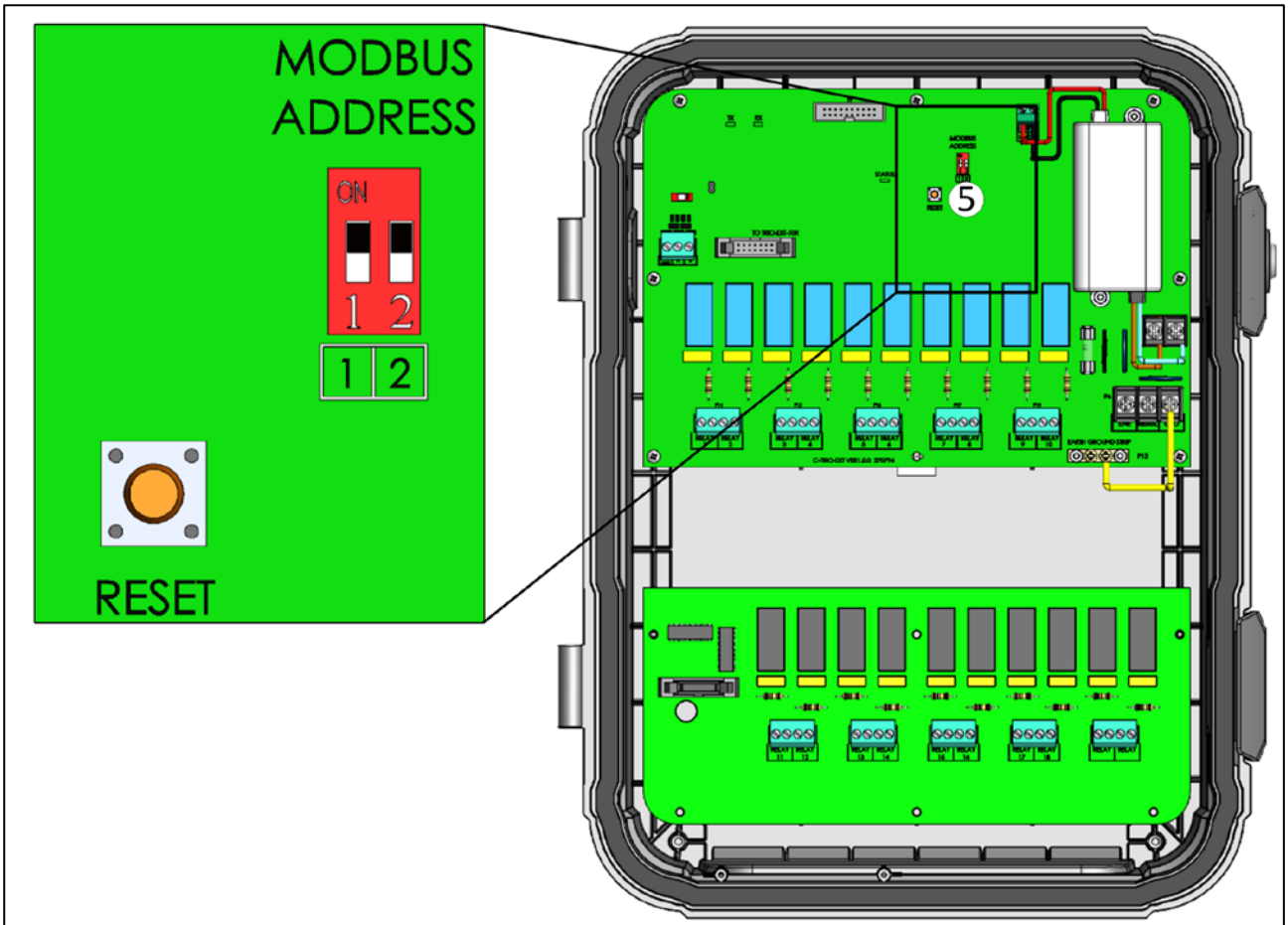

Figure 57: Expansion Address

### 11.3.2.4 Restart

After connecting the units and verifying the Modbus address, reset the factory settings.

1. Go to System > General Settings > .

2. Click . The button contains the text 'Reset Factory Settings' and a 'Reset' button.

3. Follow the on-line instructions. You have the option of backing up the settings. Refer to the User Manual for more information.

### 11.3.3 HIGH VOLTAGE RELAYS

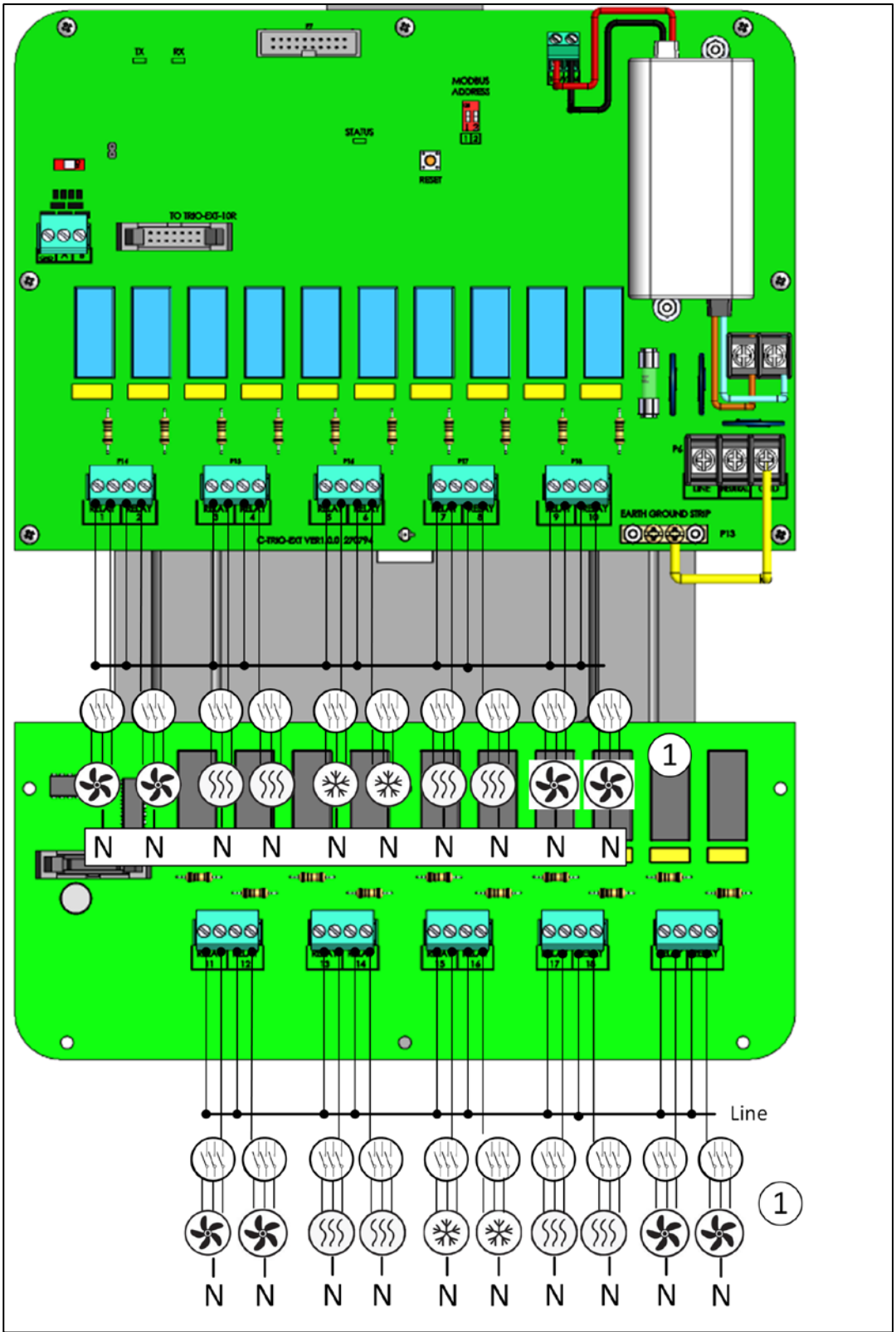

Figure 58: High voltage devices (examples)

1	Example of devices
---	--------------------

NOTE The relays control motors and heating devices via contactors, not directly.

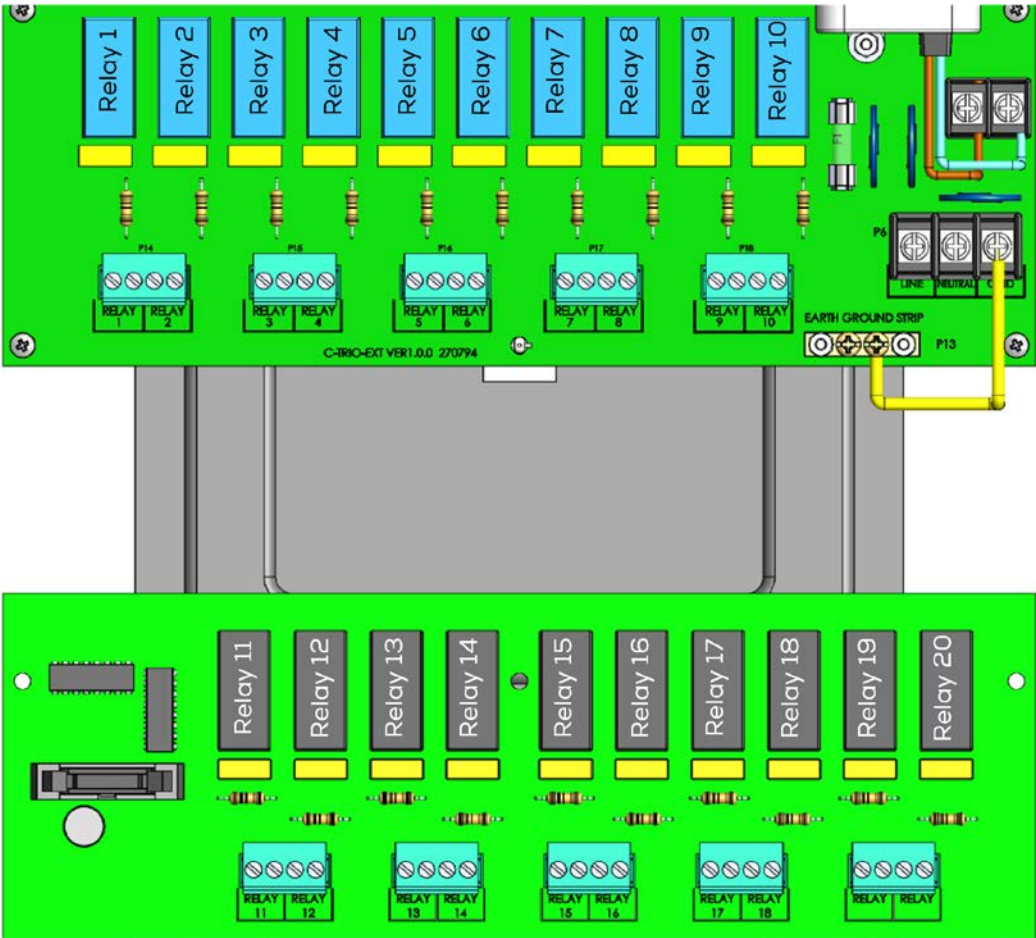

Figure 59: Relay and port numbering

### 11.3.4 POWER

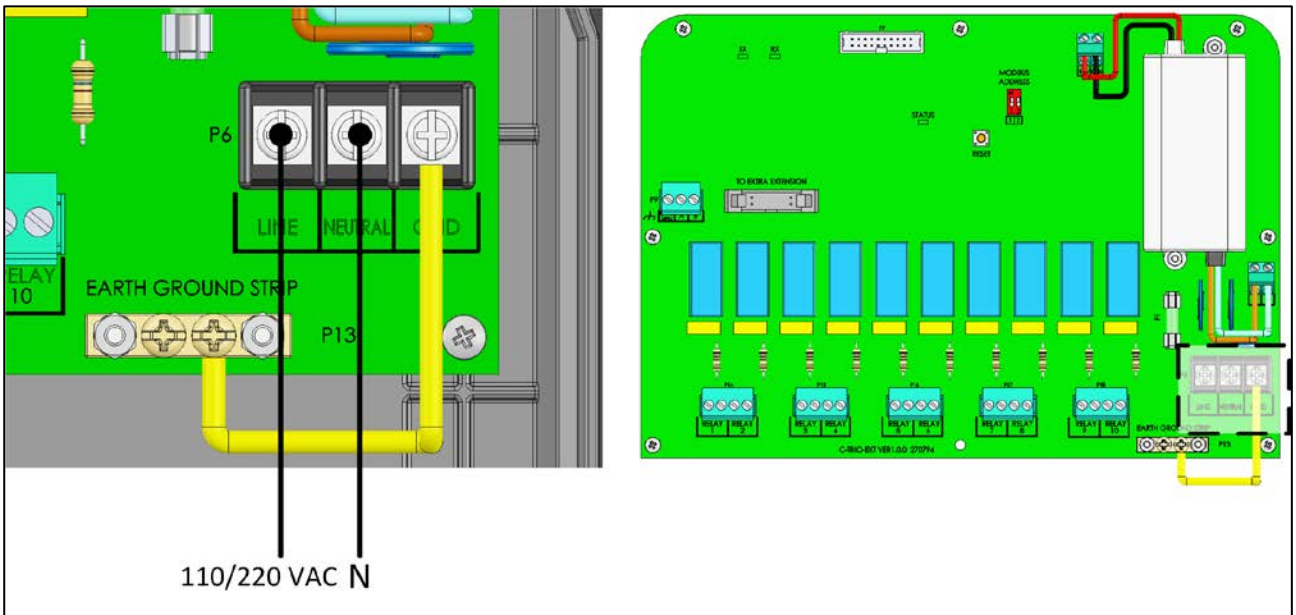

Figure 60: Power ports

### 11.4 Mapping Devices in Expansion

- Install and wire the Expansion unit to the TRIO and to the external devices before beginning.

- After wiring the Expansion unit to TRIO, go to System > General Settings > Info 



and click **Reset Factory Settings**. Follow the online instructions. TRIO will not recognize the Expansion until this step is performed.

After wiring devices to the TRIO Expansion Unit, each device must be mapped and then defined. Mapping and defining devices enables the system software to control each device's functionality.

**CAUTION** Mapping *MUST* match the physical wiring! An error message appears if the physical device is not wired to the relay or port as defined on the mapping screen.

To map the devices:

1. Go to System > Device and Sensors.

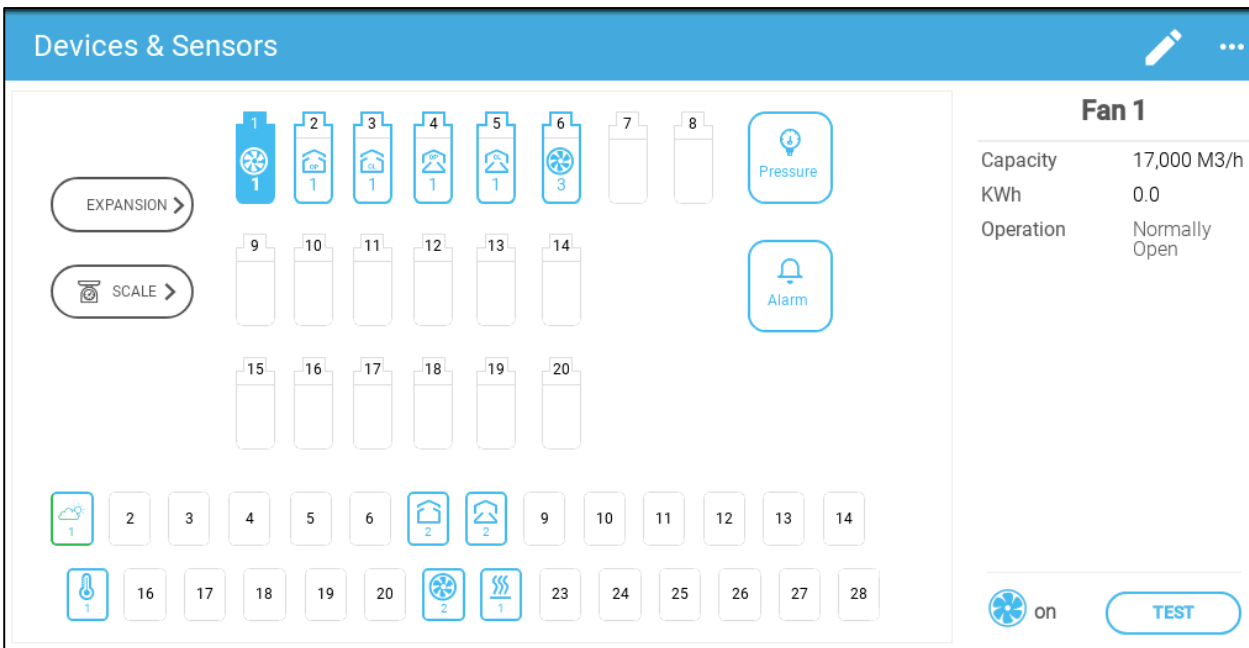

2. Click Expansion.

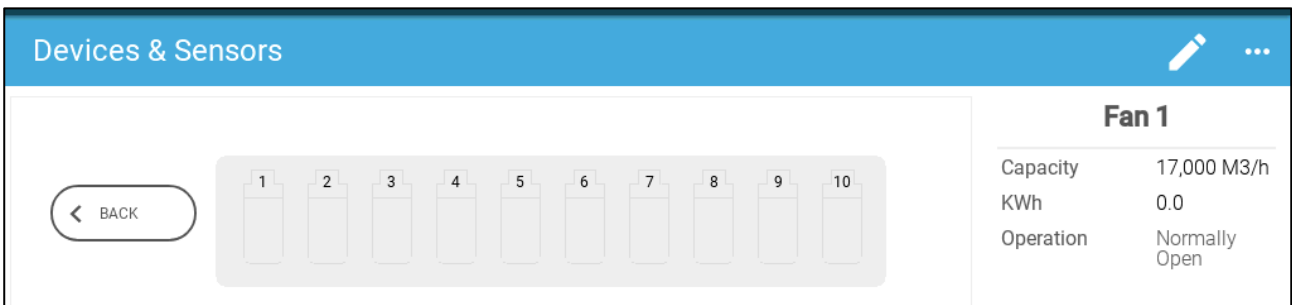





3. Map the devices as detailed in the TRIO manual. Refer to Using the Mapping , page 65 for more information.





## 11.5 Expansion Specifications

- Expansion 10 Specifications
- Expansion 20 Specifications
- Expansion Specification Details

### 11.5.1 EXPANSION 10 SPECIFICATIONS

Parameter	Specifications
Input Power Voltage	115/230 VAC, 50/60 Hz
Input AC Power	0.2A
Maximum number of relays operating simultaneously	10
<i>Note: Running relays at the above current levels provides between 50,000 – 100,000 switching operations.</i>	
Communication	RS-485: 115 Kbps, 8 bit, even parity
Operating Temperature Range	-10° to +50° C (+14° to +125° F)
Storage Temperature Range	-20° to +80° C (-4° to +176° F)
Environmental Specifications	<ul style="list-style-type: none"> <li>• Altitude: -400 m to 2000 m</li> <li>• Relative Humidity: 20% - 90%</li> <li>• Main supply voltage fluctuation up to +10 - 20%</li> <li>• Overvoltage category II</li> </ul>
Enclosure	<ul style="list-style-type: none"> <li>• Water and dust tight</li> <li>• Indoor use only</li> </ul>
Dimensions (H/W/D)	403 x 324 x 141 mm/16 x 13 x 5.6 inches
Fuses	Fuse F2 on PS card: 3.15A, 250V
Certification	   

### 11.5.2 EXPANSION 20 SPECIFICATIONS

Parameter	Specifications
Input Power Voltage	115/230 VAC, 50/60 Hz
Input AC Power	500 mA
Maximum number of relays operating simultaneously	15
<i>Note: Running relays at the above current levels provides between 50,000 – 100,000 switching operations.</i>	
Communication	RS-485: 115 Kbps, 8 bit, even parity
Operating Temperature Range	-10° to +50° C (+14° to +125° F)
Storage Temperature Range	-20° to +80° C (-4° to +176° F)
Environmental Specifications	<ul style="list-style-type: none"> <li>• Altitude: -400 m to 2000 m</li> <li>• Relative Humidity: 20% - 90%</li> <li>• Main supply voltage fluctuation up to +10 - 20%</li> <li>• Overvoltage category II</li> <li>• PD: 2</li> </ul>
Enclosure	<ul style="list-style-type: none"> <li>• IP: 52</li> <li>• Indoor use only</li> </ul>
Dimensions (H/W/D)	403 x 324 x 141 mm/16 x 13 x 5.6 inches
Fuses	Fuse F2 on PS card: 3.15A, 250V
Certification	   

### 11.5.3 EXPANSION SPECIFICATION DETAILS

- **Disconnection device/overcurrent protection:** In the building installation, use a certified 2-pole circuit breaker rated 10A, certified in accordance with the IEC standard 60947-2 (in the US and Canada use a Listed Branch Circuit protective circuit breaker). This step is required to provide overcurrent protection and mains disconnection. The circuit breaker must be easily accessible and marked as the controller disconnect device.
- **Main Supply Voltage:** Permanently connect the controller to the mains in accordance with the relevant national code. Provide fixed wiring inside a flexible conduit. Relays must be suitably protected against overcurrent, using a circuit breaker rated at 10A.
- **Keep the units closed and locked.** Only authorized personnel should open and close the units.

## 11.6 Expansion Spare Parts

- Preliminary Information
- Trio Expansion 10 Spare Parts
- Trio Expansion 20 Spare Parts
- Additional Options
- Cards

### 11.6.1 PRELIMINARY INFORMATION

	TRIO EXP 10	TRIO EXP 20
Container	<b>A</b>	<b>C</b>
Main Container Cards	<b>B</b>	<b>D</b>
Cables and Harnesses	<b>N/A</b>	<b>E</b>
MPN	Munters Part Number	
DPN	Distributor Part Number	

### 11.6.2 TRIO EXPANSION 10 SPARE PARTS

- Trio Expansion 10 Container Spare Parts
- Trio Expansion 10 Main Container Spare Parts

### 11.6.2.1 Trio Expansion 10 Container Spare Parts

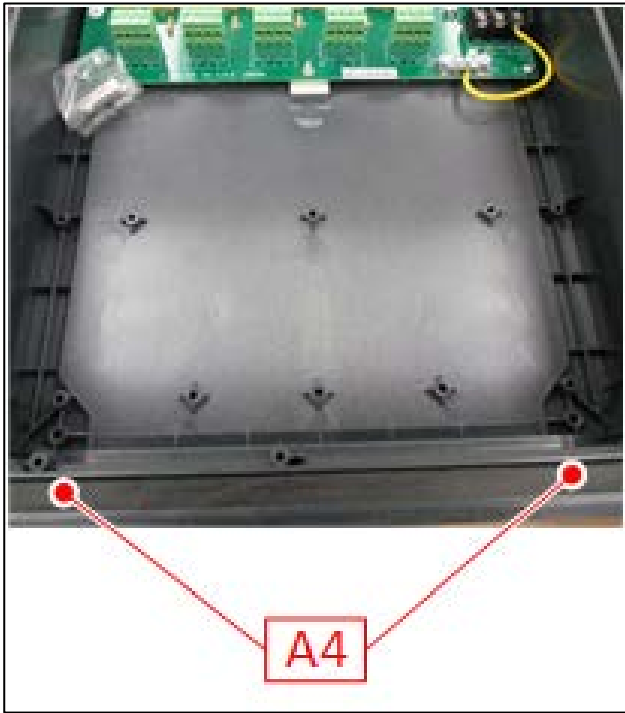

ID No.	Description	Catalog Number	Note
<b>A1.1</b>	TRIO FRONT DOOR EXP PLASTIC PART V1.0.0 (SP: 207129)	MPN: 940-99-00028 DPN:	
<b>A1.2</b>	TRIO-20 PLASTIC BOX BASE (SP: 207124)	MPN: 940-99-00112 DPN:	
<b>A1.3</b>	TRIO HINGE PLASTIC PIN V1.0.0 (SP-207128)	MPN: 940-99-00019 DPN:	
<b>A2.1</b>	TRIO-20 PANEL PLASTIC PART BLUE LOGO MUNTERS + PART BLUE	MPN: 940-99-00001 DPN:	OR
<b>A2.2</b>	TRIO PANEL PLASTIC PART RED RAL 3020 NO LOGO (SP-207138)	MPN: 940-99-00045 DPN:	
<b>A3.1</b>	GENERAL PLASTIC LATCH	MPN: 900-99-00216 DPN:	
<b>A3.2</b>	ONE/ONE PRO LATCH GENERAL LOCK PLASTIC PART + LOCK FOR LATCH	MPN: 900-99-00217 DPN:	
<b>A4</b>	MID-RANGE MAIN GASKET V1.0.0 (SP-207122)	MPN: 940-99-00021 DPN:	

### 11.6.2.2 Trio Expansion 10 Main Container Spare Parts

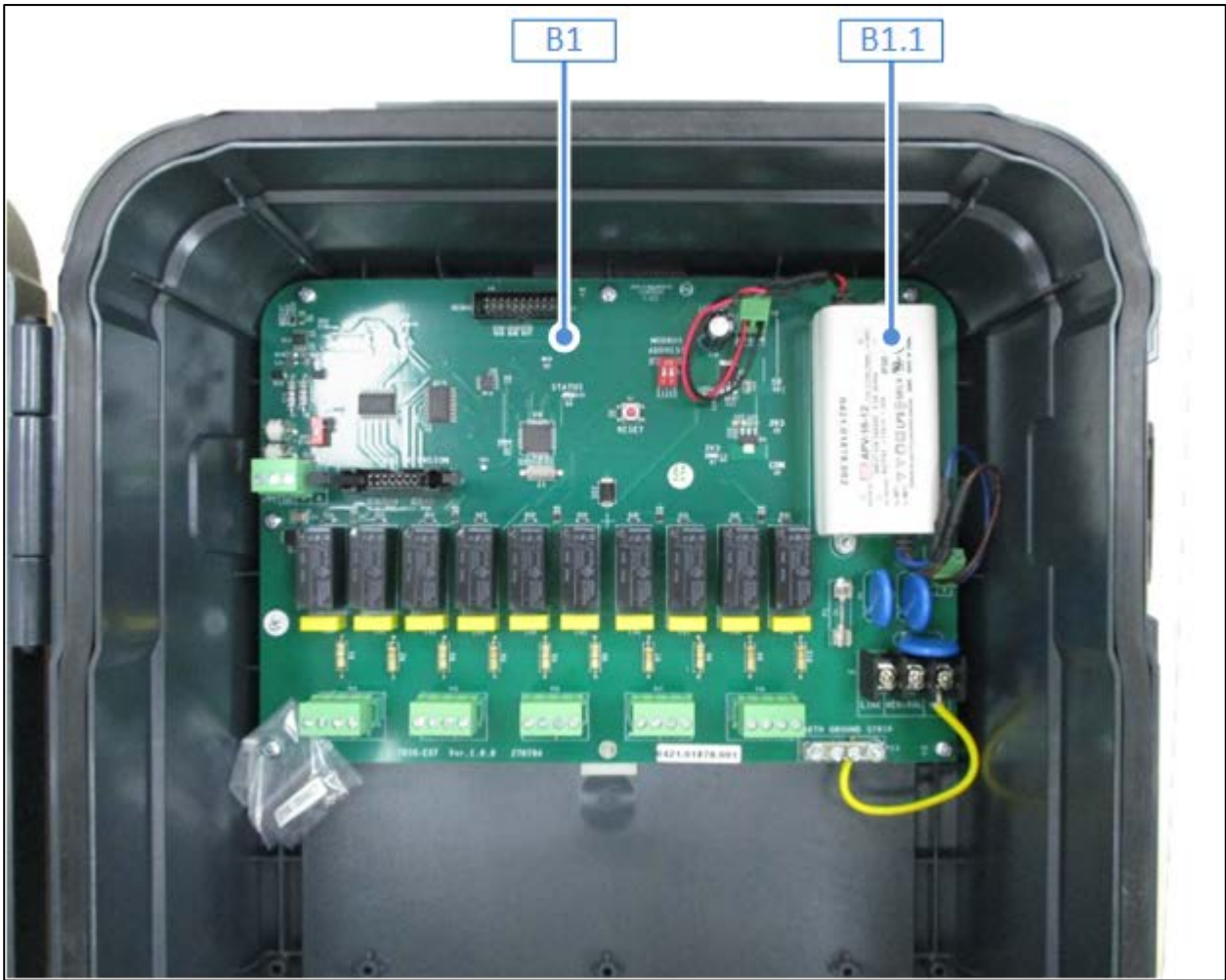

ID No.	Description	Catalog Number
<b>B1</b>	TRIO-EXP 10 CARD (SP: R-TRIO-EXP10)	MPN: 940-99-00029
		DPN:
<b>B1.1</b>	SWPS APV-16-12 Mean Well 115V/230V 12V 16W (SP: 370153)	MPN: 999-99-00338
		DPN:

### 11.6.3 TRIO EXPANSION 20 SPARE PARTS

- Trio Expansion 20 Container Spare Parts
- Trio Expansion 20 Main Container Spare Parts

### 11.6.3.1 Trio Expansion 20 Container Spare Parts

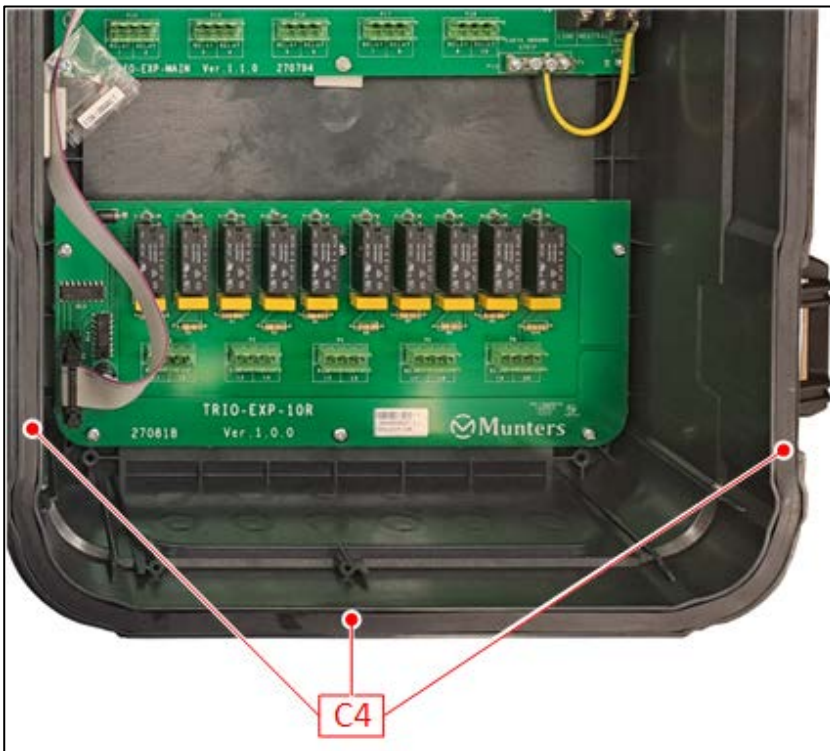

ID No.	Description	Catalog Number	Note
<b>C1.1</b>	TRIO FRONT DOOR EXP PLASTIC PART V1.0.0 (SP: 207129)	MPN: 940-99-00028 DPN:	
<b>C1.2</b>	TRIO-20 PLASTIC BOX BASE (SP: 207124)	MPN: 940-99-00112 DPN:	
<b>C1.3</b>	TRIO HINGE PLASTIC PIN V1.0.0 (SP-207128)	MPN: 940-99-00019 DPN:	
<b>C2.1</b>	TRIO-20 PANEL PLASTIC PART BLUE LOGO MUNTERS + PART BLUE	MPN: 940-99-00001 DPN:	OR
<b>C2.2</b>	TRIO PANEL PLASTIC PART RED RAL 3020 NO LOGO (SP-207138)	MPN: 940-99-00045 DPN:	
<b>C3.1</b>	GENERAL PLASTIC LATCH	MPN: 900-99-00216 DPN:	
<b>C3.2</b>	ONE/ONE PRO LATCH GENERAL LOCK PLASTIC PART + LOCK FOR LATCH	MPN: 900-99-00217 DPN:	
<b>C4</b>	MID-RANGE MAIN GASKET V1.0.0 (SP-207122)	MPN: 940-99-00021 DPN:	

### 11.6.3.2 Trio Expansion 20 Main Container Spare Parts

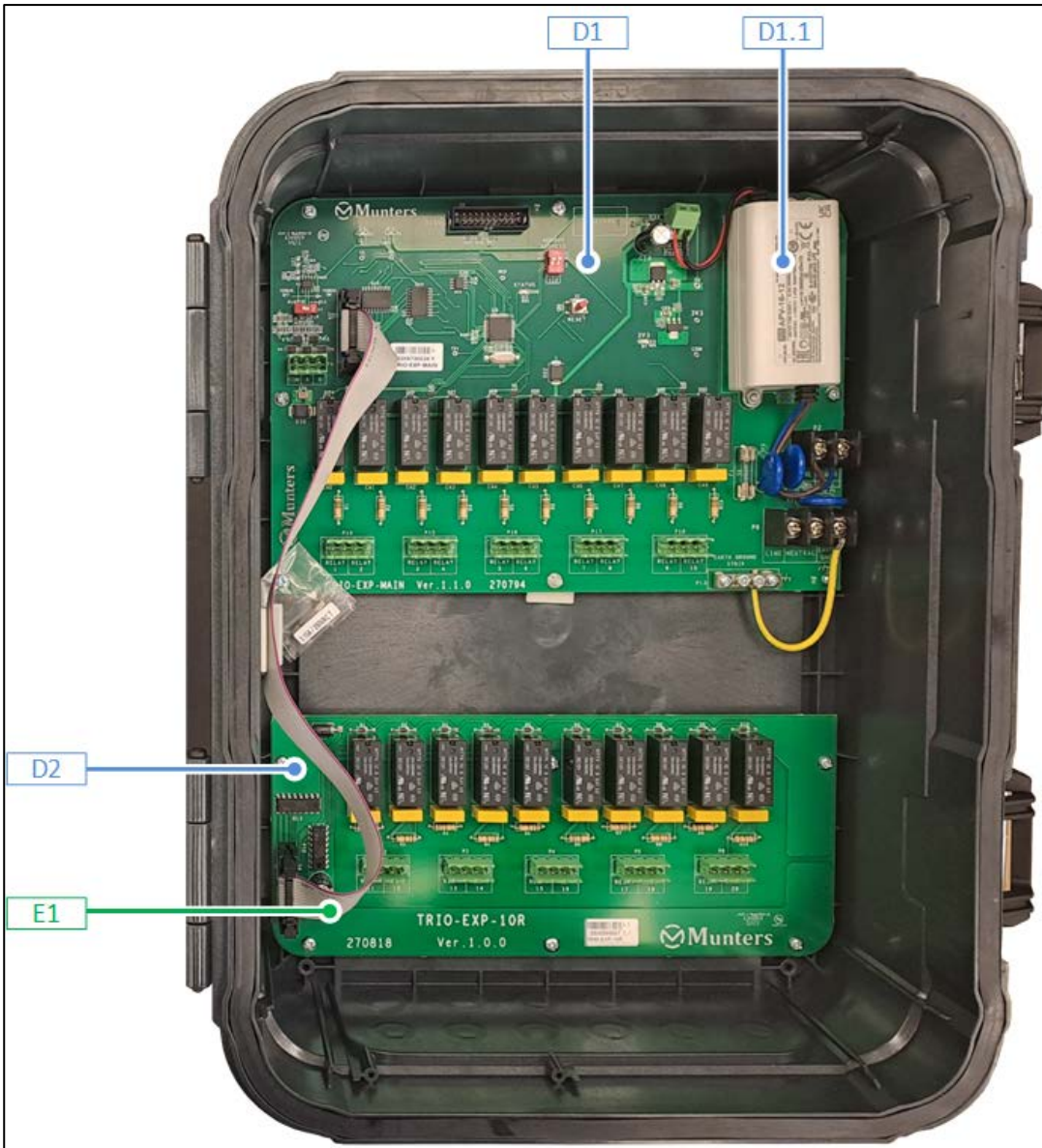



ID No.	Description	Catalog Number
D1	TRIO-EXP 10 CARD (SP: R-TRIO-EXP10)	MPN: 940-99-00029 DPN:
D1.1	SWPS APV-16-12 Mean Well 115V/230V 12V 16W (SP: 370153)	MPN: 999-99-00338 DPN:
D2	TRIO EXP 10 RELAY ADDIT CARD (TRIO-EXP-10R)	MPN: 940-99-00159 DPN:

ID No.	Description	Catalog Number
E1	FLAT FF14P 34cm (TRIO EXP)<F"D_F"D> (SP-141201)	MPN: 940-99-00168 DPN:

### 11.6.4 ADDITIONAL OPTIONS

ID No.	Description	Catalog Number
ADO 1	Trio Expansion: 10 Relays To 20 Relays Upgrade Kit	MPN: 940-99-00169
		DPN:

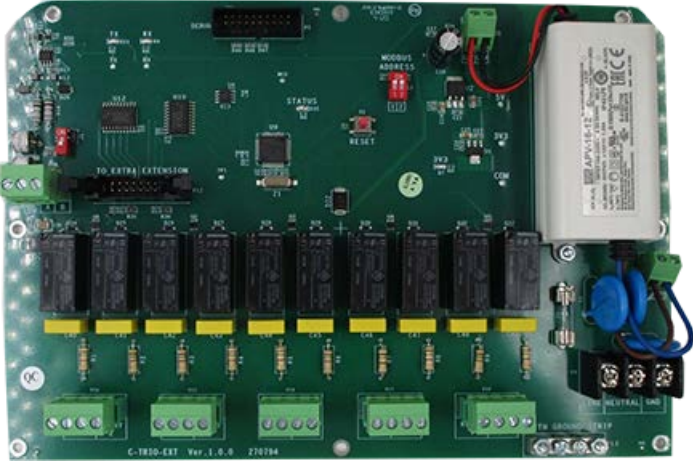
### 11.6.5 CARDS

Card	Description	Catalog Number
 <p>A green printed circuit board (PCB) for a Trio expansion. It features a central microcontroller, various status LEDs, a 'RESET' button, and a 'TO EXTRA EXTENSION' connector. The board is populated with several integrated circuits and has a 'C-TRIO-EXT Ver. 1.0.0 270794' label at the bottom.</p>	R-TRIO-EXP10: TRIO EXP 10 CARD	940-99-00029
 <p>A white Mean Well APV-16-12 switching power supply. It has a rectangular shape with a label that includes technical specifications: 'INPUT: 180-240V ~ 0.5A 50/60Hz SELV', 'OUTPUT: 12VDC 1.33A 16W', and 'IP42 LPS'. It has two sets of wires (red and black) for output and two for input.</p>	370153: SWPS APV-16-12 Mean Well 115V/230V 12V 16W	999-99-00338
 <p>A green PCB for a Trio expansion with 10 relays. It features ten relay modules arranged in a row, each with a 'RELAY' label and terminal numbers. The board includes a 'TRIO-EXP-10R' label, '270818 Ver. 1.0.0', and the Munters logo.</p>	R-TRIO-EXP- 10R: CARD EXP RLY ADDIT 10 TRIO	940-99-00159

# 12 Appendix E: IT Setup

The following information is intended for the IT specialist/ISP personnel setting up the internet LAN network between the Communicator 2.0 and Trio Controllers.

- IT Setup
- Subnet Setup
- LAN Cable Information

## 12.1 IT Setup

- Communicator 2.0 for Trio and Trio controllers must be on same subnet LAN.

**WARNING!** *In order to ensure continual communication, the Communicator 2.0 and Trio LAN must be an independent dedicated subnet.*

- Employ a standard home router, using the default settings, and all devices on the same router.
- On the local network, Communicator 2.0 and Trio must have same the subnet mask (subnet mask must be **255.255.255.0**).
- Three first sections of the Communicator 2.0 and Trio IP address must have the same numbers (for example **192.168.1.x**).
- Network must be IPv4.

**NOTE** *Munters recommends have a dedicated subnet for the Communicator 2.0/Trio network.*

- The local network can employ a firewall on condition that the following ports are open:
  - Zero-configuration networking (zeroconf)
  - RabbitMQ
  - MQTT
  - AMQP
  - 15672
  - 1883
  - 4200
  - UDP port 5353
  - UDP port 1900
  - TCP port 3689
  - 5355
  - 1883 MQTT
- Communicator 2.0 has a built-in firewall; all outgoing ports are closed. Incoming ports 8- and 443 are open.

## 12.2 Subnet Setup

To create a subnet within an industrial network that uses its own DHCP server with the range 192.168.1.1 - 192.168.1.255 or 192.168.2.1 - 192.168.2.255, you need networking equipment capable of isolating and managing traffic.

- Required Equipment
- Procedure

**CAUTION** Only Communicator 2.0 for Trio and Trio Controllers can be part of this subnet.

### 12.2.1 REQUIRED EQUIPMENT

- Router or Layer 3 Switch:
  - Capable of creating and managing subnets
  - Allows routing between subnets if required
  - Example: Cisco ISR, Ubiquiti EdgeRouter, or MikroTik
- Managed Switch (Optional):
  - If you need to segment traffic further with VLANs
  - Example: Cisco Catalyst, TP-Link JetStream, or similar
- DHCP Server or Router with DHCP Capabilities:
  - Configure a separate DHCP scope for the new subnet
  - Many modern routers support multiple DHCP scopes
- Firewall (Optional, for added security):
  - To enforce rules between the industrial network and the new subnet

### 12.2.2 PROCEDURE

1. Define the Subnet:
  - Choose a new IP range (e.g., 192.168.2.0/24)
2. Set Up the Router:
  - Configure a new interface or sub-interface for the new subnet
  - Assign an IP address (e.g., 192.168.2.1) to this interface
3. Configure DHCP for the New Subnet:
  - On the router or a dedicated DHCP server, set a DHCP scope (e.g., 192.168.2.2 - 192.168.2.254)
4. Isolate Traffic:
  - Ensure the industrial network (192.168.1.0/24) and the new subnet (e.g., 192.168.2.0/24) are isolated
  - Use VLANs or routing rules to control traffic flow
5. Connect Devices:
  - Connect devices in the new subnet to the appropriate port on the router/switch

## 12.3 LAN Cable Information

- Wire/Optical Ethernet Infrastructure Basics
- Trio Connectivity: 100/1000 GBPS Ethernet Switch

### 12.3.1 WIRE/OPTICAL ETHERNET INFRASTRUCTURE BASICS

- Wire Ethernet 1100/1000 BaseT Copper
  - Media – CAT5E or CAT6 Cable with maximum segment length of 100 meters
- Optical Ethernet 1000Base-X Optical
  - 1000Base-SX Media: Short Haul multi-mode optic fiber (MMF) with maximum segment length of 220 meters (62.5/125µm type) or 550 meters (50/125µm type)
  - 1000Base-LX Media: Long Haul single-mode optic fiber (SMF) with maximum segment length of 10000 meters
- Connectivity
  - Connectivity is Point-to-Point using 100/1000 Switches
  - Low latency network. If the DHCP takes too long (over 3 minutes) to assign IP addresses to controls, it may cause lost communication alarms when controls reset.
- Equipment
  - Wire Switch serves for Ethernet switching over wire connectivity
    - Could be with preinstalled specific Optic Transceiver (short or long haul)
    - Could be with the SFP port, serving for pluggable SFP Optic Transceiver
  - SFP Transceiver pluggable device serving to transmit data over optic fiber
    - 1000Base-SX SFP serves for multi-mode optic fiber (MMF) of
    - 62.5/125µm type or 50/125µm type
    - 1000Base-LX SFP serves for single-mode optic fiber (SMF)
  - Media Converters server for converting from optics to wire and vice versa. This is used for segments over 100 meters / 330 feet.

### 12.3.2 TRIO CONNECTIVITY: 100/1000 GBPS ETHERNET SWITCH

- The switch is wired to the router and modem to access the Internet.
- Switches can be wired to each other by Ethernet cables, each one splitting off to other devices.
- Gigabit switches support 100 and 1,000 Mbps

## 12.4 Typical Setup

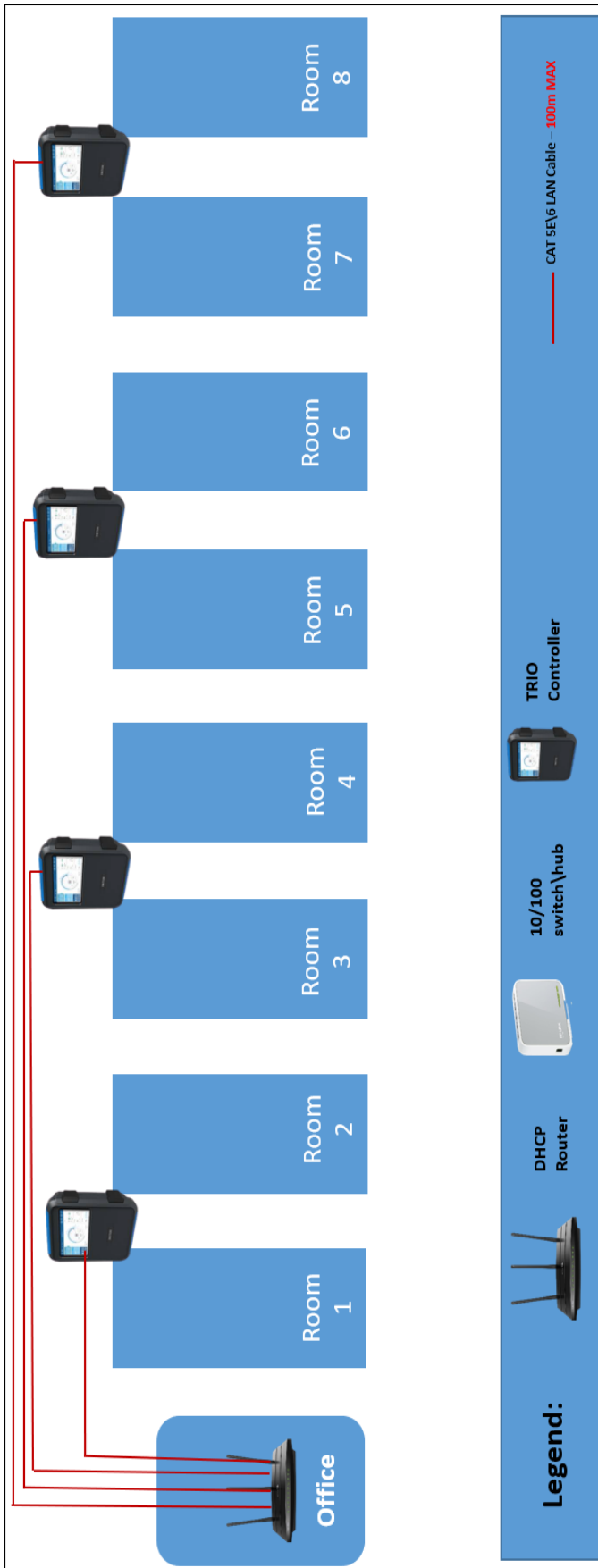

Figure 61: Typical Swine Installation

# 13 Index

3V Battery		LAN Cable .....	151
Location .....	29, 30	Equipment .....	151
Alarm Battery		SFP Transceiver .....	151
Restart .....	104	Wire Switch .....	151
Ventilation .....	104	Latency .....	151
Ammonia Sensor		Media .....	151
Wiring .....	45	Optic Fiber .....	151
Analog Out Devices		Switches .....	151
Wiring .....	35	Mapping .....	65
authorized electrician .....	16	Devices .....	66
Board layout		Error Message .....	65
Version 1.1.0 .....	29	Sensors .....	66
Board Layout		Modem .....	29, 30
Version 1.0.4 .....	30	Potentiometer	
Bracket .....	26, 27	Schematic .....	44
Cable		Wiring .....	44
Ethernet .....	27	Power Loss .....	104
Cables		SMS .....	104
Routing .....	26	Relay	
Communicator 2.0 .....	149	Alarm .....	33
Digital Devices		Relays	
Wiring .....	36	Numbering .....	32
Dipswitches .....	28	RHS	
electrical shock .....	16	Schematic .....	43
electrician .....	16	Wiring .....	42
Ethernet Port .....	30	RPLP-1 .....	13
Location .....	34	RPS	
Firewall .....	149, 150	Schematic .....	47
Heat Sink .....	29	Static Pressure Tubes .....	48
Icon		Wiring .....	47
3V Battery .....	63	RTC Batteries .....	28
Delete Data .....	63	RTS-2 .....	26
Edit Parameters .....	63	S Port Schematic .....	41
Settings .....	63	S Port Wiring .....	41
Installation		Wiring .....	40
Inverter .....	15	RTV .....	27
Keys .....	24, 26	SD Port .....	29, 30

sealant .....	27	Average.....	70
shock .....	16	Device.....	70
silicon .....	27	Outside.....	70
SIM Port.....	30	Tunnel .....	70
Subnet		Trio	
DHCP Server .....	150	Static Pressure Tubes.....	53
Router/Switch .....	150	Wireless Antenna .....	29
Subnet Mask .....	149	Wiring	
Symbols		Analog Input Devices.....	37
Caution.....	25	Analog Output Devices .....	35
Earthing .....	25	CO2 Sensor .....	37
Hazardous voltage.....	25	Digital Devices.....	36
Temperature			

# 14 Warranty

## Warranty and technical assistance

Munters products are designed and built to provide reliable and satisfactory performance but cannot be guaranteed free of faults; although they are reliable products they can develop unforeseeable defects and the user must take this into account and arrange adequate emergency or alarm systems if failure to operate could cause damage to the articles for which the Munters plant was required: if this is not done, the user is fully responsible for the damage which they could suffer.

Munters extends this limited warranty to the first purchaser and guarantees its products to be free from defects originating in manufacture or materials for one year from the date of delivery, provided that suitable transport, storage, installation and maintenance terms are complied with. The warranty does not apply if the products have been repaired without express authorisation from Munters, or repaired in such a way that, in Munters' judgement, their performance and reliability have been impaired, or incorrectly installed, or subjected to improper use. The user accepts total responsibility for incorrect use of the products.

The warranty on products from outside suppliers fitted to TRIO, (for example antennas, power supplies, cables, etc.) is limited to the conditions stated by the supplier: all claims must be made in writing within eight days of the discovery of the defect and within 12 months of the delivery of the defective product. Munters has thirty days from the date of receipt in which to take action, and has the right to examine the product at the customer's premises or at its own plant (carriage cost to be borne by the customer).

Munters at its sole discretion has the option of replacing or repairing, free of charge, products which it considers defective, and will arrange for their despatch back to the customer carriage paid. In the case of faulty parts of small commercial value which are widely available (such as bolts, etc.) for urgent despatch, where the cost of carriage would exceed the value of the parts, Munters may authorise the customer exclusively to purchase the replacement parts locally; Munters will reimburse the value of the product at its cost price.

Munters will not be liable for costs incurred in demounting the defective part, or the time required to travel to site and the associated travel costs. No agent, employee or dealer is authorised to give any further guarantees or to accept any other liability on Munters' behalf in connection with other Munters products, except in writing with the signature of one of the Company's Managers.

**WARNING:** In the interests of improving the quality of its products and services, Munters reserves the right at any time and without prior notice to alter the specifications in this manual.

The liability of the manufacturer Munters ceases in the event of:

- dismantling the safety devices;

- use of unauthorised materials;
- inadequate maintenance;
- use of non-original spare parts and accessories.

Barring specific contractual terms, the following are directly at the user's expense:

- preparing installation sites;
- providing an electricity supply (including the protective equipotential bonding (PE) conductor, in accordance with CEI EN 60204-1, paragraph 8.2), for correctly connecting the equipment to the mains electricity supply;
- providing ancillary services appropriate to the requirements of the plant based on the information supplied with regard to installation;
- tools and consumables required for fitting and installation;
- lubricants necessary for commissioning and maintenance.

It is mandatory to purchase and use only original spare parts or those recommended by the manufacturer.

Dismantling and assembly must be performed by qualified technicians and according to the manufacturer's instructions.

The use of non-original spare parts or incorrect assembly exonerates the manufacturer from all liability.

Requests for technical assistance and spare parts can be made directly to the nearest [Munters office](#).

