

# Communicator 2.0 for Trio

## Installation and User Manual



# Communicator 2.0 for Trio

## Communication System

Ag/MIS/UmEn-2774-07/20 Rev 2.4

P/N: 116801



# Communicator 2.0 for Trio

## Manual for use and maintenance

Document Revision: 2.4, 05/2025

Software Ver: 1.1.13

This manual for use and maintenance is an integral part of the apparatus together with the attached technical documentation.

This document is destined for the user of the apparatus: it may not be reproduced in whole or in part, committed to computer memory as a file or delivered to third parties without the prior authorization of the assembler of the system.

Munters reserves the right to effect modifications to the apparatus in accordance with technical and legal developments.

# Index

<i>chapter</i>		<i>page</i>
<b>1</b>	<b>INTRODUCTION .....</b>	<b>5</b>
1.1	Disclaimer.....	5
1.2	Introduction .....	5
1.3	Notes .....	5
<b>2</b>	<b>INTRODUCTION TO THE COMMUNICATOR 2.0 .....</b>	<b>6</b>
<b>3</b>	<b>HARDWARE INSTALLATION .....</b>	<b>7</b>
3.1	Precautions .....	7
3.2	Communicator 2.0 Ports.....	8
3.3	Interior.....	9
3.4	Mounting the Communicator 2.0 .....	10
3.5	Grounding .....	11
3.6	Connecting the Communicator 2.0 to the Internet .....	11
3.7	Connecting the Communicator 2.0 to a Phone Line.....	12
3.8	Attaching the Antenna .....	12
3.9	Connecting the Communicator 2.0 to a Peripheral Device.....	12
3.10	Connecting the T-Box to External Devices.....	13
3.11	Setting Up a Communicator 2.0 / Trio LAN .....	14
3.12	Enabling SMS Messages .....	15
3.13	Testing the Battery.....	15
	3.13.1 Testing After Installation.....	15
	3.13.2 Periodic Testing.....	16
<b>4</b>	<b>SPECIFICATIONS .....</b>	<b>19</b>
<b>5</b>	<b>FUNCTIONALITY .....</b>	<b>20</b>
5.1	Farm Settings .....	20
5.2	Alarms.....	21
	5.2.1 Editing the Settings.....	22
	5.2.2 Adding Contacts .....	24
	5.2.3 Alarm and Events History.....	26
	5.2.4 Digital Inputs.....	27
	5.2.5 Disable Alarms .....	28
	5.2.6 Clear Alarms.....	28
5.3	Responding to Alarms.....	28
	5.3.1 Responding to an Audio Message.....	28
	5.3.1.1 Receiving the Message.....	29

5.3.1.2	Responding to the Alarm Message .....	29
5.3.2	Responding to a Text Message .....	30
5.3.2.1	Resetting the Siren .....	30
5.3.2.2	Resetting the Alarm .....	30
5.3.2.3	Acknowledging a Message .....	30
5.4	Testing the Communicator 2.0.....	31
5.5	Additional Functions .....	31
5.5.1	Software Upgrade .....	31
5.5.2	Battery Status .....	32
5.5.3	Controllers Connectivity .....	33
5.5.4	About Tab / Technical Support.....	34
<b>6</b>	<b>DIAGNOSTICS .....</b>	<b>35</b>
<b>7</b>	<b>APPENDIX A: CHANGING THE BATTERY .....</b>	<b>36</b>
<b>8</b>	<b>WARRANTY .....</b>	<b>38</b>

# 1 Introduction

## 1.1 Disclaimer

Munters reserves the right to make alterations to specifications, quantities, dimensions etc. for production or other reasons, subsequent to publication. The information contained herein has been prepared by qualified experts within Munters. While we believe the information is accurate and complete, we make no warranty or representation for any particular purposes. The information is offered in good faith and with the understanding that any use of the units or accessories in breach of the directions and warnings in this document is at the sole discretion and risk of the user.

## 1.2 Introduction

Congratulations on your excellent choice of purchasing a Trio Communicator 2.0!

In order to realize the full benefit from this product it is important that it is installed, commissioned and operated correctly. Before installation or using the Communicator 2.0, this manual should be studied carefully. It is also recommended that it is kept safely for future reference. The manual is intended as a reference for installation, commissioning and day-to-day operation of Munters equipment.

## 1.3 Notes

Date of release: October 2018

Munters cannot guarantee to inform users about the changes or to distribute new manuals to them.

All rights reserved. No part of this manual may be reproduced in any manner whatsoever without the expressed written permission of Munters. The contents of this manual are subject to change without notice.

# 2 Introduction to the Communicator 2.0

Communicator 2.0 provides complete access to your Munters Trio controllers, with alarms and events sent directly to your mobile device, PC, or tablet. From one computer, tablet, or smartphone, you can manage an entire network.

- Web and Cloud-based access to controllers
  - Multiple, simultaneous users have network access
- Multiple communication pathways:
  - Built-in internet and telephone connectivity
  - Cellular modem enables wireless communication
- Plug ins:
  - Cell modem according to the user's region (3G Worldwide, 4G US, 4G Worldwide)
  - Line modem

*NOTE Voice functions require a line modem.*

- Supports Munters' Web Application and Smart Phone Application
- Programmable alarms
  - Text messages sent in a variety of languages
  - Alarms and data in real time
- Test functions ensure the Communicator 2.0 works as required

# 3 Hardware Installation

This document details how to install Munters' Communicator 2.0 unit. Installation can include the following:

- Precautions
- Communicator 2.0 Ports
- Interior
- Mounting the Communicator 2.0
- Grounding
- Connecting the Communicator 2.0 to the Internet
- Connecting the Communicator 2.0 to a Phone Line
- Attaching the Antenna
- Connecting the Communicator 2.0 to a Peripheral Device
- Connecting the T-Box to External Devices
- Setting Up a Communicator 2.0 / Trio LAN
- Enabling SMS Messages
- Error! Reference source not found.

**NOTE:** *After installing the unit, check the Diagnostics (page 35) to make sure that everything is working as required.*

## 3.1 Precautions

Observe the following precautions when using your unit.

- Keep the Communicator 2.0 as far as possible from heavy contactor boxes and other sources of electrical interference.
- Do not connect communication wire shields, which go from one house to another at both ends. Connect them at one end only. Connection at both ends can cause ground loop currents to flow, which reduce reliability.
- The COM connection for communications is not the shield wire. The COM, RX and TX wires must connect to each other at all controllers.
- **The Communicator 2.0 and Trio units must have an independent subnet LAN. Refer to the Trio Installation Manual for detailed instructions on setting up a Communicator 2.0/Trio Network.**
- **Anyone wanting to install the M2 line modem must upgrade the power board to Version 1.F.0.0 or higher.**

### 3.2 Communicator 2.0 Ports

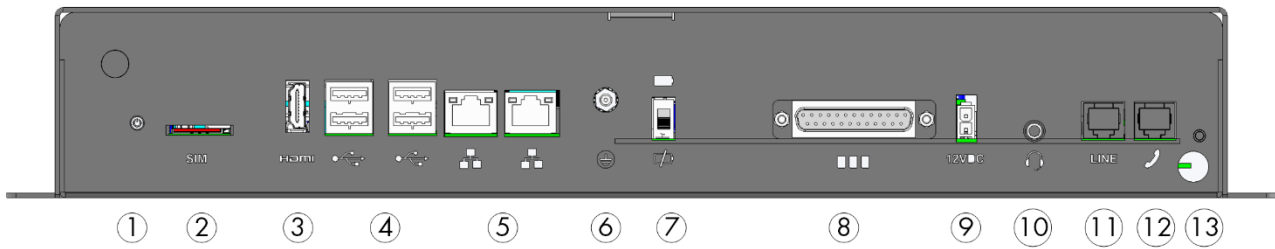

Figure 1: External Ports

Table 1: Ports Description

Number	Description	Number	Description
1	Antenna mounting port (refer to Attaching the Antenna, page 12)	8	25 pin connector (Not in use)
2	SIM card (internal cell modem) (refer to Enabling SMS Messages, page 15)	9	12 VDC
3	HDMI port (computer screen) (refer to Connecting the Communicator 2.0 to a Peripheral Device, page 12)	10	Audio out (external speaker)
4	USB ports (mouse, KBD) (refer to Connecting the Communicator 2.0 to a Peripheral Device, page 12)	11	Internet line port(refer to Connecting the Communicator 2.0 to the Internet, page 11)
5	LAN ports	12	Phone line port (refer to Connecting the Communicator 2.0 to a Phone Line, 12)
6	Grounding (refer to Grounding, page 11)	13	Power cord
7	Battery disconnection switch		

### 3.3 Interior

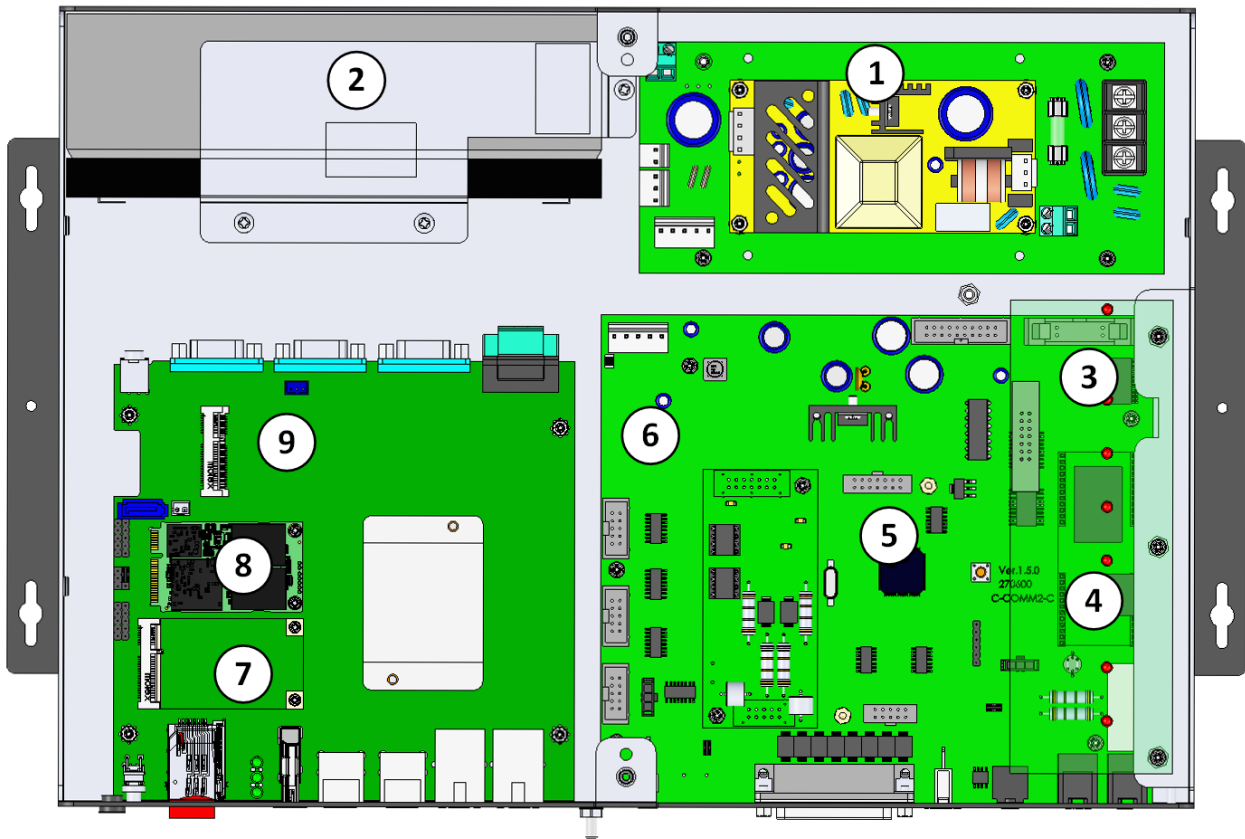

Figure 2: Components

Table 2: Component Description

Number	Description	Notes
1	Power Supply	
2	Battery (refer to Appendix A: Changing the Battery, page 36)	
3	LED Board	
4	Line Modem Card	This card is under the LED board
5	Not used	
6	Board	
7	Cell Modem	
8	SSD Card	
9	Main CPU	

### 3.4 Mounting the Communicator 2.0

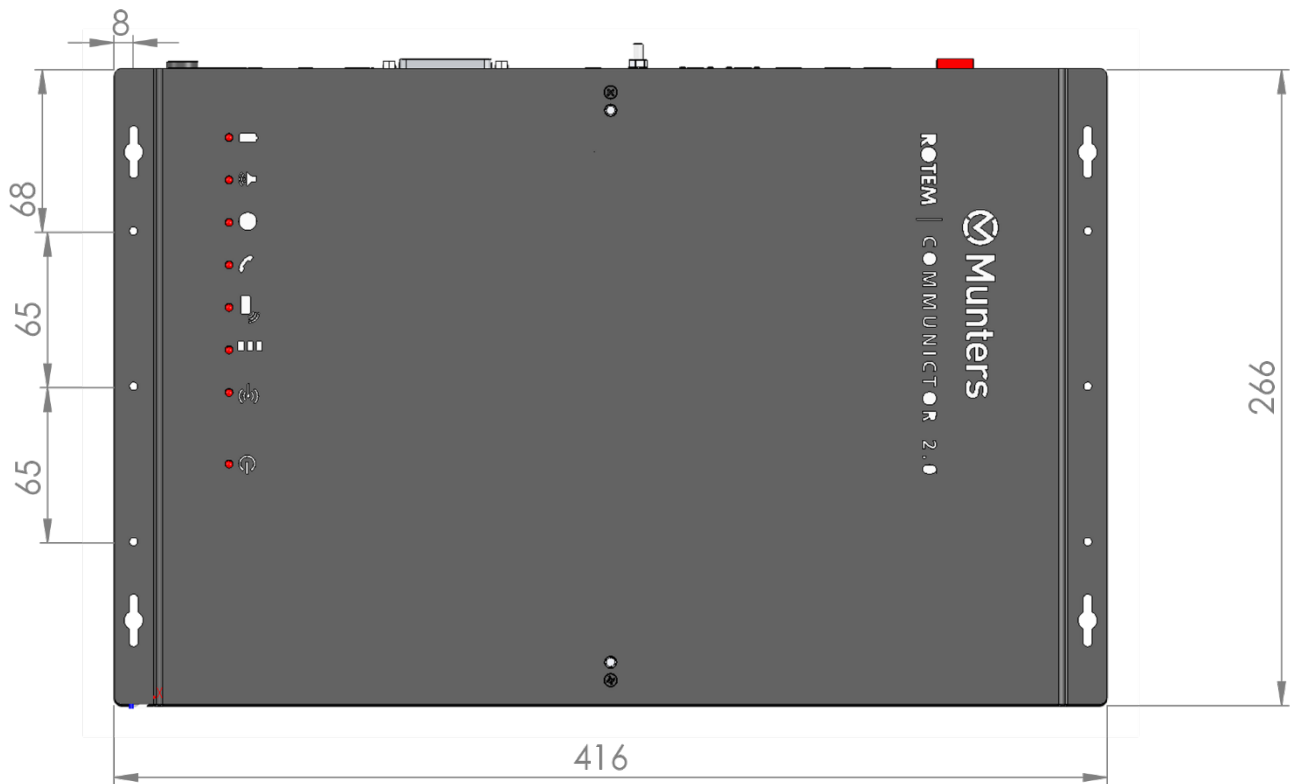

Figure 3: Dimensions (mm)

- Mount the unit using the four supplied screws.

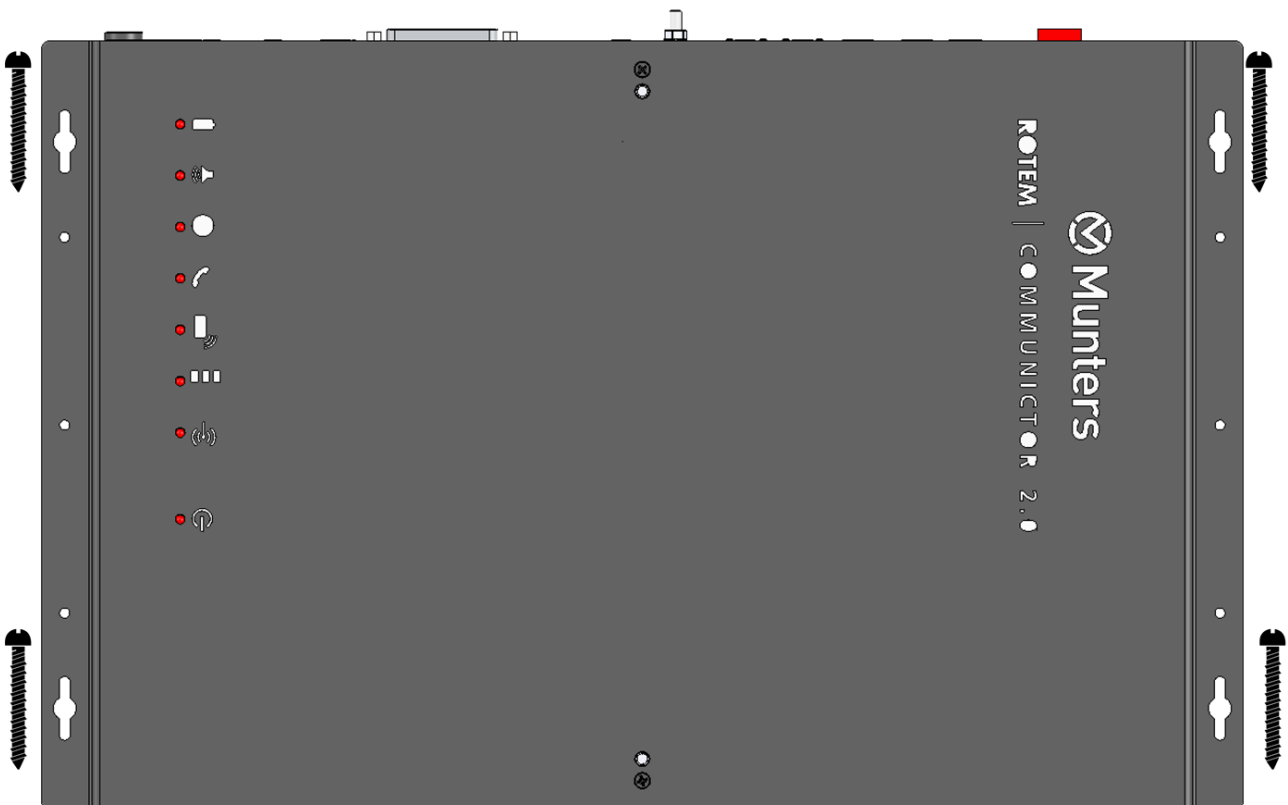

Figure 4: Mounting

### 3.5 Grounding

- Connect the ground cable to the dedicated ground terminal.

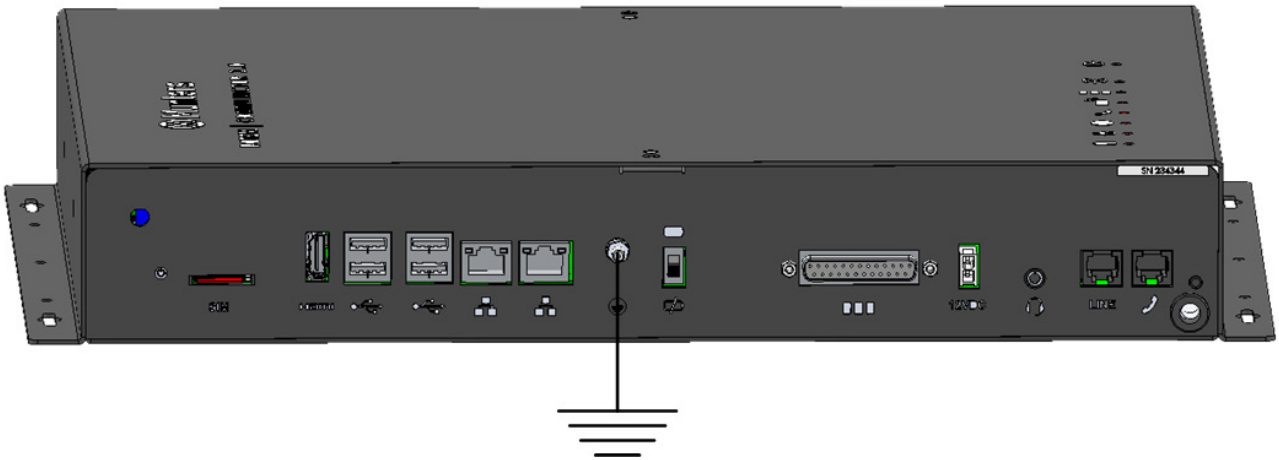

Figure 5: Grounding Schematic

**CAUTION** The Communicator 2.0 must be grounded at all times!

### 3.6 Connecting the Communicator 2.0 to the Internet

- Connect the Communicator 2.0 to your Internet connection.



Figure 6: Internet Connection

### 3.7 Connecting the Communicator 2.0 to a Phone Line



Figure 7: Phone Line Connection

**NOTE** The telephone line-modem output connection wiring must provide double insulation. Use minimum 26 AWG wiring or larger for telephone line connection.

### 3.8 Attaching the Antenna

If the Communicator 2.0 comes with a cell modem, attach the antenna.



Figure 8: Antenna Attachment

### 3.9 Connecting the Communicator 2.0 to a Peripheral Device

- If required, connect a screen and key board to the Communicator 2.0 (via the four USB or single HDMI ports).

**NOTE:** You'll need to connect the Communicator 2.0 to these devices for the Activation.

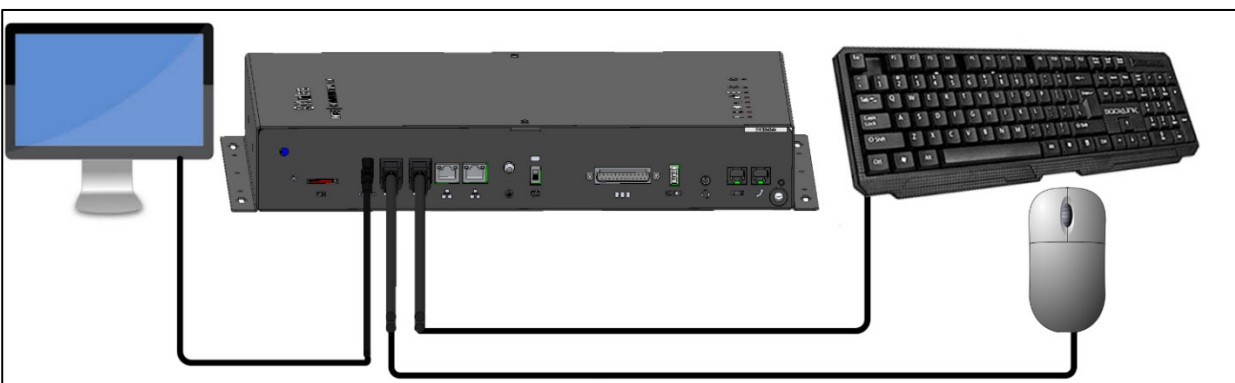

Figure 9: Connection to Peripherals

### 3.10 Connecting the T-Box to External Devices

If required, connect the T-Box to external devices and an ELS system (Figure 11).

1. Plug the 25 pin connector into the T-Box.

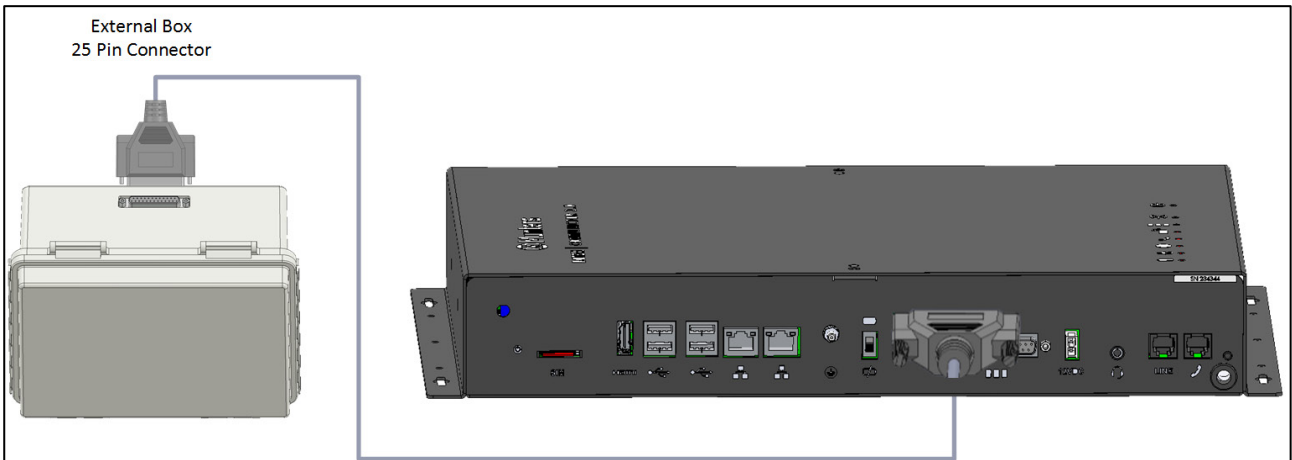

Figure 10: Communicator 2.0 – Junction Box – Controller Block Diagram

2. Wire the devices as shown in Figure 11.

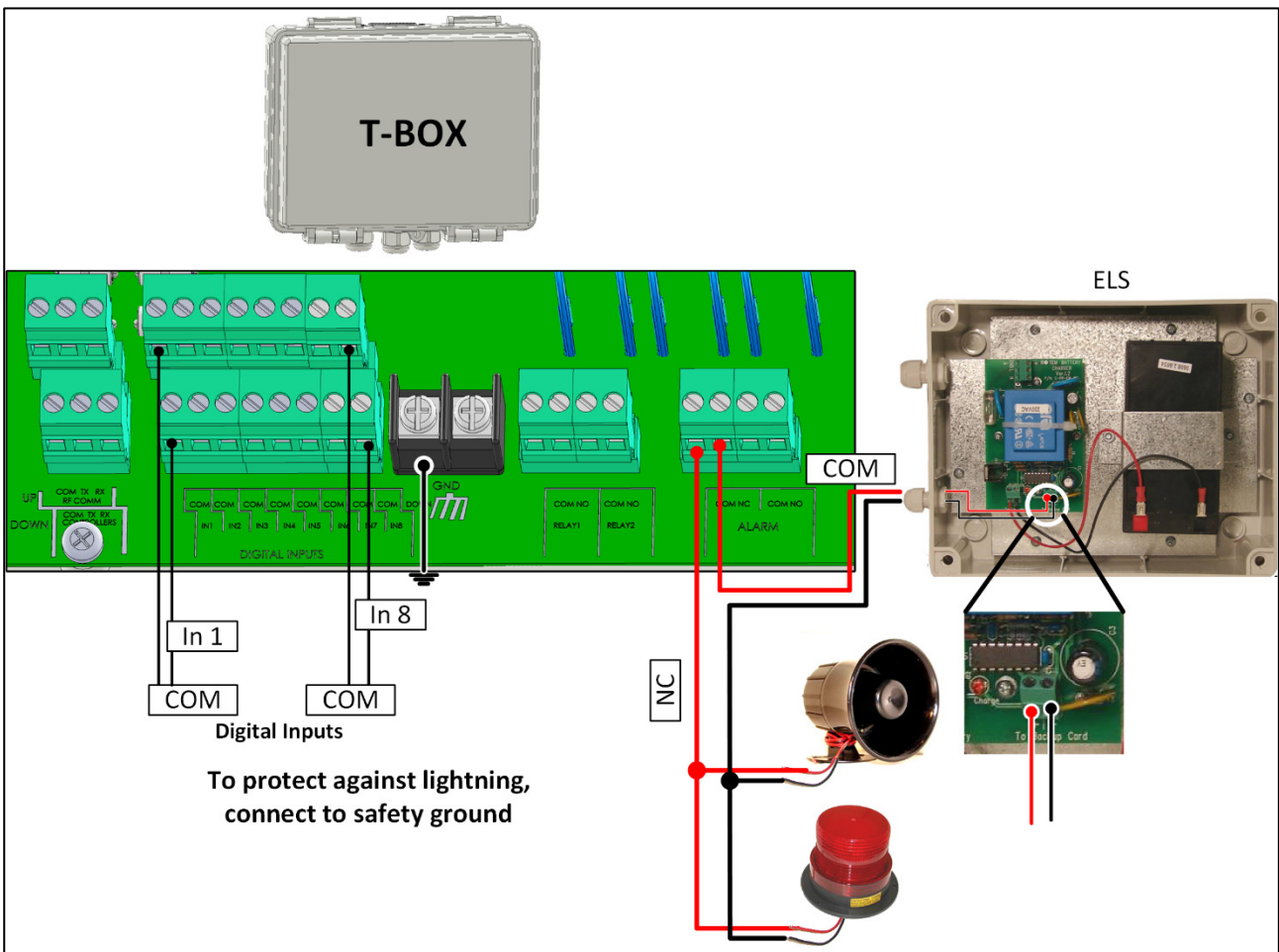
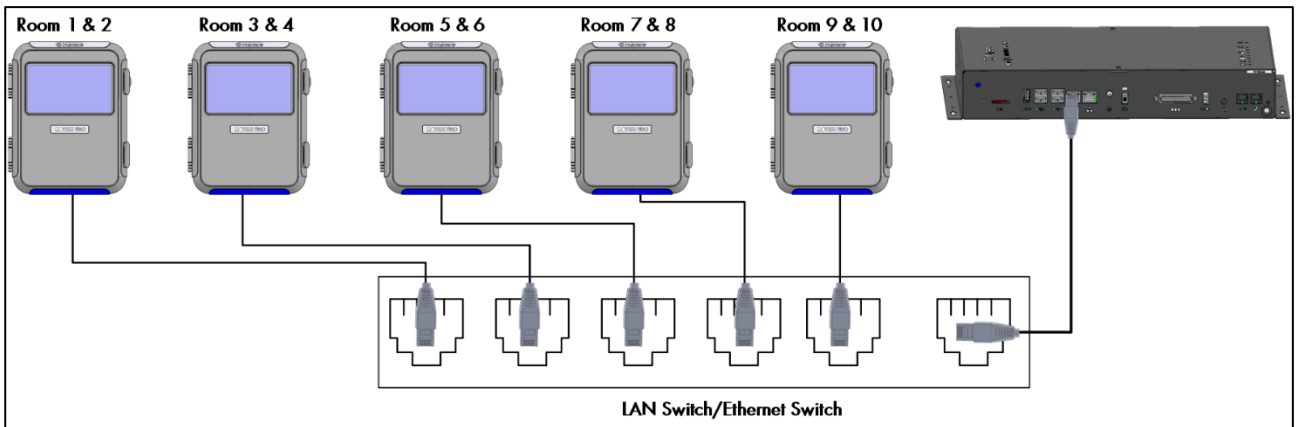

Figure 11: T-Box Wiring Diagram with ELS

### 3.11 Setting Up a Communicator 2.0 / Trio LAN

Connect the Communicator 2.0 and Trio units via a local intranet.



*NOTE The Communicator 2.0 and Trio units can be plugged into any port. The above drawing is an example only.*

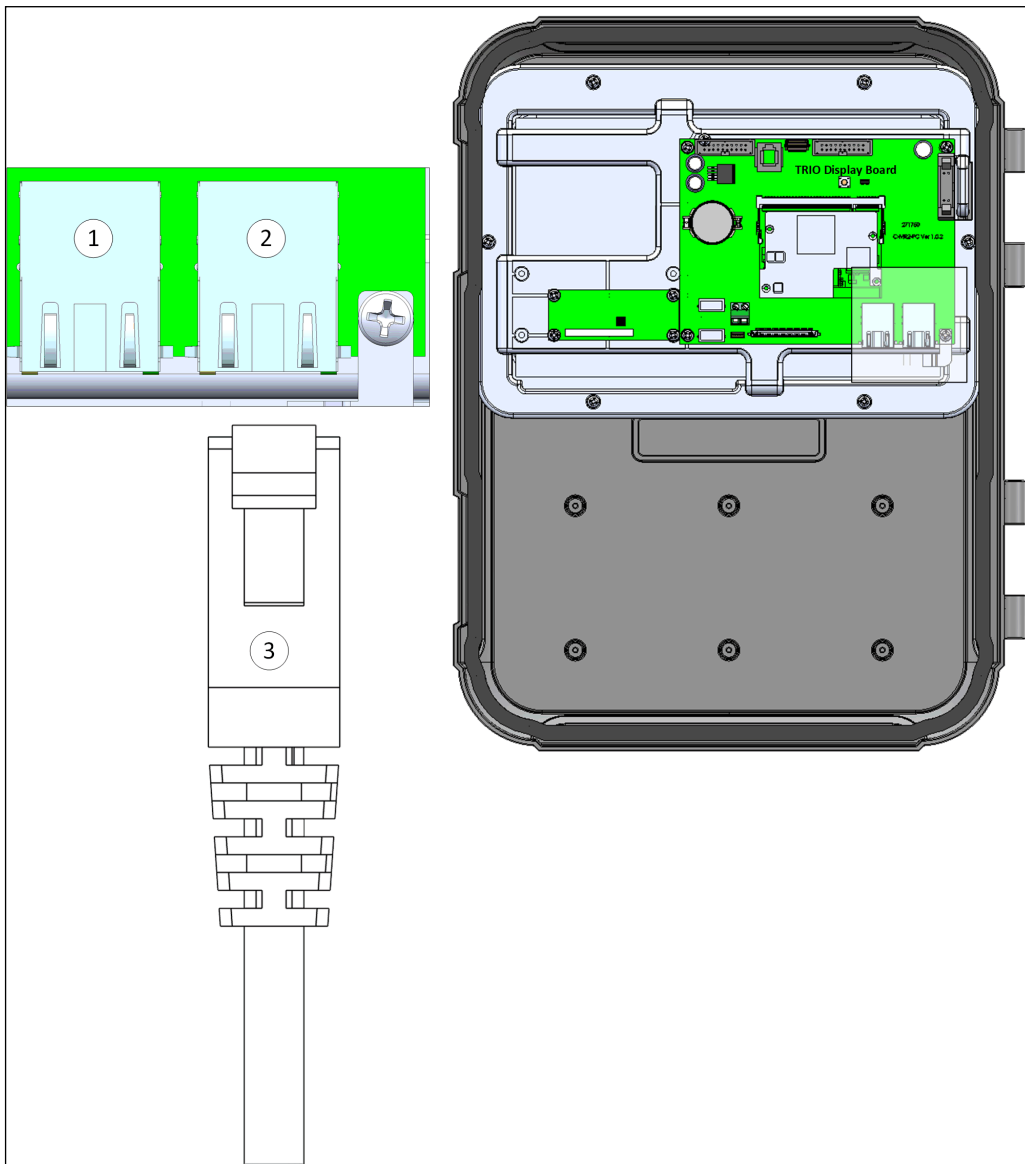

Figure 12: Trio Ethernet port

**CAUTION** Connect the intranet cable to port 2. Do not connect the cable to port 1.

1	Internal port (do not use this port)
2	Ethernet port
3	RJ-45 cable

### 3.12 Enabling SMS Messages

- Sending SMS message requires a Communicator 2.0 having an internal modem (supplied by Munters if ordered). This modem will support your cellular infrastructure and region (4G US, 4G ROW, 3G)
- Insert a 3G or 4G standard SIM card as indicated:



SIM Card

Figure 13: SIM Port

### 3.13 Testing the Battery

- Testing After Installation
- Periodic Testing

#### 3.13.1 TESTING AFTER INSTALLATION

**CAUTION** Munters highly recommends testing the battery immediately after completing the installation!

1. Ensure that the battery is charged (Green LED should be on continuously). If the LED blinks, wait.
2. Disconnect the AC power. The power LED turns off.
3. You should receive an alarm according to the contact list settings.
4. After receiving the alarm message, reapply power.

### 3.13.2 PERIODIC TESTING

The following procedure tests the battery's ability to hold a charge.

**CAUTION** Munters recommends testing the battery before each flock start.

1. Go to the Home screen > Alarm settings tab. The Power Management specifications display the relevant data.

The screenshot displays the Munters T9.Win32Comm interface. The top navigation bar includes the Munters logo, the device name 'T9.Win32Comm', and user information 'Farm Owner'. Below the navigation bar, there are several tabs: 'Comparison', 'Alarm Settings', 'Alarm Contacts', 'Alarm History', 'Event History', 'Digital Input', 'Disable Alarms', and 'Generators Settings'. The 'Alarm Settings' tab is active, showing various settings for 'House 1'. The 'About' section is visible, containing 'Connectivity', 'Cellular Signal', and 'Serial ID' information. A red box highlights the 'Power Management' section, which includes the following data:

Power Management	
Battery	Battery Installed
Last Test	5/15/2025 2:12:54 AM
Charge Currency (mA)	2.248723
Battery Voltage (V)	13.42
Battery Percentage (%)	73
Phone Line Voltage (V)	1.4

The 'Tests' section on the right contains several 'Test' buttons for 'Phone Line', 'Cellular Modem', 'Create Test Alarm', 'Send Email', and 'Send Push Notification'.

Figure 14: Home Screen – Power Management

2. Disconnect the power. Upon disconnecting the power:

- The Charge Currency drops to zero (0).
- Battery Voltage and Battery Percentage (refer to Figure 15):
  - In fresh batteries, these numbers remain stable over a long period of time.
  - In older batteries, these numbers drop rapidly.

**NOTE:** While Figure 15 shows an example test that lasts 45 minutes, there is no need to test your unit for that long. A five-minute test is sufficient.

**NOTE:** The Communicator 2.0 Plus can operate using the battery for an extended period. If the screen goes black immediately, replace the battery.

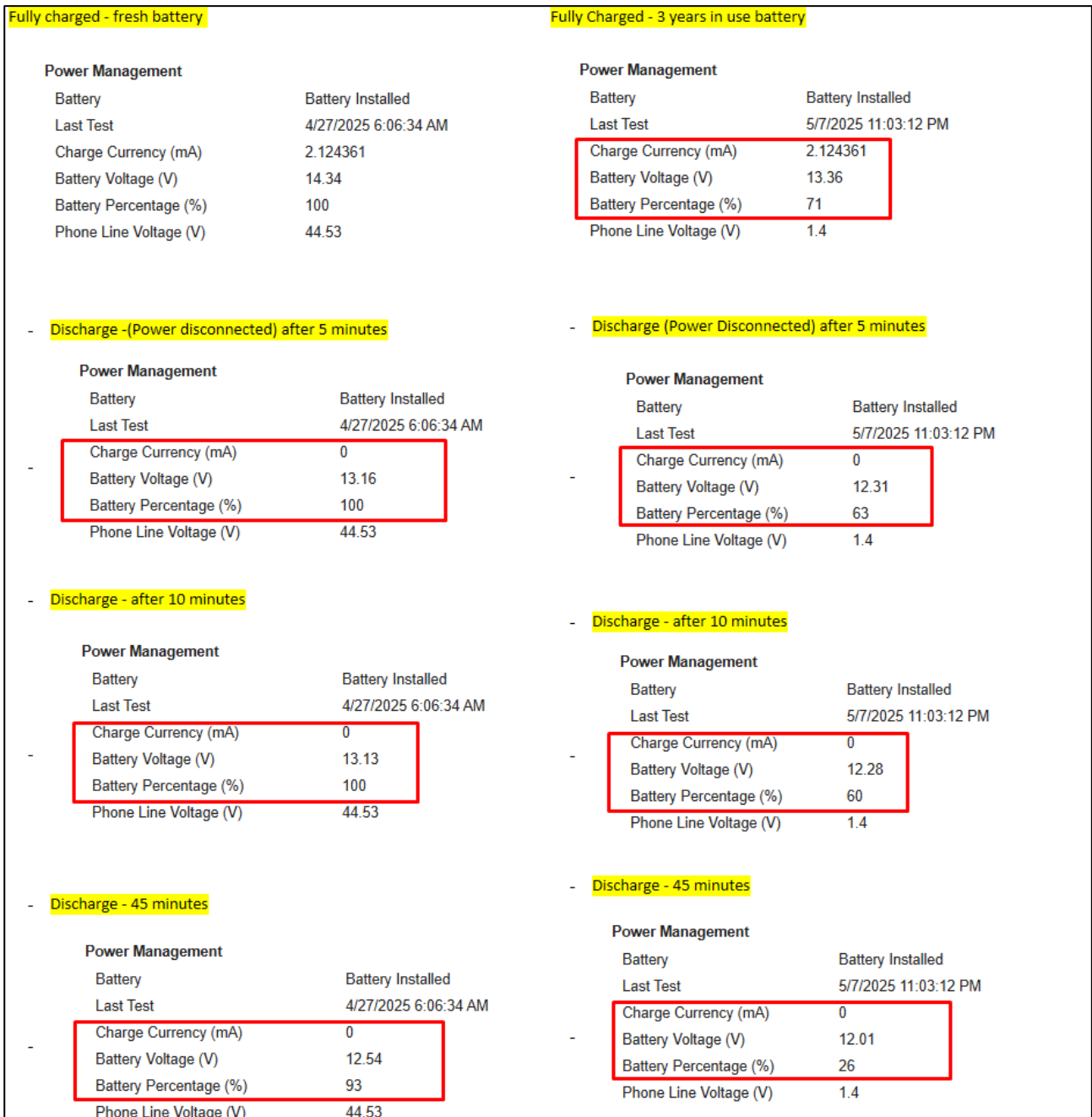

Figure 15: Power Management Specification in Fresh and Old Batteries

3. Reapply power. Upon connecting the power:

- The Charge Current jumps to 250 mA (approximately).
- Battery Voltage and Battery Percentage (refer to Figure 15):
  - In fresh batteries, these numbers return to their previous levels.
  - In older batteries, the Battery Percentage remains well below 100%

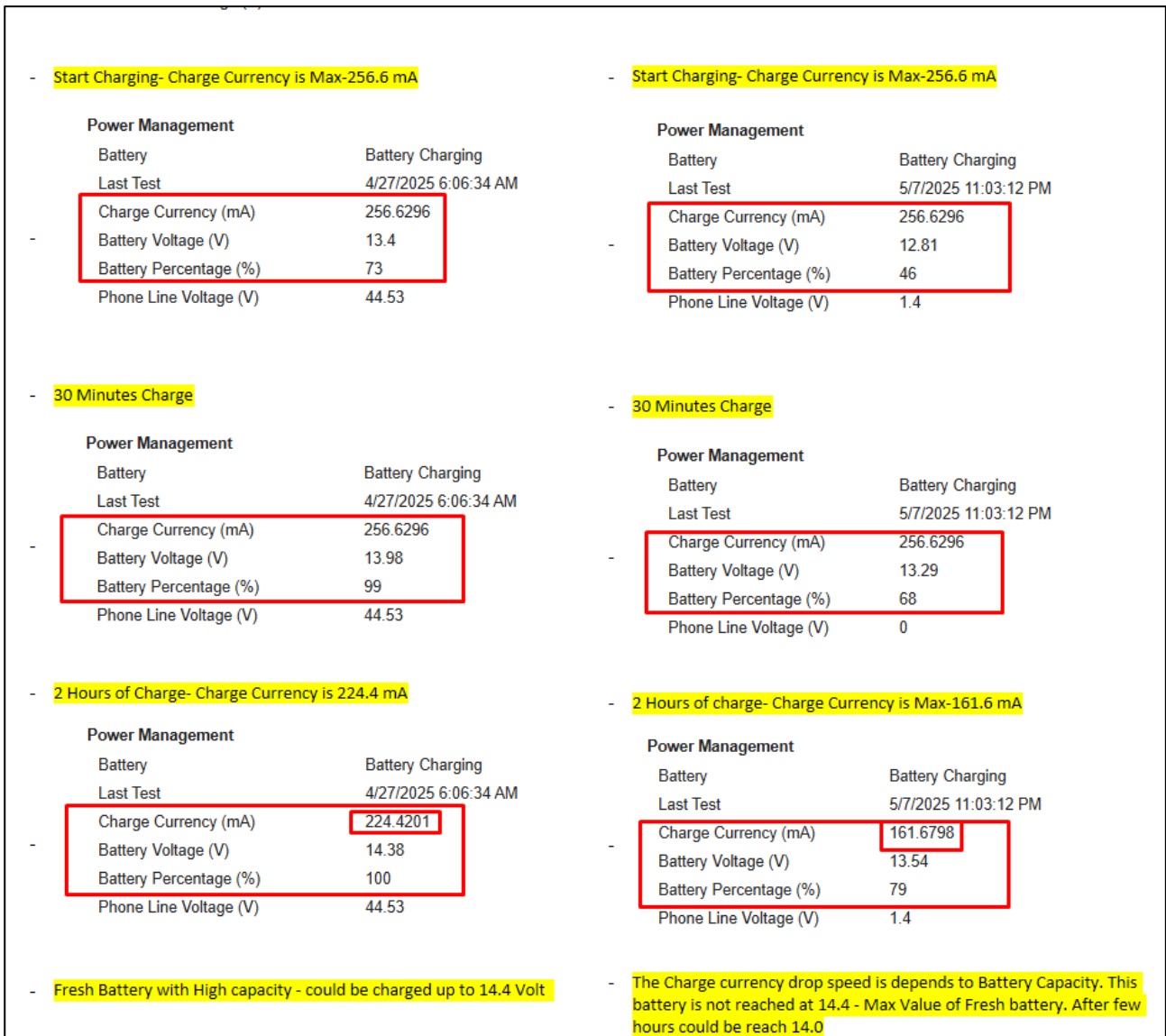





Figure 16: Power Management Recharge in Fresh and Old Batteries

- Conclusion: Based on the above procedure:
  - The lower the Battery Percentage, the greater the need to replace the battery.
  - If the Battery Voltage drops below 12V, the battery should be replaced.

# 4 Specifications

Power Supply	
Mains Input Power	100 - 240 VAC, 50/60 Hz
Maximum Power Consumption	1.8A
Main Fuses	
Main Fuse 230/115 VAC	F1: 250 VAC/3 A
Battery Fuse	F2: 1.85 A
Switching Power Supply	F3: 1.1 A
Connection Box Peripherals	
8 Digital Inputs	Dry Contact, 5V / 2 mA
Relays Outputs	
N.C/N.O. (OMI) Blue Small Low Power Relay	5 Amps, 250 VAC
Alarm Output	
N.O and N.C (Double) (OMI) Pilot Duty	5 Amps, 250 VAC
Environmental Specifications	
<ul style="list-style-type: none"> <li>• Indoor use only</li> <li>• Altitude: -400 m to 2000 m</li> <li>• Relative Humidity: 20% - 70%</li> <li>• Main supply voltage fluctuation up to 5%</li> <li>• Overvoltage category II</li> </ul>	
Housing	
Metal Box Dimensions (L x W x H)	416 x 266 x 60 mm
Ambient Climate	
Operating Temperature Range	0° to +35° C / +32° to +95° F
Storage Temperature Range	-10° to +50° C / +14° to +125° F
Certification	
   	

# 5 Functionality

The following sections describe how to use the web functions.

- Farm Settings
- Alarms
- Responding to Alarms
- Testing the Communicator 2.0
- Additional Functions

## 5.1 Farm Settings

Use this screen to define functions related to Communicator 2.0's connection to your farm.

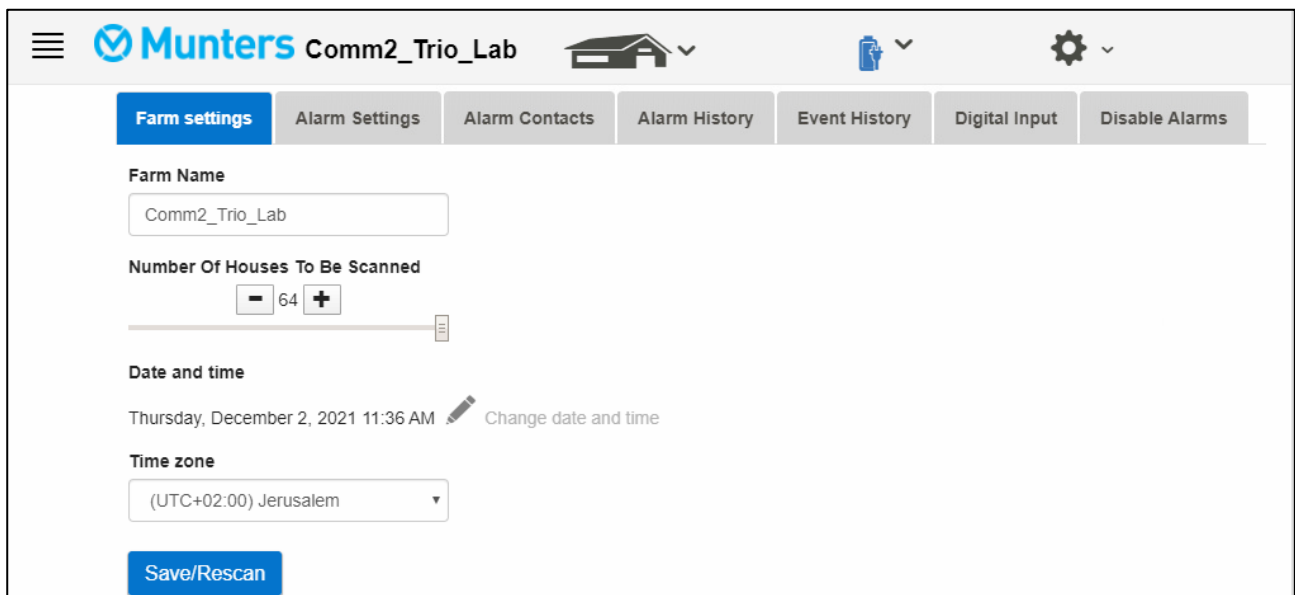

The screenshot shows the Munters web interface for the 'Comm2\_Trio\_Lab' farm. The top navigation bar includes the Munters logo, the farm name, and several icons: a house, a battery, and a gear. Below the navigation bar is a menu with tabs: 'Farm settings' (highlighted in blue), 'Alarm Settings', 'Alarm Contacts', 'Alarm History', 'Event History', 'Digital Input', and 'Disable Alarms'. The 'Farm settings' section contains the following fields:

- Farm Name:** A text input field containing 'Comm2\_Trio\_Lab'.
- Number Of Houses To Be Scanned:** A slider control with minus and plus buttons, currently set to 64.
- Date and time:** A text field showing 'Thursday, December 2, 2021 11:36 AM' with a pencil icon and a 'Change date and time' link.
- Time zone:** A dropdown menu showing '(UTC+02:00) Jerusalem'.

At the bottom of the form is a blue 'Save/Rescan' button.

- **Farm Name:** This name appears on your screen.
- **Number of Trios to be Scanned:** Click the -/+ buttons to enter the number of houses. Scanning tests communication to the Trios. If you wish to scan all houses or individual houses, click the relevant house number. Click Rescan farm houses to complete the scan.

**NOTE** The number of units entered must match the actual number of units. If they differ, an error message appears. Up to 64 houses can be scanned.

- **Date and Time/Time Zone:** Enter the information.
- Click **Save Changes**.

## 5.2 Alarms

This section describes how to configure the alarms. All other functions are described in the Platinum Touch manual.

- Alarms can only be configured locally. Anyone viewing the Communicator 2.0 screen via the web will not see Alarm System in the Settings icon.
  - The alarm settings defined in these screens are general definitions that apply to all alarms unless the alarm has a specific parameter that defines the setting. In that case, the alarm parameter will override the alarm setting defined here.
  - **Extremely important:** Set up a [contact list](#) after installing the unit. You must enter the 1st contact's name and email address in order to activate Communicator 2.0.0's alarm functionality! This contact, once entered, cannot be deleted, only edited.
- 
- Editing the Settings
  - Adding Contacts
  - Alarm and Events History
  - Digital Inputs
  - Disable Alarms
  - Clear Alarms

## 5.2.1 EDITING THE SETTINGS

1. Click the Alarm Settings tab.

The screenshot shows the Munters field test YM interface with the Alarm Settings tab selected. The interface is divided into three main sections: Alarm Settings, About, and Tests. The Alarm Settings section includes fields for Alarm Report Delay (10 sec), User Gap Time (10 sec), Message Repeat Delay (15 min), Test Message Time (9:00), Country of installation (Italy), Generator IP Address, Phone Line Alarm (Off), Line-Out Volume (10), and Voice Speech Speed (5). The About section includes Connectivity (Baud Rate 9600, Com Port COM4), Cellular Signal (IMEI 862771042599756), Power Management (Battery Installed 10/6/2024 8:44:56 PM, Charge Currency 2.124361 mA, Battery Voltage 13.15 V), Network Properties (Serial ID TSBG00423053), and Hardware Profile (Email 1.00.08.00, Push 1.00.08.01, Notification 1.01.08.07, Sms 1.01.08.25, WDT 1.01.08.07, Parser 1.00.08.19, Gateway V1\_70, Power 1.0B.00.00, Board Communicator- 1.1.9.13, 2). The Tests section includes buttons for Phone Line, Cellular Modem, Create Test Alarm, Send Email, Send Push Notification, and Clear Houses & Alarms.

The screen displays the current alarm settings along with Communicator 2.0 parameter settings. In addition the screen displays:

- Phone line specifications
- Power board firmware version

2. To edit the Alarm Settings click .

The screenshot displays the Munters Comm2\_Trio\_Lab web interface. At the top, there is a navigation bar with the Munters logo, the title 'Comm2\_Trio\_Lab', and several icons including a house, a phone, and a gear. Below the navigation bar are tabs for 'Farm settings', 'Alarm Settings' (which is active), 'Alarm Contacts', 'Alarm History', 'Event History', 'Digital Input', and 'Disable Alarms'.

The main content area is divided into three columns:

- Alarm Settings:** Contains several adjustable parameters:
  - Alarm Report Delay:** A text input field with '60' and 'sec.' next to it. Below it, a description: 'Minimum time that an alarm event continues before sending a report'.
  - User Gap Time:** A text input field with '2' and 'sec.' next to it. Below it, a description: 'Time delay before a message is sent to next user in the list'.
  - Message Repeat Delay:** A text input field with '60' and 'min.' next to it. Below it, a description: 'If no alarm acknowledgement is sent - define time before message transmission restarts'.
  - Test Message Time:** A dropdown menu showing '9:00'. Below it, a description: 'Scheduled daily test'.
  - Country of installation:** A dropdown menu showing 'Germany'.
  - Generator Ip Address:** An empty text input field.
  - Phone Line Alarm:** A toggle switch currently set to 'Off'. Below it, a description: 'Send an alarm if telephone line is disconnected'.
  - Line-Out Volume:** A volume icon and a slider set to '10'. Below it, a description: 'Define the volume during a phone call'.
- About:** Contains system information:
  - Connectivity:** Baud Rate (9600), Com Port (COM4).
  - Cellular Signal:** No Signal, IMEI (867962041263990).
  - Power Management:** Battery (Battery Installed), Last Test (11/23/2021 5:40:51 PM).
  - Serial ID:** TRIO15092020.
  - Hardware Profile:** A list of components and their versions: Email (1.00.08.00), Push (1.00.08.01), Notification, Sms (1.01.08.21), WDT (1.01.08.06), Parser (1.00.08.20), Gateway (V1\_70), Power (1.0B.00.00), Board, Communicator- (1.1.8.84), and 2.
- Tests:** Contains several test buttons:
  - Phone Line:** Test >
  - Cellular Modem:** Test >
  - Create Test Alarm:** Test >
  - Send Email:** Test >
  - Send Push Notification:** Test >
  - Factory Defaults:** Clear Houses & Alarms (Clear >)

### 3. Edit the following parameters:

- **Alarm Report Delay:** To prevent you from being overloaded with insignificant alarms, you can define the amount of time an alarm condition must continue before an alarm is sent.
- **User Gap Time:** Define the delay time (if any) between messages sent to the next person on the list (see the Priority setting).
- **Message Repeat Delay:** Alarms must be acknowledged or messages are resent to the list. Define the amount of time in which acknowledgment must take place before resending messages.
- **Test Message Time:** A test message can be sent daily to ensure that message transmission is operating properly. This parameter sets the time that this message is sent.

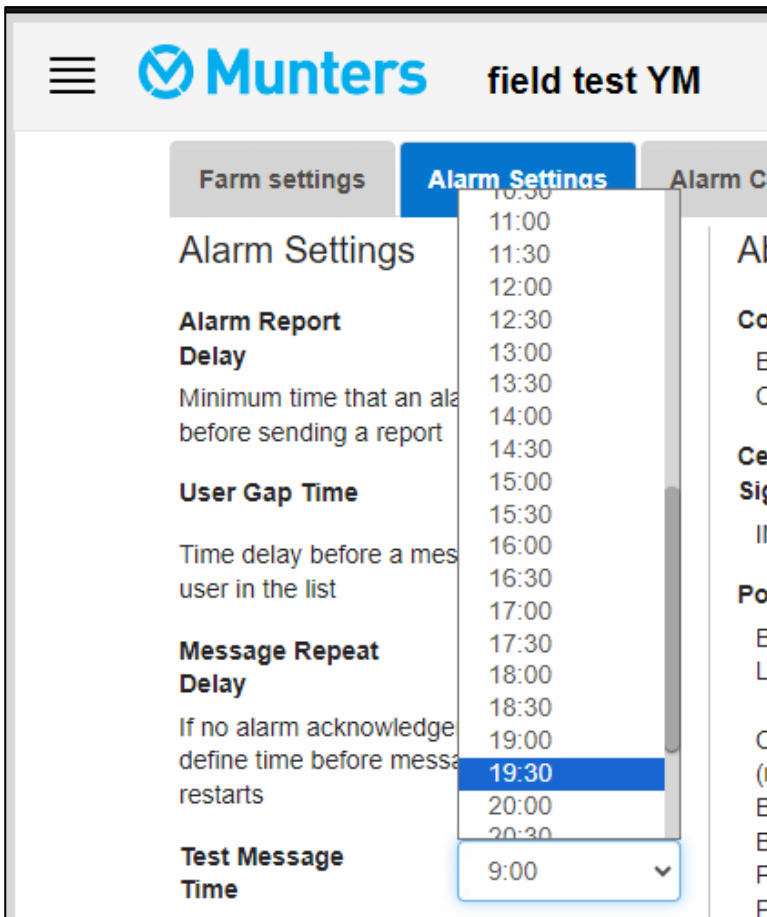

- Country of installation: Choose from the drop down list.
- Generator Ip Address (US customers only): Users having a backup generator connected to the Communicator 2.0 can enter the generator’s IP address. Communicator 2.0 will transmit any alarms from the generator.
- Phone Line alarm: Enable sending an alarm if the phone line is disconnected.
- Line-Out Volume: Define the call volume.

**NOTE:** *The above two parameters require telephony connectivity to be enabled.*

- Voice Speech Speed: Define the text-to-speech playback speed.
- About: These read-only parameters provide data for service technicians.

4. Click Save.

### 5.2.2 ADDING CONTACTS

1. Click the Alarm Contacts tab.
2. Click . The following screen appears.

### 3. Fill in:

- Contact name

**WARNING!** There must be at least one contact name or the alarms will not function!

- Priority: If there is more than one contact, you can define the order in which the contacts receive messages.
- Voice Message Number/Text Message Number:
  - Add a number for an outside line if required.
  - Enter the exit code/country code/area code (if required) and the numbers. Enter numbers only; do not enter dashes, spaces, or any other character (including a plus (+) sign). For example, if the controller is in the US and the contact is in:
    - Harrisburg, Pennsylvania, dial: #1717XXXXXXX
    - London, England, dial: #0114420XXXXXXX
    - # is the outside line number (if required)
- Email address

**NOTE:** To receive push notifications, use the email address used to activate each account. You can enter any email address but only the activation address enables push notifications.

- Message Type: Mark the checkbox(es) next to message type(s) that this contact is to receive.
  - Email
  - Push notifications
- Language: Select the language from the drop down list.
- Availability:
  - Select the days on which messages are sent to the contact.
  - Define the hours in which messages are sent to the contact.

- **Permission:**
  - Allow User to Reset Alarm: Select On/Off.
  - Pin code for incoming calls (optional): The Pin code provides a second level of security to the alarm system. The first level of security is the contact list; only these numbers can interact with the Communicator 2.0. If a pin code is added, only someone having the code can reset the alarms, even when calling from an authorized phone number.

4. Click Save .

5. Other functions

- **Active/Disabled:** If you want to stop sending messages to a contact but do not want to delete the contact, select Disabled.
- **Delete a contact:** Click .

**NOTE:** Click on an existing contact name to edit the person's settings

### 5.2.3 ALARM AND EVENTS HISTORY

- Click Alarms History to view a view a list of alarms and information about each alarm.
- Click Events History to view a list of events connected to the Communicator 2.0.

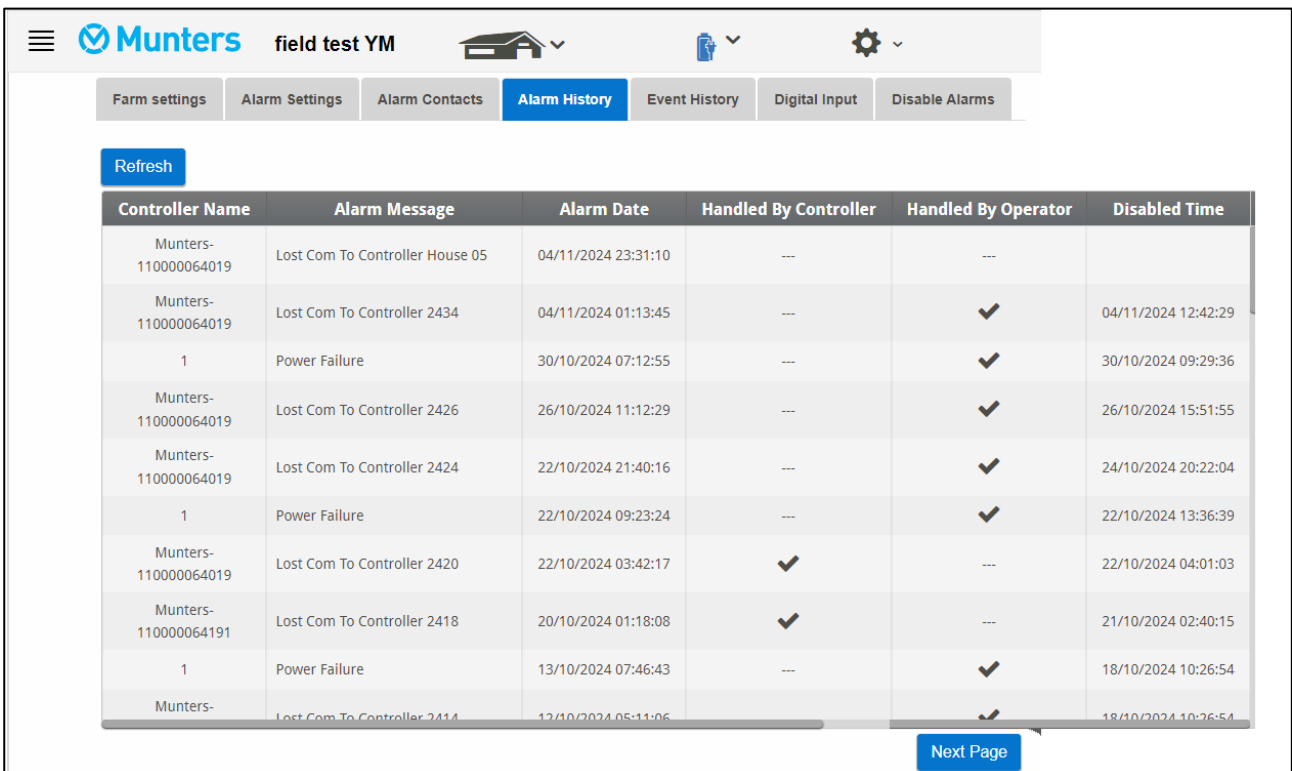

Controller Name	Alarm Message	Alarm Date	Handled By Controller	Handled By Operator	Disabled Time
Munters-11000064019	Lost Com To Controller House 05	04/11/2024 23:31:10	---	---	
Munters-11000064019	Lost Com To Controller 2434	04/11/2024 01:13:45	---	✓	04/11/2024 12:42:29
1	Power Failure	30/10/2024 07:12:55	---	✓	30/10/2024 09:29:36
Munters-11000064019	Lost Com To Controller 2426	26/10/2024 11:12:29	---	✓	26/10/2024 15:51:55
Munters-11000064019	Lost Com To Controller 2424	22/10/2024 21:40:16	---	✓	24/10/2024 20:22:04
1	Power Failure	22/10/2024 09:23:24	---	✓	22/10/2024 13:36:39
Munters-11000064019	Lost Com To Controller 2420	22/10/2024 03:42:17	✓	---	22/10/2024 04:01:03
Munters-11000064191	Lost Com To Controller 2418	20/10/2024 01:18:08	✓	---	21/10/2024 02:40:15
1	Power Failure	13/10/2024 07:46:43	---	✓	18/10/2024 10:26:54
Munters-	Lost Com To Controller 2414	13/10/2024 05:11:06	---	✓	18/10/2024 10:26:54

## 5.2.4 DIGITAL INPUTS

Communicator 2.0 supports an eight dry contact digital input card (found in the External Box) that can be programmed as normally open / normally closed input. These inputs can be connected to a wide variety of sensors such as generator operation, magnetic door or window, thermostat, etc.

➔ Wire the devices to the external box.

1. Click the Digital Input tab.

DI Number	Text Message	Notification Delay (Sec.)	N...	A...	A...
1	Not Defined	10	<input type="checkbox"/>	<input type="checkbox"/>	<input type="checkbox"/>
2	Not Defined	10	<input type="checkbox"/>	<input type="checkbox"/>	<input type="checkbox"/>
3	Not Defined	10	<input type="checkbox"/>	<input type="checkbox"/>	<input type="checkbox"/>
4	Not Defined	10	<input type="checkbox"/>	<input type="checkbox"/>	<input type="checkbox"/>
5	Not Defined	10	<input type="checkbox"/>	<input type="checkbox"/>	<input type="checkbox"/>
6	Not Defined	10	<input type="checkbox"/>	<input type="checkbox"/>	<input type="checkbox"/>
7	Not Defined	10	<input type="checkbox"/>	<input type="checkbox"/>	<input type="checkbox"/>
8	Not Defined	10	<input type="checkbox"/>	<input type="checkbox"/>	<input type="checkbox"/>

Save Changes

2. Fill in the following fields:

- Text message: Enter the text to be sent to the contact(s).
- Notification delay: Minimum time required to pass before a message is sent.
- NC/NO: Checking this box means that the contact is Normally Closed.
  - NC means “Normally Closed”. If there is a change from the usual state (device opens), an alarm occurs.
  - NO means normally open. If there is a change from the usual state (device closes), an alarm occurs.
- Allow to Reset:
  - When this function is not checked, Communicator 2.0 sends a message to every contact (in the order given in the priority list) when an alarm is generated.
  - When checked, Communicator 2.0 sends a message to the first person in the priority list. If that person acknowledges the message, no further messages are sent. If the person does not acknowledge the message, Communicator 2.0 repeats the process and sends a message to the second person on the list.
- Active: When checked the alarm function for that digital input is enabled.

## 5.2.5 DISABLE ALARMS

To disable an alarm:

1. Click the **Disable Alarms** tab.
2. Click the corresponding radio box.

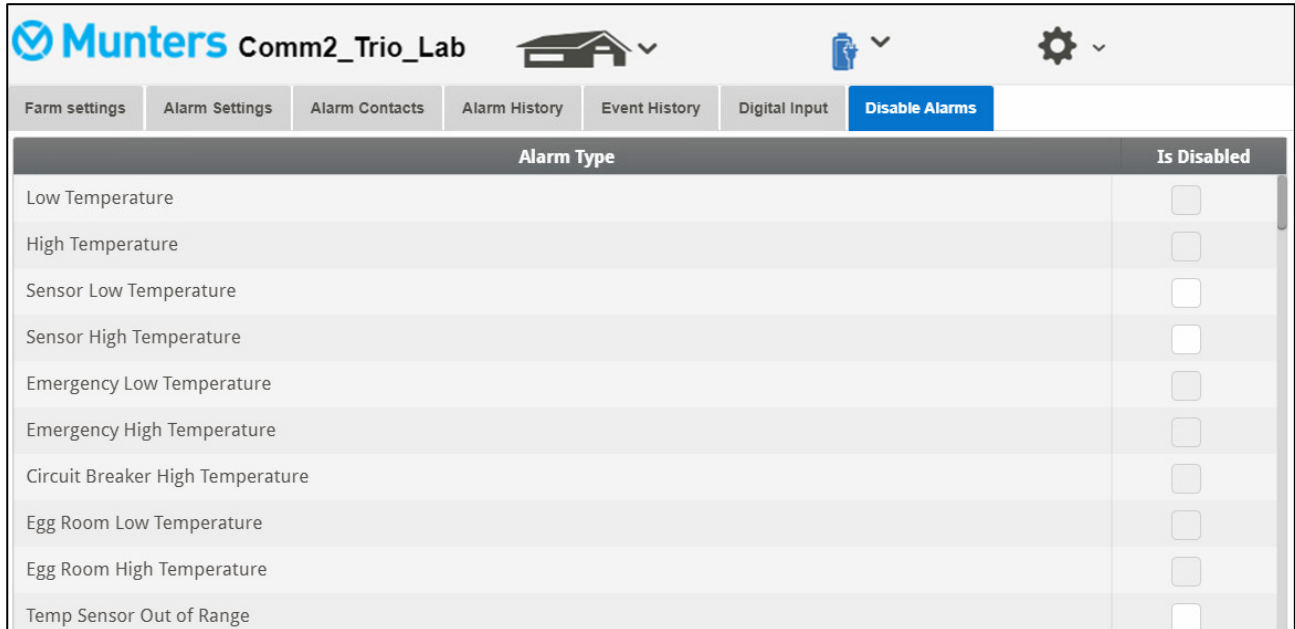

Alarm Type	Is Disabled
Low Temperature	<input type="checkbox"/>
High Temperature	<input type="checkbox"/>
Sensor Low Temperature	<input type="checkbox"/>
Sensor High Temperature	<input type="checkbox"/>
Emergency Low Temperature	<input type="checkbox"/>
Emergency High Temperature	<input type="checkbox"/>
Circuit Breaker High Temperature	<input type="checkbox"/>
Egg Room Low Temperature	<input type="checkbox"/>
Egg Room High Temperature	<input type="checkbox"/>
Temp Sensor Out of Range	<input type="checkbox"/>

**NOTE** All alarms are listed. However, there are alarms which cannot be disabled due to their importance.

## 5.2.6 CLEAR ALARMS

To clear the alarm history, under Factory Defaults, click **Clear**.

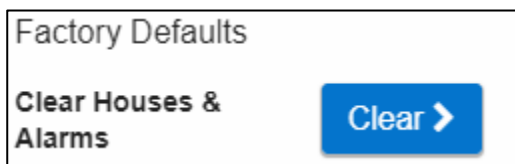

## 5.3 Responding to Alarms

Upon receiving an alarm message (voice or SMS), you can respond to the message. The following sections detail how to respond to these messages.

- Responding to an Audio Message
- Responding to a Text Message

### 5.3.1 RESPONDING TO AN AUDIO MESSAGE

Communicator 2.0 sends voice messages to the designated people on the contact list. This section details the procedure to follow when an audio alarm is received.

**NOTE:** *This service is provided by the Communicator 2.0 ONLY if the contact is properly defined with contacts and the "VOICE" service selected per contact.*

Communicator only broadcasts its alarm message **AFTER** someone speaks into the phone. Any word or sound is sufficient.

- Receiving the Message
- Responding to the Alarm Message

### 5.3.1.1 Receiving the Message

The following illustrates the sequence of ALARM messages:

"Good <Morning / Afternoon / Evening> farm <#> active alarm.  
Please, press 1 to listen."



"House <#> has <#> alarm message<s>."

- Alarm messages for the first house are played and then the following options are available:

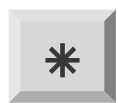

Acknowledge



Replay house message



Play next house message



End call



- Enter password (if acknowledging for the first time this call) and press \*.
- "Please wait... Reset for house <#> successful. <Next Message / Goodbye>."
- When you hear "Please wait" press \* to access the ALARM OPTIONS MENU.

### 5.3.1.2 Responding to the Alarm Message

- System reports alarm and then offers the following options:



Disable alarms

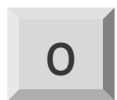

Return to house messages



Replay alarm message



End call

**NOTE:** *Disabling alarms disables them until 12:00 PM the following day.*

- "Disable <confirmed / failed>!" message is repeated and returns to House Alarm Messages

**NOTE:** *If at any time an incorrect key is pressed or if nothing is pressed, the system repeats itself three times and then ends the call.*

## 5.3.2 RESPONDING TO A TEXT MESSAGE

This section details how to respond to a text message sent from Communicator 2.0 to a mobile phone. The response can reset a siren, an alarm, or acknowledge the messages.

- Resetting the Siren
- Resetting the Alarm
- Acknowledging a Message

### 5.3.2.1 Resetting the Siren

**NOTE:** After typing the text message, press the 'Send' button to send it to the Communicator 2.0.

In the procedures below, the **highlighted text** shows the SMS text to be sent.

- **Resetting the Siren of One House**

**!RX** > 'Send SMS' to the Communicator 2.0 cell phone number.

! = Start of message

R = Reset

X = Represents house number (can be any positive number from 1-64)

- **Resetting the Siren of Several Houses**

**!RX#X#X** > 'Send SMS' to the Communicator 2.0 cell phone number

! = Start of message

R = Reset

X = Represents house number (can be any positive number from 1-64)

# = Sign separates between every house number

- **Resetting the Siren for All Houses**

**!RALL** > 'Send' to the Communicator 2.0 cell phone number

! = Start of message

R = Reset

ALL = Can be typed both in capital letters or small letters.

### 5.3.2.2 Resetting the Alarm

To reset all the alarms, send the following text message:

**!C** > 'Send' to the Communicator 2.0 cell phone number

! = Start of message

C = Communicator

### 5.3.2.3 Acknowledging a Message

Communicator 2.0 continues to send alarms until an acknowledgement is sent.

- **Requesting a Response for Every Sent Text Message**

**!AON** > 'Send' to the Communicator cell phone number

! = Start of message

A = Acknowledgement

- Canceling a Response for Every Sent Text Message  
 'Send' to the Communicator cell phone number  
 ! = Start of message  
 A = Acknowledgement

## 5.4 Testing the Communicator 2.0

- To test a communication function, on the Alarm Settings screen click:
  - Phone Line Test
  - Cellular Modem Test
  - Create Test Alarm
  - Send Email
  - Send Push Notifications

## 5.5 Additional Functions

- Software Upgrade
- Battery Status
- Controllers Connectivity
- About Tab / Technical Support

### 5.5.1 SOFTWARE UPGRADE

You can upgrade certain software programs from the Web application.

- Trio software
- Web application
- Communicator 2.0 software

**NOTE:** *The Communicator 2.0 can only be updated locally; it cannot be updated remotely. The System Update button does not appear in remote connections.*

**NOTE:** *You cannot upgrade product software! Upgrade your product software using the procedures given in the product manuals.*

**NOTE:** *If you are using a disk on key start here. If you are updating your Communicator 2.0 via the web, go to step 2.*

1. Request the software upgrade from your dealer. You will be sent (via email, web transfer, etc.) a UPD file.

a. Place the file on a disk on key/flash drive.

b. Place the disk on key/flash drive into the Communicator 2.0's USB port.

2. On the main screen, click the settings icon . From the drop down list select Software Update. The following screen appears:

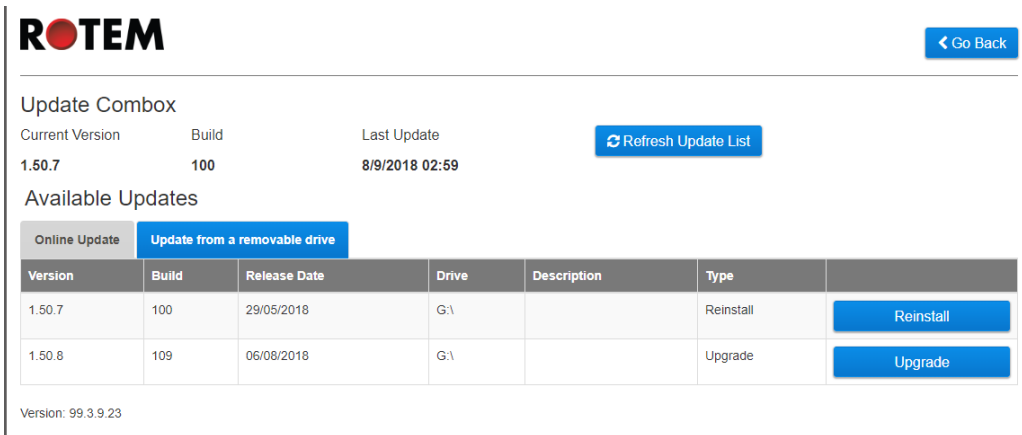

- Users updating online: Click Online Update and choose the required software version.
- User updating using a flash drive: Click Update from a removable drive and choose the required software version.

**NOTE:** *If you did not place the disk on key in the USB port or if the disk does not contain a program, an error message appears.*

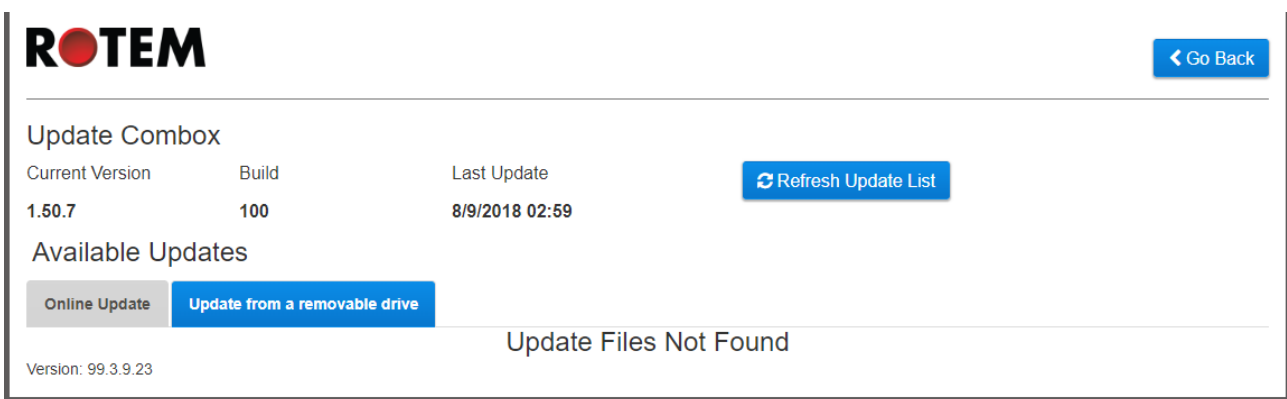

## 5.5.2 BATTERY STATUS



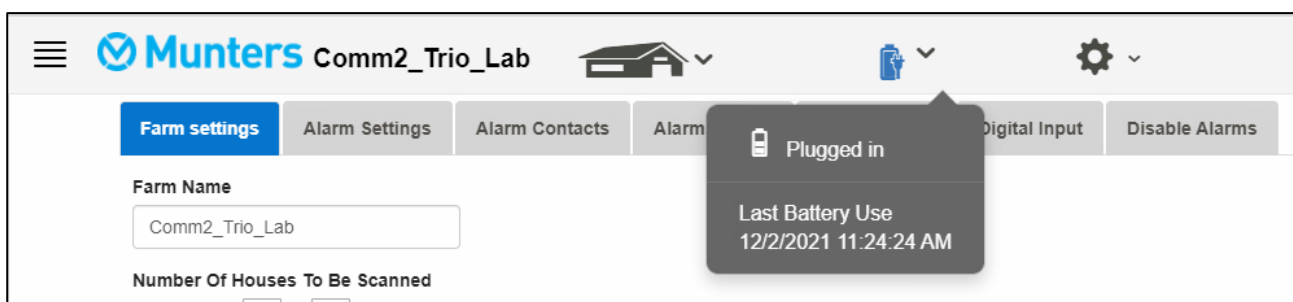





- Click on the battery symbol  to view the Communicator 2.0's battery status.



**NOTE:** *An alarm is sent when the Battery switch is turned off.*

### 5.5.3 CONTROLLERS CONNECTIVITY

Click on the house symbol  to view the status of the controller connectivity.

No.	Name	IP	
1	Room_1	10.16.8.111	
2	UnKnownRoom_255	10.16.8.114	
3	Room_1 & Room_2	10.16.8.119	
4	UnKnownRoom_25	10.16.8.100	
5	Room_1	10.16.8.135	
6	UnKnownRoom_1	10.16.8.122	
7	UnKnownRoom_1	10.16.8.107	
8	Room_1 & Room_2	10.16.8.115	



- Click on a specific house or room to go to that Trio unit.
- If a house has alarms, the house is red.

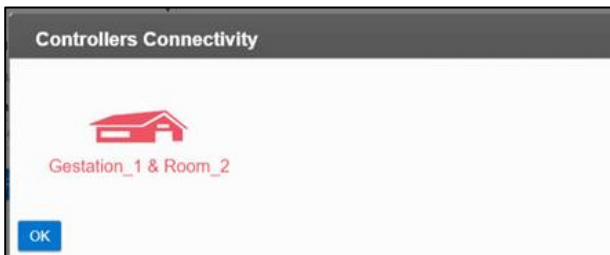

## 5.5.4 ABOUT TAB / TECHNICAL SUPPORT

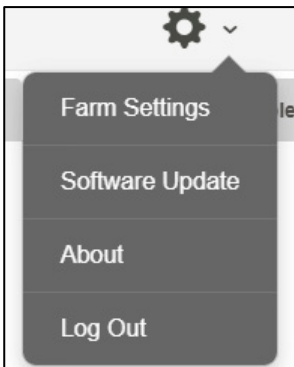



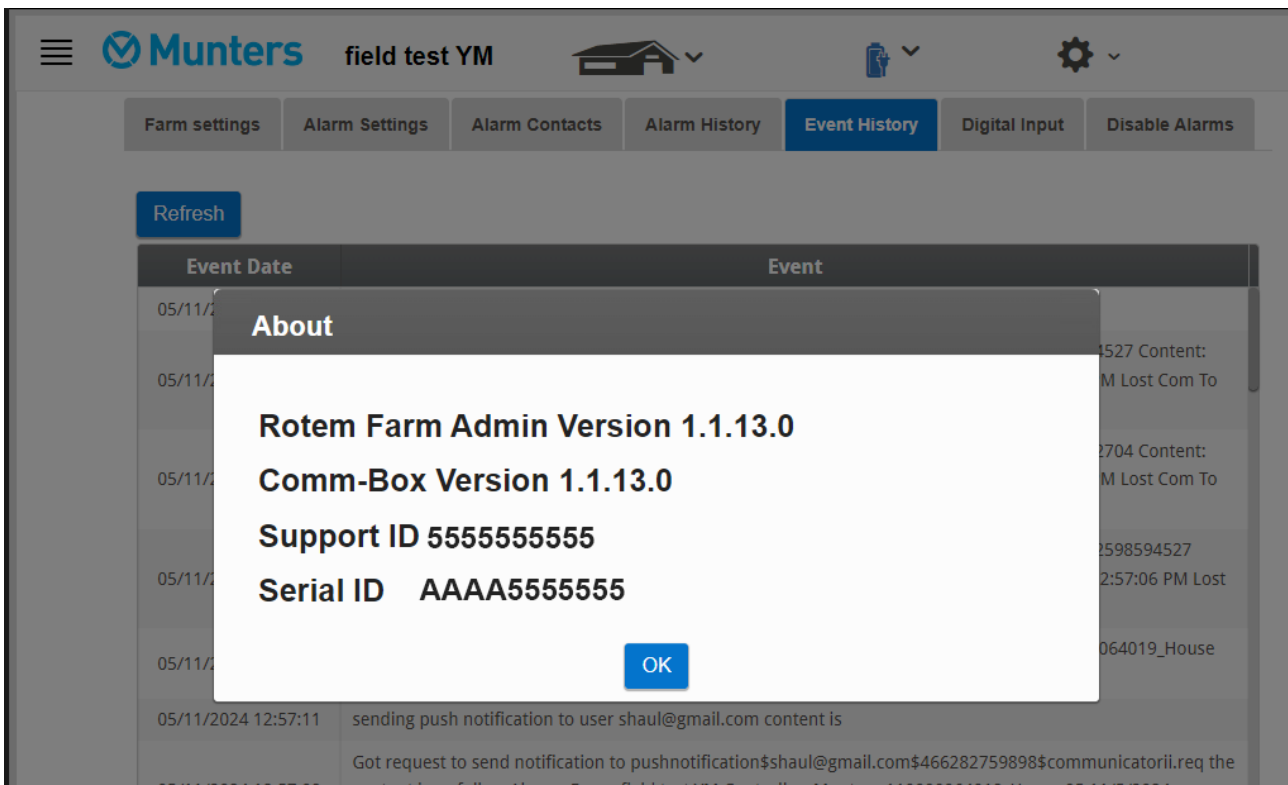





In the Settings icon, click **About** to display the product and software version. Send this information to technical support in the event that you require assistance. The Support ID enables remote technical support from Munters or from your dealer.



# 6 Diagnostics

Use the product LEDs to troubleshoot any issue.

LED	Description	Diagnosis
	Power LED. Power is applied.	Should be green
	Connectivity to RLINK One	<ul style="list-style-type: none"> <li>No light: No modem installed</li> <li>Red: Modem installed but no connectivity</li> <li>Green LED: OK</li> </ul>
	LAN signal	<ul style="list-style-type: none"> <li>No light: No modem installed</li> <li>Red: Modem installed but no connectivity to house</li> <li>Green Blinking LED: OK</li> </ul>
	Cell phone modem	<ul style="list-style-type: none"> <li>No light: No modem installed</li> <li>Red: Modem installed but no connectivity</li> <li>Green: OK</li> </ul>
	Telephone line	<ul style="list-style-type: none"> <li>No light: No modem installed</li> <li>Red: Modem installed but no connectivity</li> <li>Green: OK</li> </ul>
	Web connectivity: Tests connection to the application.	<ul style="list-style-type: none"> <li>No light: No physical connection</li> <li>Red: No connectivity</li> <li>Green: OK</li> </ul>
	Active alarm	<ul style="list-style-type: none"> <li>Off: No active alarm(s)</li> <li>On: Active alarm</li> </ul>
	Battery	<ul style="list-style-type: none"> <li>Red: Battery is disconnected</li> <li>Red Blinking: Battery is not charging (consult with dealer immediately)</li> <li>Green Blinking LED: Battery is charging</li> <li>Green: Battery is charged</li> </ul>

# 7 Appendix A: Changing the Battery

Munters recommends installing a new battery every two years.

- Change the battery between flocks or herds.
- Order a new battery from your dealer.

To replace the battery:

1. Disconnect the AC power.
2. On the rear panel, switch the battery to Off.

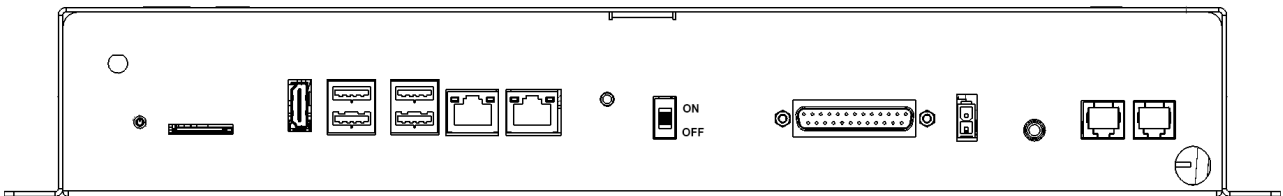

3. Disconnect all cables connected to the Communicator 2.
4. If the unit is mounted on a wall, take it down and place it on a table.
5. Remove the six screws indicated and lift the Communicator 2's top.

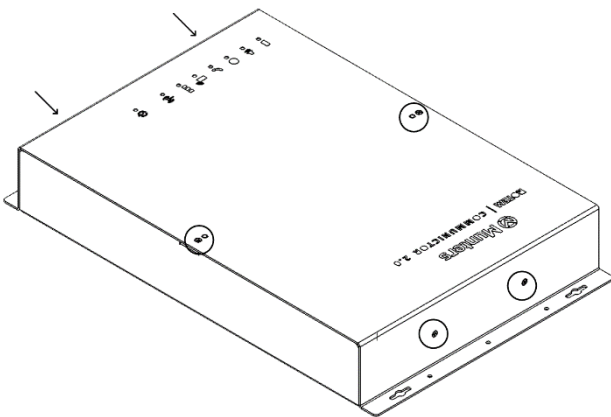

6. Using a box spanner, remove the four screws indicated (and their clamps).

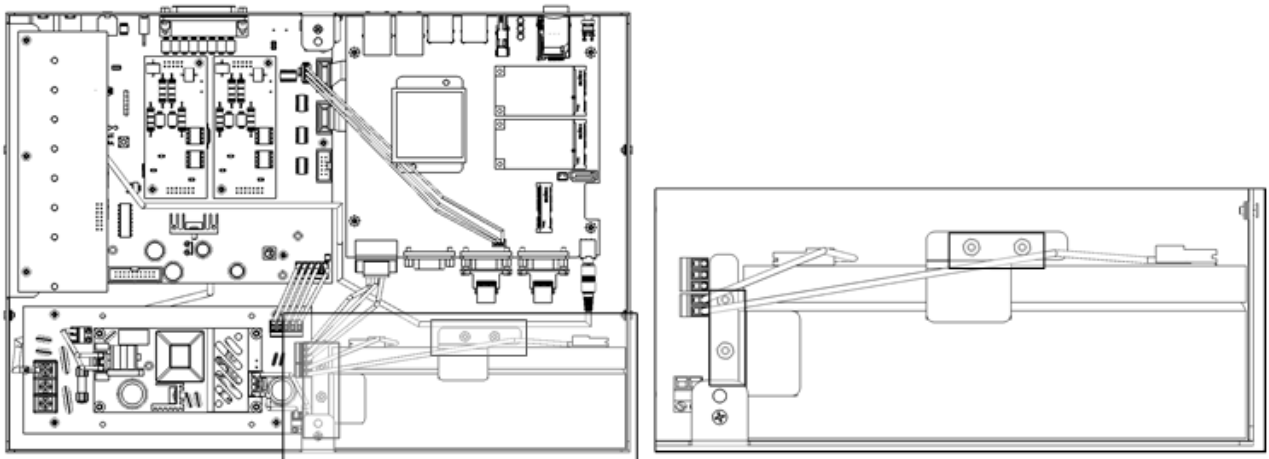

7. Remove the red and black cables from the battery (in this order).



8. Remove the battery and put the new battery in place.

9. Reconnect the cables.

10. Secure the battery in place.

11. Place the cover in place and insert the screws.

12. Place the unit on the wall (optional) and reconnect the cables.

13. Turn on the battery switch, apply AC power, and verify that the Power LED is lit.

# 8 Warranty

## Warranty and technical assistance

Munters products are designed and built to provide reliable and satisfactory performance but cannot be guaranteed free of faults; although they are reliable products they can develop unforeseeable defects and the user must take this into account and arrange adequate emergency or alarm systems if failure to operate could cause damage to the articles for which the Munters plant was required: if this is not done, the user is fully responsible for the damage which they could suffer.

Munters extends this limited warranty to the first purchaser and guarantees its products to be free from defects originating in manufacture or materials for one year from the date of delivery, provided that suitable transport, storage, installation and maintenance terms are complied with. The warranty does not apply if the products have been repaired without express authorisation from Munters, or repaired in such a way that, in Munters' judgement, their performance and reliability have been impaired, or incorrectly installed, or subjected to improper use. The user accepts total responsibility for incorrect use of the products.

The warranty on products from outside suppliers fitted to Communicator 2.0, (for example antennas, power supplies, cables, etc.) is limited to the conditions stated by the supplier: all claims must be made in writing within eight days of the discovery of the defect and within 12 months of the delivery of the defective product. Munters has thirty days from the date of receipt in which to take action, and has the right to examine the product at the customer's premises or at its own plant (carriage cost to be borne by the customer).

Munters at its sole discretion has the option of replacing or repairing, free of charge, products which it considers defective, and will arrange for their despatch back to the customer carriage paid. In the case of faulty parts of small commercial value which are widely available (such as bolts, etc.) for urgent despatch, where the cost of carriage would exceed the value of the parts, Munters may authorise the customer exclusively to purchase the replacement parts locally; Munters will reimburse the value of the product at its cost price.

Munters will not be liable for costs incurred in demounting the defective part, or the time required to travel to site and the associated travel costs. No agent, employee or dealer is authorised to give any further guarantees or to accept any other liability on Munters' behalf in connection with other Munters products, except in writing with the signature of one of the Company's Managers.

**WARNING:** In the interests of improving the quality of its products and services, Munters reserves the right at any time and without prior notice to alter the specifications in this manual.

The liability of the manufacturer Munters ceases in the event of:

- dismantling the safety devices;
- use of unauthorised materials;
- inadequate maintenance;
- use of non-original spare parts and accessories.

Barring specific contractual terms, the following are directly at the user's expense:

- preparing installation sites;
- providing an electricity supply (including the protective equipotential bonding (PE) conductor, in accordance with CEI EN 60204-1, paragraph 8.2), for correctly connecting the equipment to the mains electricity supply;
- providing ancillary services appropriate to the requirements of the plant on the basis of the information supplied with regard to installation;
- tools and consumables required for fitting and installation;
- lubricants necessary for commissioning and maintenance.

It is mandatory to purchase and use only original spare parts or those recommended by the manufacturer.

Dismantling and assembly must be performed by qualified technicians and according to the manufacturer's instructions.

The use of non-original spare parts or incorrect assembly exonerates the manufacturer from all liability.

Requests for technical assistance and spare parts can be made directly to the nearest [Munters office](#).

